



Study on CNOSSOS-EU final report

Author: Olaf Uszynski, Carolin Schliephake

- » **Project plan**
- » **Work Package 1 → Literature review**
 - » WP 1.1: Analysis of current source description models (END & CNOSSOS-EU)
 - » WP 1.2: Evaluation of noise mapping & management actions
- » **Work Package 2 → Elaboration of correction factors**
 - » WP 2.1: Analysis of existing source description methods
 - » WP 2.2: Determination of source description accuracy
 - » WP 2.3: Suitable adaptations of the source description
- » **Summary**
- » **Outlook**

- » **Project plan**
- » **Work Package 1 → Literature review**
 - » WP 1.1: Analysis of current source description models (END & CNOSSOS-EU)
 - » WP 1.2: Evaluation of noise mapping & management actions
- » **Work Package 2 → Elaboration of correction factors**
 - » WP 2.1: Analysis of existing source description methods
 - » WP 2.2: Determination of source description accuracy
 - » WP 2.3: Suitable adaptations of the source description
- » **Summary**
- » **Outlook**

- » **Project plan**
- » **Work Package 1 → Literature review**
 - » WP 1.1: Analysis of current source description models (END & CNOSSOS-EU)
 - » WP 1.2: Evaluation of noise mapping & management actions
- » **Work Package 2 → Elaboration of correction factors**
 - » WP 2.1: Analysis of existing source description methods
 - » WP 2.2: Determination of source description accuracy
 - » WP 2.3: Suitable adaptations of the source description
- » **Summary**
- » **Outlook**

1. Elaboration of a high-level description of the CNOSSOS-EU model

- » Derivation of the relevant model parameters and data sets for further project WPs

2. Development of an overview on road traffic noise source description models

- » Determination of suitable models for comparison

3. Overview on underlying data of the CNOSSOS-EU model

- » **Environmental noise directive (END) 2002/49/EC**
 - » Strategic noise maps every 5 years since 2007, including roads traffic, railway, aircraft & industry
 - » The aim is to use a common model
 - » Outcome of 1st strategic noise maps: Significant deviation between models and no comparability given

- » **Consistent source description is needed**
 - » States have developed own models for noise mapping (and therefore source descriptions) in the past (see overview on **slide 16**)

- » **Goal: Common model for member states for noise mapping**

[ABB02] [ECO12] [EUR02] [ZHA14]

» CNOSSOS-EU: A method for calculating ambient noise with the goal of strategic noise mapping

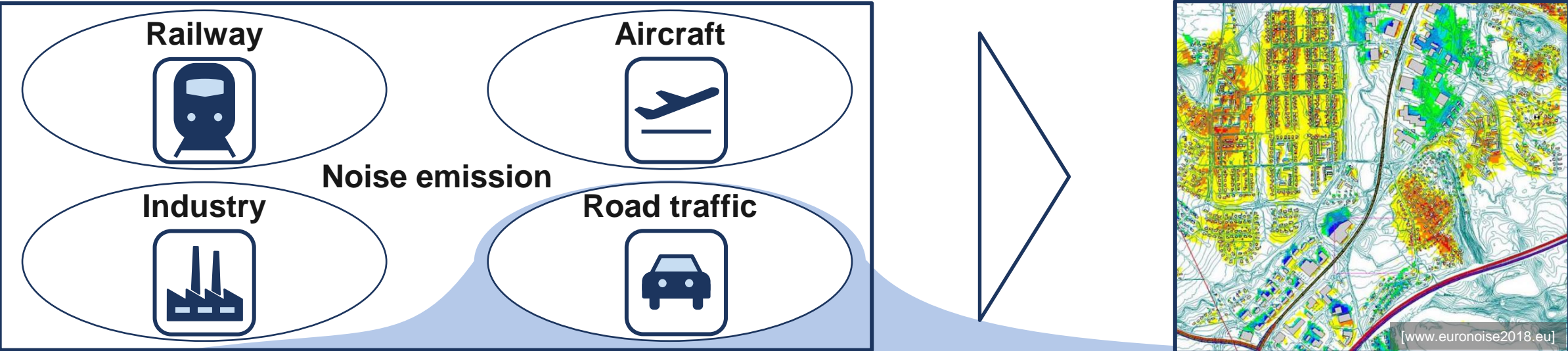

» **CNOSSOS-EU: A method for calculating ambient noise with the goal of strategic noise mapping**

Model

Different vehicle categories:

1. Light motor vehicles
2. Medium heavy vehicles
3. Heavy vehicles
4. Powered two-wheelers
5. Open category

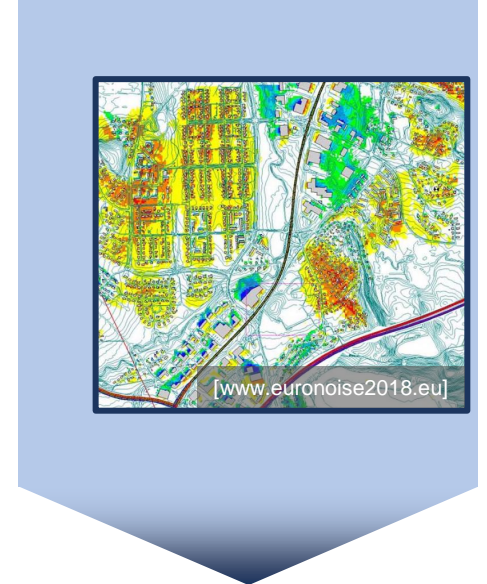
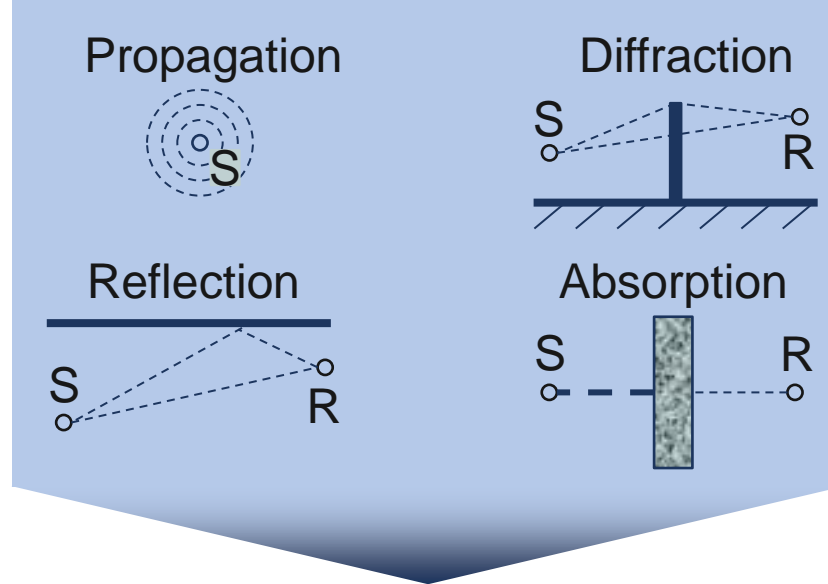
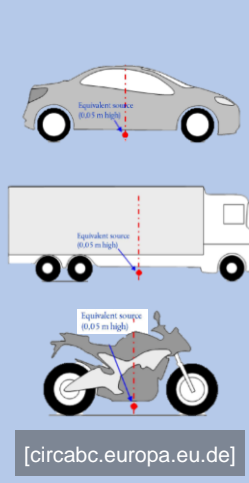

Reality



» CNOSSOS-EU: A method for calculating ambient noise with the goal of strategic noise mapping

Model

Different vehicle categories:

1. Light motor vehicles
2. Medium heavy vehicles
3. Heavy vehicles
4. Powered two-wheelers
5. Open category

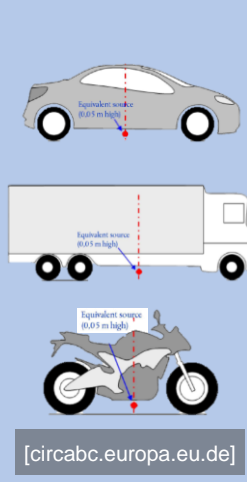

Reality

Source



CNOSSOS-EU vehicle sound source description [EUR15]

- » Source model is divided into
 - » Rolling noise
 - » Propulsion noise
- » Several correction factors (CFs), e.g. regarding intersections, road surface, ...

» **CNOSSOS-EU: A method for calculating ambient noise with the goal of strategic noise mapping**

Model

Different vehicle categories:

1. Light motor vehicles
2. Medium heavy vehicles
3. Heavy vehicles
4. Powered two-wheelers
5. Open category

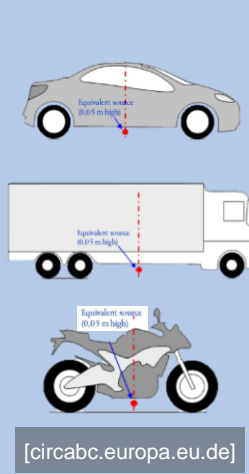

[circabc.europa.eu.de]

CNOSSOS-EU vehicle sound source description [EUR15]

- » CNOSSOS-EU source description is based on fixed sound power coefficients (see below)
- » Speed-independent (A-coefficients) & speed-dependent (B-coefficients) modeling part

Reality

Source



[www.ford.de]



[www.unsplash.com]

(a) Table F-1 is replaced by the following:

Category	Coefficient	63	125	250	500	1 000	2 000	4 000	8 000
1	A_R	83,1	89,2	87,7	93,1	100,1	96,7	86,8	76,2
	B_R	30,0	41,5	38,9	25,7	32,5	37,2	39,0	40,0
	A_P	97,9	92,5	90,7	87,2	84,7	88,0	84,4	77,1
	B_P	-1,3	7,2	7,7	8,0	8,0	8,0	8,0	8,0
2	A_R	88,7	93,2	95,7	100,9	101,7	95,1	87,8	83,6
	B_R	30,0	35,8	32,6	23,8	30,1	36,2	38,3	40,1
		105,5	100,2			101,0	97,8		

[EUR15] [EUR21]

» **CNOSSOS-EU: A method for calculating ambient noise with the goal of strategic noise mapping**

Model

Different vehicle categories:

1. Light motor vehicles
2. Medium heavy vehicles
3. Heavy vehicles
4. Powered two-wheelers
5. Open category

[circabc.europa.eu.de]

Reality

Source

[www.ford.de]

[www.unsplash.com]

CNOSSOS-EU vehicle sound source description [EUR15]

» Noise emission as a function of vehicle speed and frequency (equation based)

» Rolling noise $L_{WR} = A_R + B_R \cdot \log\left(\frac{v}{v_{ref}}\right) + \Delta L_{WR}$

» Propulsion noise $L_{WP} = A_P + B_P \cdot \frac{v - v_{ref}}{v_{ref}} + \Delta L_{WP}$

» Overall sound level $L_W = 10 \cdot \log(10^{0.1L_{WR}} + 10^{0.1L_{WP}})$

» $v_{ref} = 70$ kph

» Correction factors

High-level description of CNOSSOS-EU

Flow chart

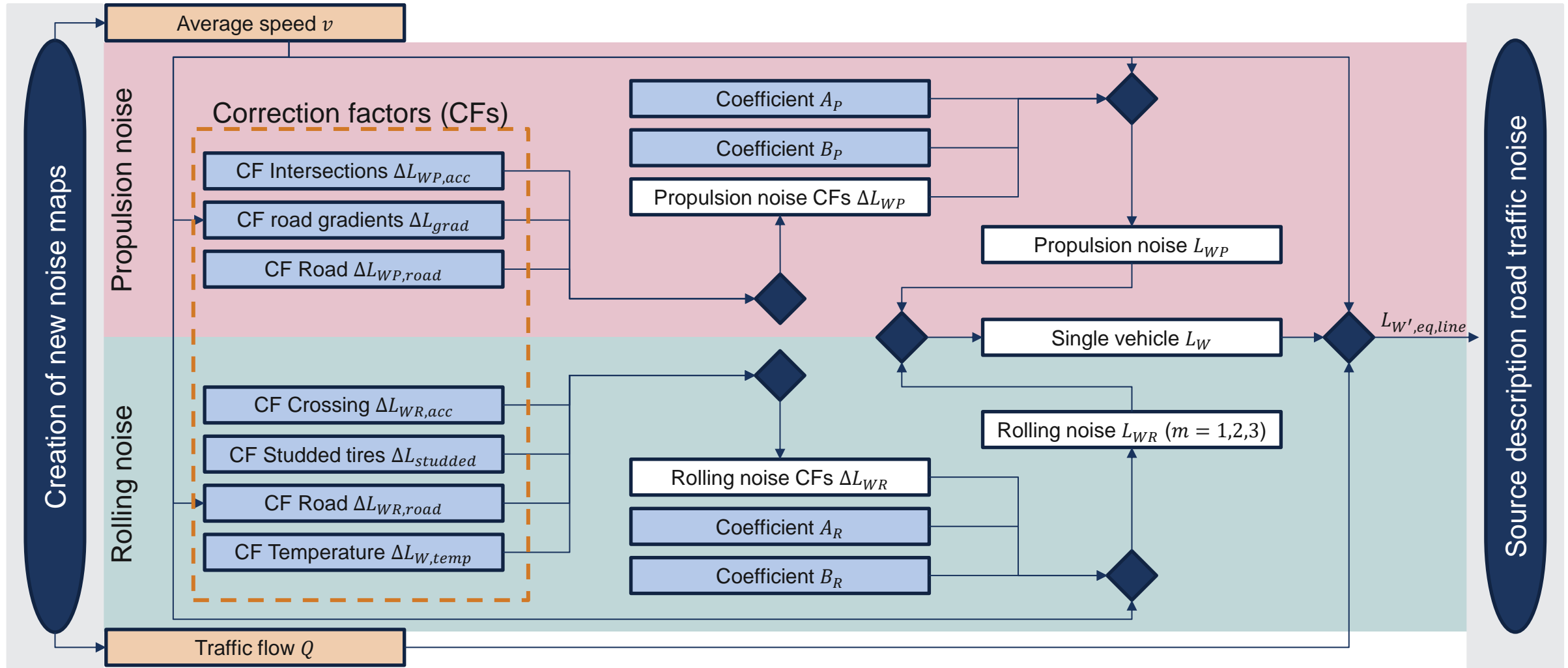

Note: For reasons of clarity, the dependence on frequency (octave band) and vehicle category is not shown

Input data Constant parameters

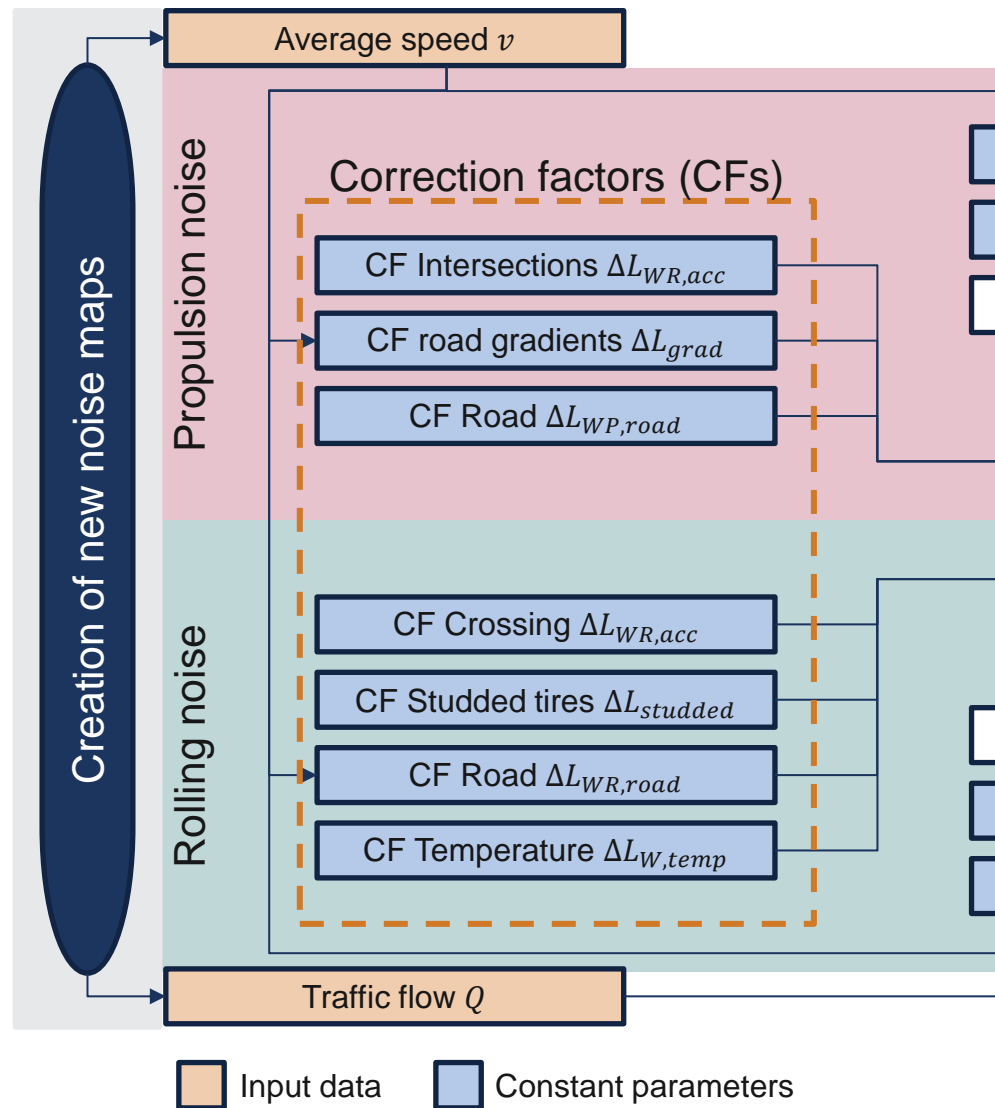

Relevant features for subsequent investigations

1. Correction factors (CFs):
 - » The extension of these enables the consideration of further influencing factors
2. Sound power coefficients A_P, B_P, A_R, B_R
 - » These were determined on the basis of several measurement campaigns
 - » Overview of underlying datasets is part of WP1.1
 - » Changes in legislation and general technological progress are not taken into account
 - » Investigation is part of WP2.1

1. Elaboration of a high-level description of the CNOSSOS-EU model

- » Derivation of the relevant model parameters and data sets for further project WPs

2. Development of an overview on road traffic noise source description models

- » Determination of suitable models for comparison

3. Overview on underlying data of the CNOSSOS-EU model

- » Until a common method was implemented, EU member states have used their own models
- » Overview of national/ regional models are shown below

#	Name	Year	Area of application
1	CNOSSOS-EU	2015	EU
2	HARMONOISE/IMAGINE	2003/2006	EU
3	NORD2000	2001/2006	Nordic Countries (SE, DK, FI, NO)
4	RLS-19	2019/2021	DE
5	NMPB-Routes/XPS 31-133	2009 (1996)	FR (CZ, LU, LV, PT, RO, SK, SI)
6	sonRoad18 (StL86+)	2018	CH
7	RMG:SRM II	2012	NL
8	RVS 04:02:11	2006/2021	AT
9	CRTN	1998	UK
10	TNM 3.1	2021	US
11	ASJ RTN-Model 2013	2018	JP

European attempts to achieve the goal of common models for noise mapping → This projects objectives

- » Until a common method was implemented, EU member states have used their own models
- » Overview of national/ regional models are shown below

#	Name	Year	Area of application
1	CNOSSOS-EU	2015	EU
2	HARMONOISE/IMAGINE	2003/2006	EU

European attempts to achieve the goal of common models for noise mapping → This projects objectives

HARMONOISE

- » Goal: Development of a suitable candidate for common noise mapping modeling
- » Approach: common road traffic noise source model for average European road vehicles
- » Result: New and significantly more complex model

IMAGINE

- » Goal: Further development of HARMONOISE model with the aim to:
 1. Include industrial and aircraft noise
 2. Extend the source databases for road traffic noise

CNOSSOS-EU

- » Goal: Establishment of Common Noise aSSessment methOdS (CNOSSOS-EU)

[ABB02] [ECO12] [KEP12]
[EU15] [IMA07] [ZHA14]

Overview of road traffic noise models

Relations between models

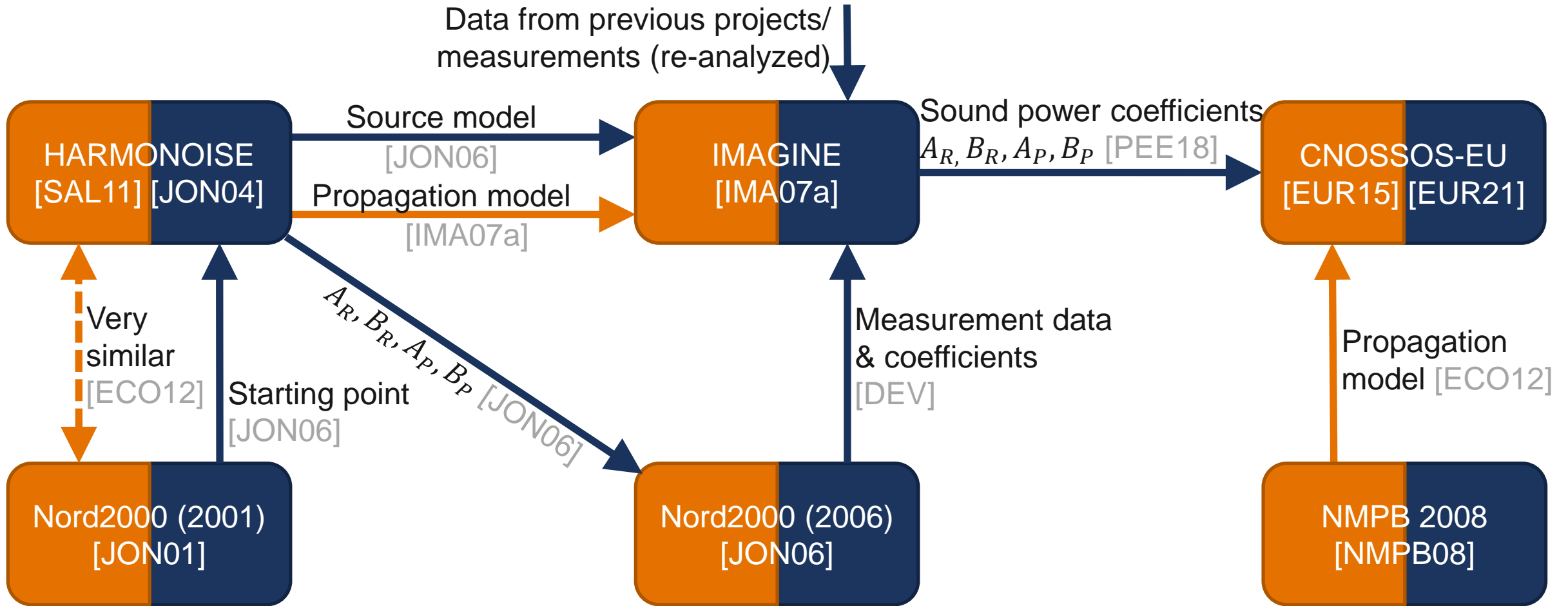

■ Source model ■ Propagation model

Overview of road traffic noise models

Relations between models

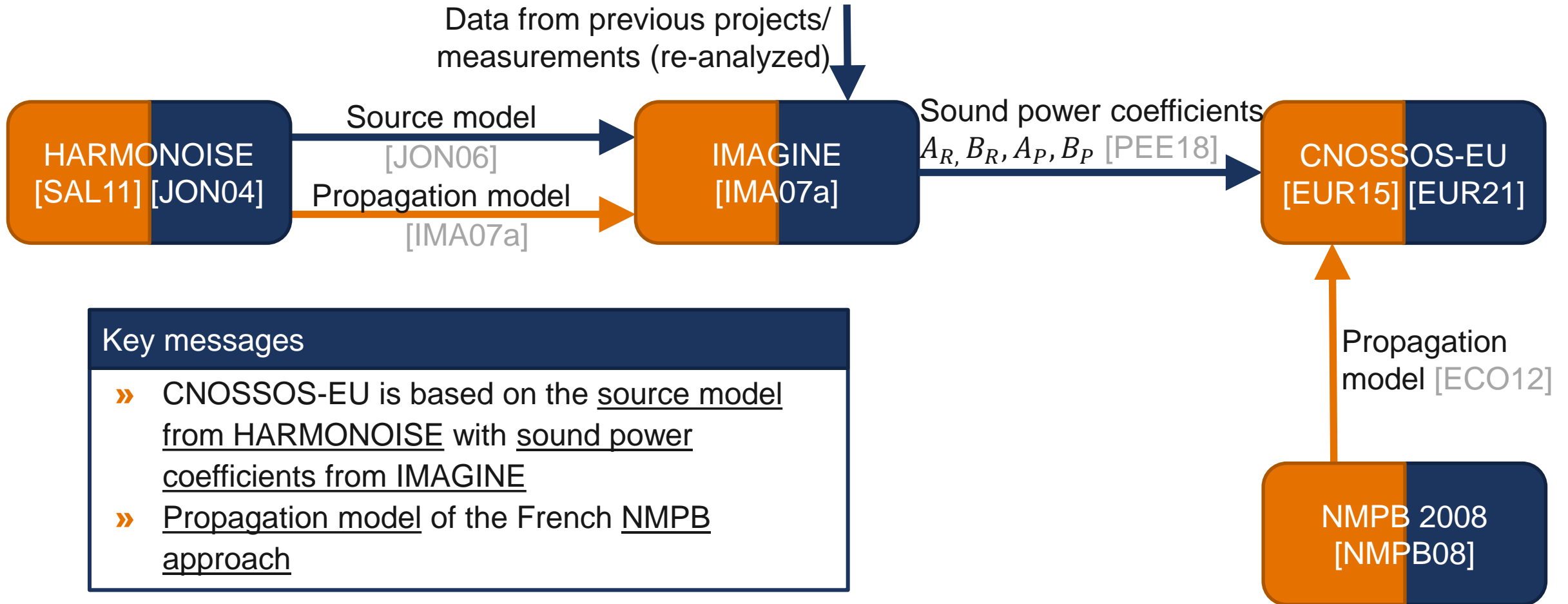

Key messages

- » CNOSSOS-EU is based on the source model from HARMONOISE with sound power coefficients from IMAGINE
- » Propagation model of the French NMPB approach

■ Source model ■ Propagation model

Overview of road traffic noise models

Flow chart for CNOSSOS-EU (from slide 13)

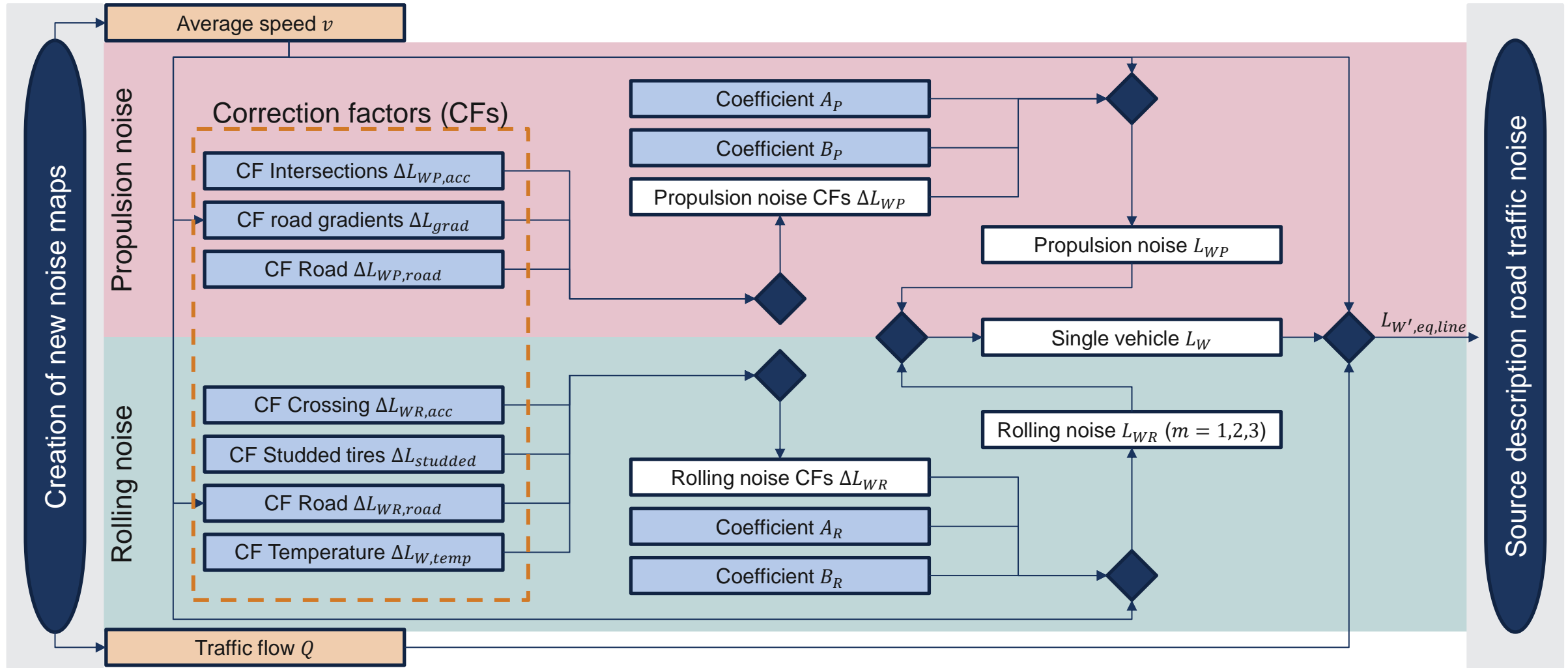

Note: For reasons of clarity, the dependence on frequency (octave band) and vehicle category is not shown

Input data
 Constant parameters

Overview of road traffic noise models

Flow chart for CNOSSOS-EU (from slide 14)

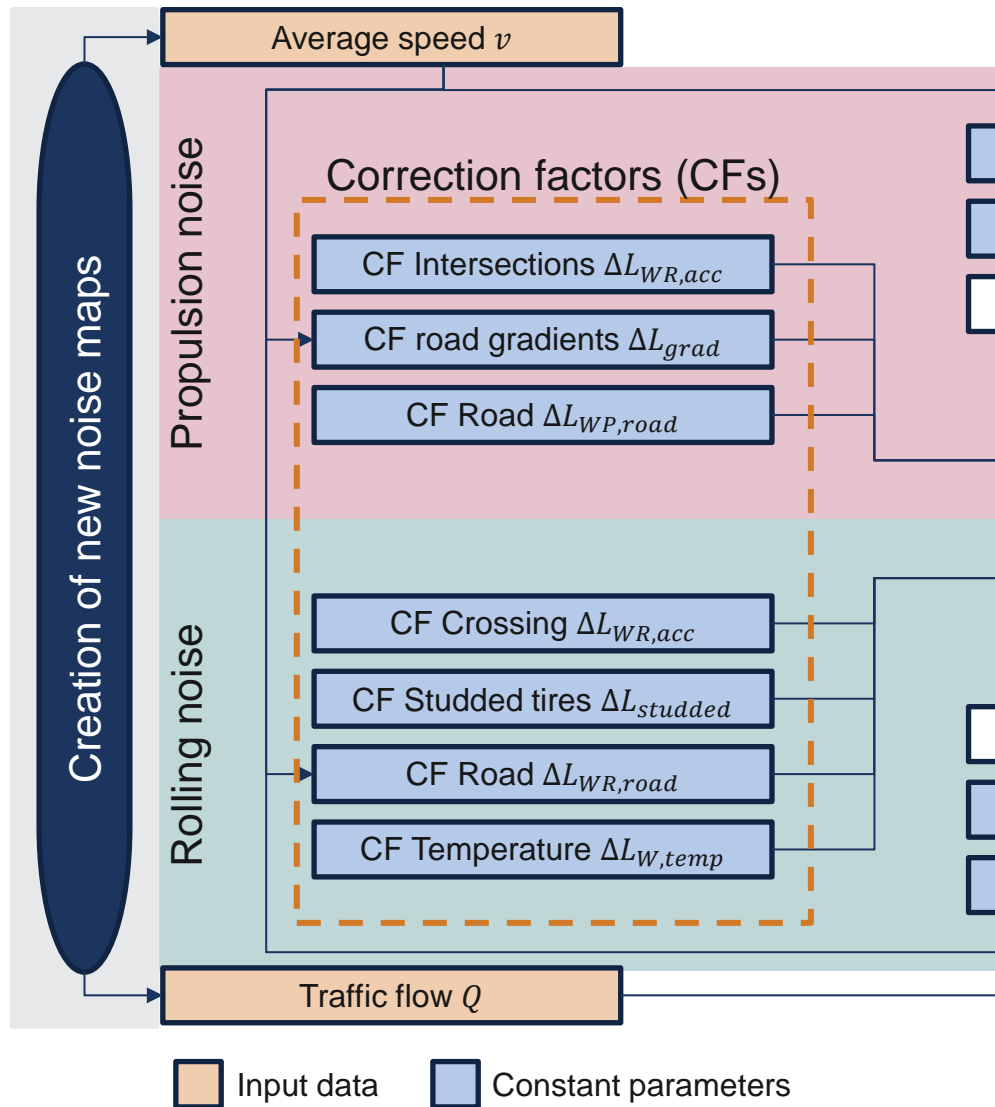

Relevant features for subsequent investigations

1. Correction factors (CFs):
 - » The extension of these enables the consideration of further influencing factors
2. Sound power coefficients A_P, B_P, A_R, B_R
 - » These were determined on the basis of several measurement campaigns
 - » Overview of underlying datasets is part of WP1.1
 - » Changes in legislation and general technological progress are not taken into account
 - » Investigation is part of WP2.1

Overview of road traffic noise models

Flowchart for HARMONOISE/IMAGINE

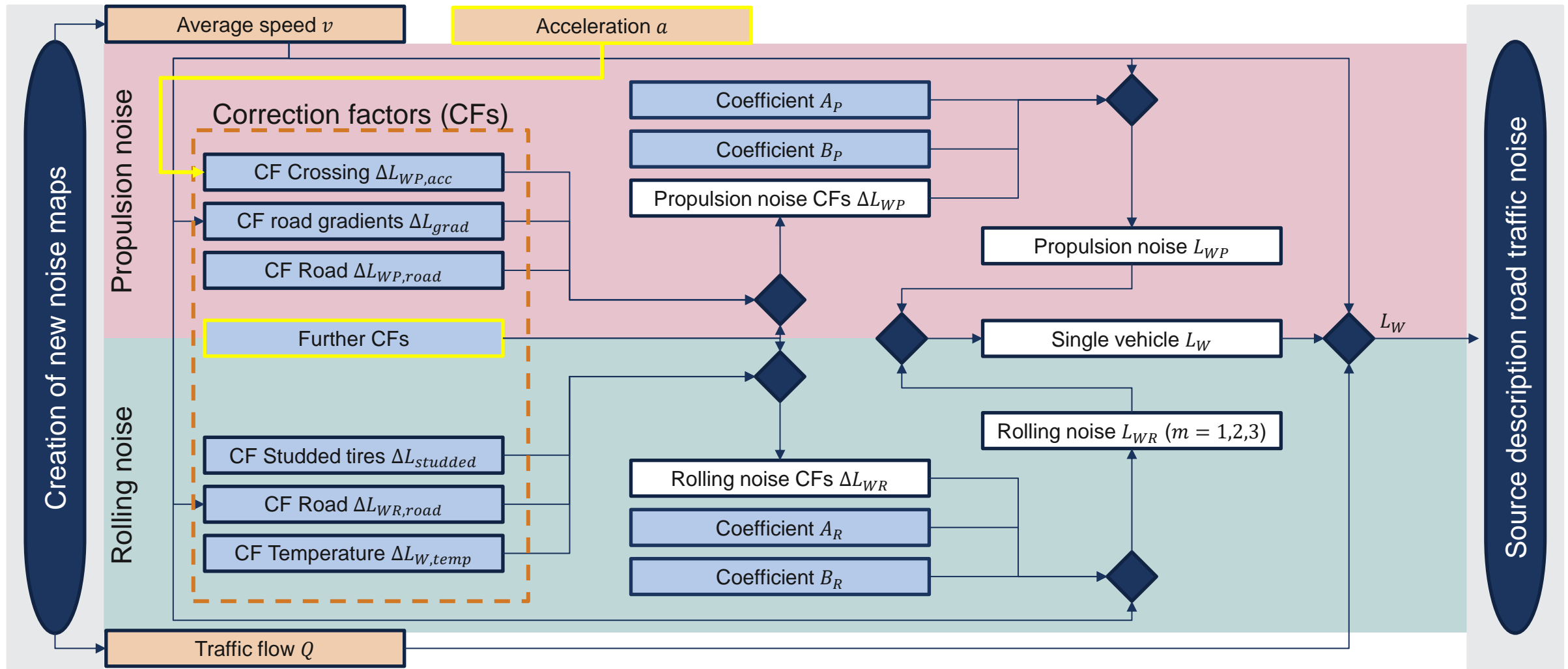

Note 1. For reasons of clarity, the dependence on frequency (1/3-octave band) and vehicle category is not shown
 2. Some calculations & correction values change. Only the relation of similar values & parameters is depicted

Input data Constant parameters

Overview of road traffic noise models

Flowchart for HARMONOISE/IMAGINE

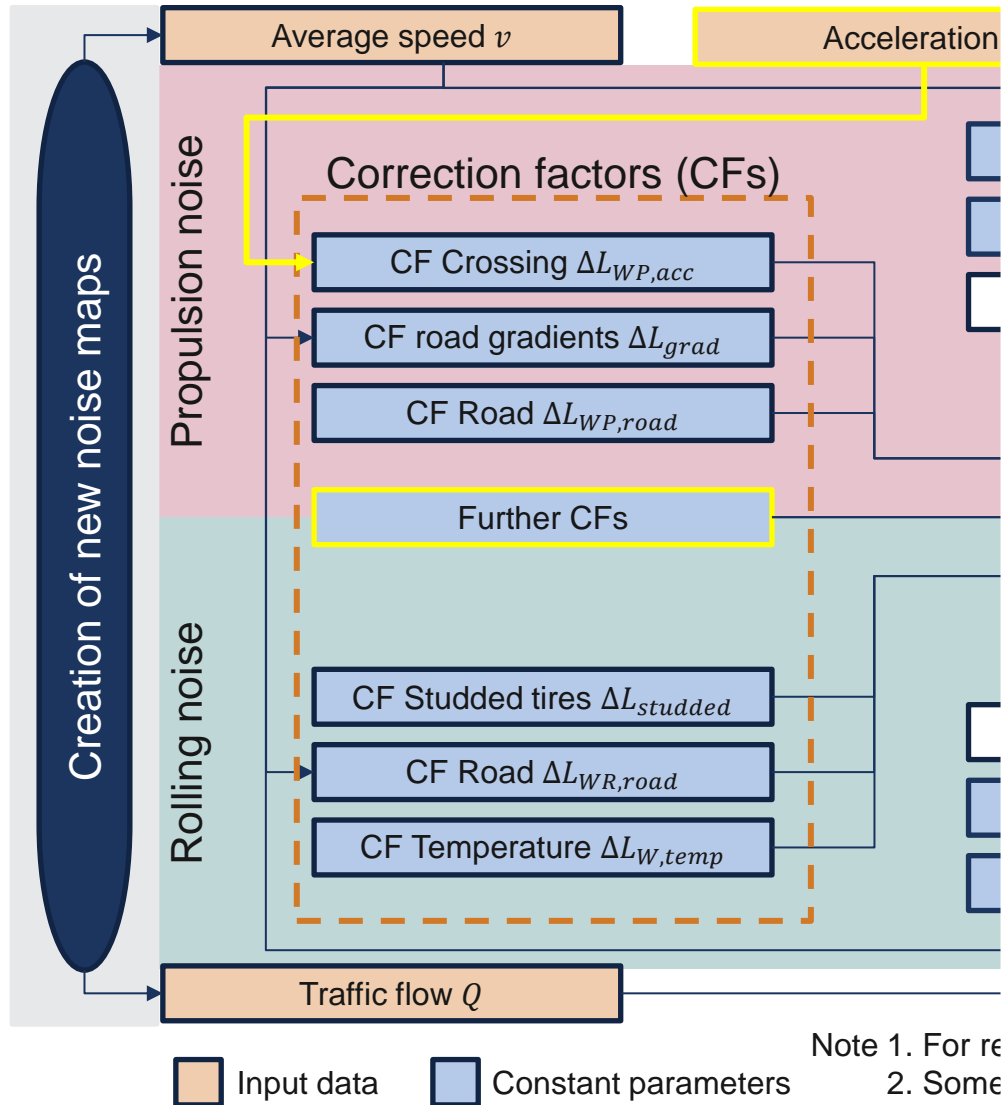

Main differences

The source description models are similar, however:

1. Acceleration is a further input in HARMONOISE/ IMAGINE
2. No 5th open vehicle category in HARMONOISE/ IMAGINE
3. Different source locations/ height
4. Additional correction factors (CFs) are taken into account in HARMONOISE/ IMAGINE, e.g.:
 - » Number of axles (HDV)
 - » Directivity of sources
 - » Further regional differences
 - » Diesel/gasoline
 - » Average vehicle weight & age
 - » Tire width & type (winter/summer)
 - » Illegal silencer systems

Source description models for traffic noise

Nord2000 – Flow chart

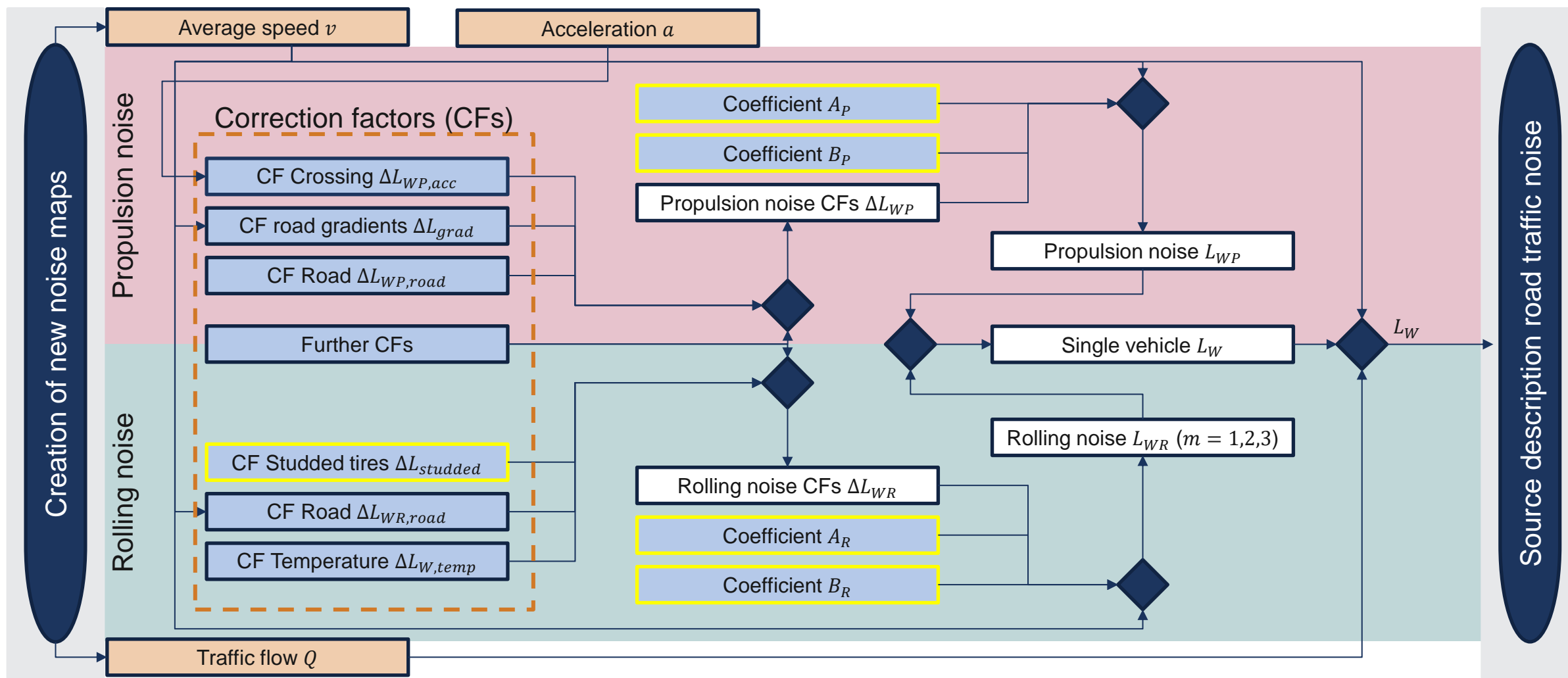

Input data

Constant parameters

Note: For reasons of clarity, the dependence on frequency (1/3-octave band) and vehicle category is not shown

Source description models for traffic noise

Nord2000 – Flow chart

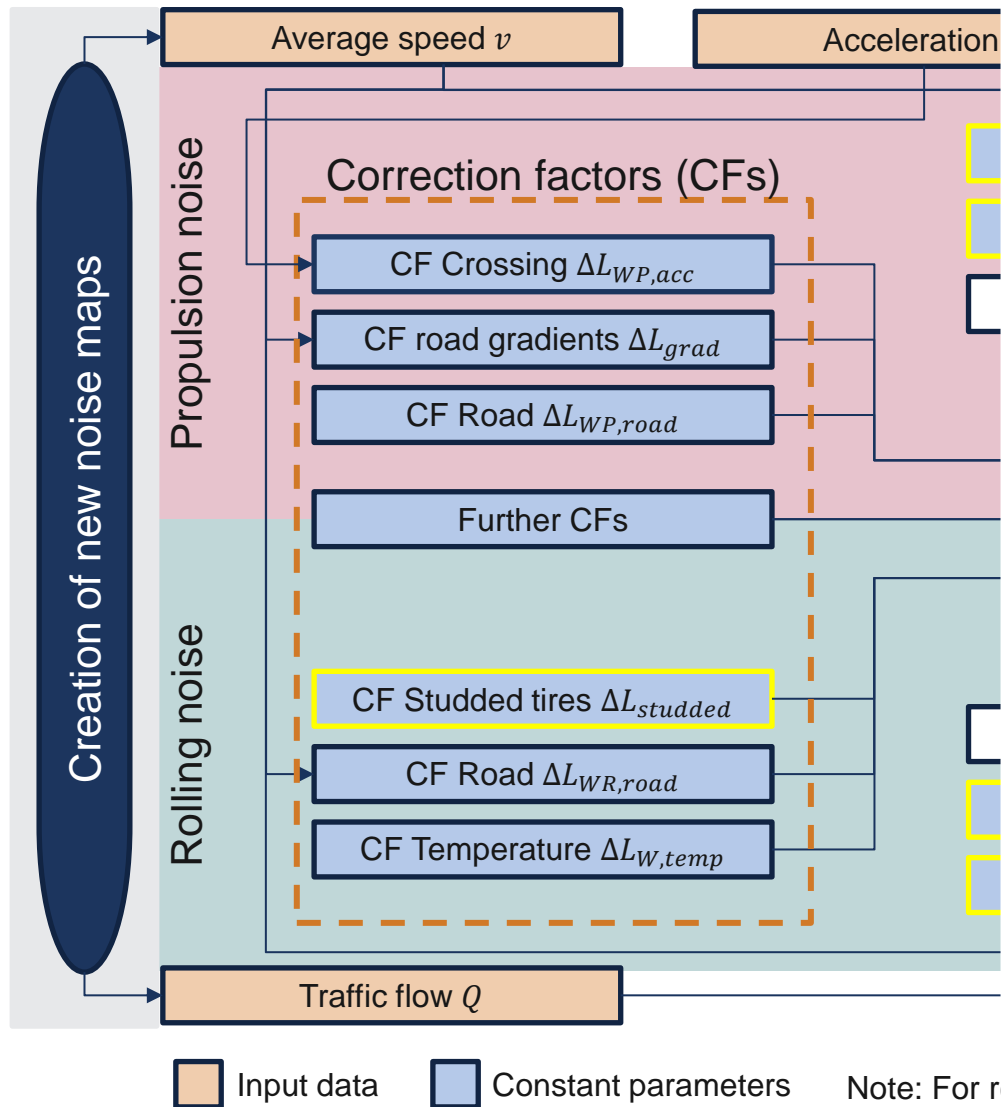

Main differences

The source description models HARMONOISE and Nord2000 are very similar, however certain modifications have been made:

1. Regional corrections to A_R
2. Corrections to speed coefficients B_P and B_R and to A_P
3. Corrections for studded tires are modified
4. Horizontal directivity of rolling noise is modified

CNOSSOS-EU

- » Constant vehicle speed
- » Reference vehicle speed $v_{ref} = 70$ kph
- » A flat road (non-sloped)
- » Air temperature 20 °C
- » Road surface
 - » Mixture of DAC 0/11 & SMA 0/11
 - » ≥ 2 years & < 7 years
 - » Dry
 - » Sound reflecting
- » No studded tires
- » Vehicle fleet representing European average, e.g. Category 1: 187mm tire width, 19% diesel, 10.5% delivery vans, no studded tires

HARMONOISE/IMAGINE

- » Constant vehicle speed
- » Reference vehicle speed $v_{ref} = 70$ kph
- » A flat road (non-sloped)
- » Air temperature 20 °C
- » Road surface
 - » Mixture of DAC 0/11 & SMA 0/11
 - » ≥ 2 years (not at life time end [IMA07])
 - » Dry
 - » Sound reflecting
- » No studded tires
- » Vehicle fleet representing European average, e.g. Category 1: 187mm tire width, 19% diesel, 10.5% delivery vans, no studded tires

Overview of road traffic noise models

Reference conditions for CNOSSOS-EU & HARMONOISE/IMAGINE



CNOSSOS-EU

- » Constant vehicle speed
- » Reference vehicle speed $v_{ref} = 70$ kph
- » A flat road (non-sloped)
- » Air temperature 20 °C
- » Road surface
 - » Mixture of DAC 0/11 & SMA 0/11
 - » ≥ 2 years & < 7 years
 - » Dry
 - » Sound reflecting
- » No studded tires
- » Vehicle fleet representing European average, e.g. Category 1: 187mm tire width, 19% diesel, 10.5% delivery vans, no studded tires

Nord2000

- » Constant vehicle speed
- » Reference vehicle speed $v_{ref} = 70$ kph
- » A flat road (non-sloped)
- » Air temperature 20 °C
- » Road surface
 - » Mixture of DAC 0/11 & SMA 0/11
 - » ≥ 2 years (not at life time end [JON06])
 - » Dry
 - » Sound reflecting
- » No studded tires
- » By using new Nordic data, regional differences in vehicle fleet, road surfaces and studded tires are accounted for

- 1. Elaboration of a high-level description of the CNOSSOS-EU model**
 - » Derivation of the relevant model parameters and data sets for further project WPs

- 2. Development of an overview on road traffic noise source description models**
 - » Determination of suitable models for comparison

- 3. Overview on underlying data of the CNOSSOS-EU model**

- » **Several measurement campaigns have been conducted**
 - » Within IMAGINE
 - » From further projects/models (e.g. Nord2000 (2006) [DEV])

- » **Differentiation between rolling noise and propulsion noise**
 - » Test drives using on-board measurement equipment
 - » Pass-by measurements on test tracks
 - » Coast-by measurements on test tracks

- » **Final adjustment/calibration of sound power level by means of pass-by measurements at roadside in Italy, Denmark, Poland, Netherlands and UK**

- » **Detailed information can be found in the project report [IMA07a] and in [PEE18]**

Overview on underlying data sets

IMAGINE – Available data

» Data that was already during IMAGINE available and reanalyzed

#	Measurement	Provided by	Acquired in
1	Rolling noise levels (15 truck tires, 12 surfaces)	M+P	2003
2	Data on driving conditions of two-wheelers	IMMA	2000
3	Pull-away m. (measurements) HDV	TRL	
4	Coast-by m. of trucks	TRL	
5	Sound emission level of traffic	M+P & TRL (SILVIA project)	2004
6	Controlled Pass-By m.	Autostrade	
7	Rolling noise m. for light motor vehicles & trucks	M+P (for ACEA)	
8	Propulsion noise for light motor vehicles	TUG (VENOM)	
9	NORD2000 data, transfer functions & calculations	SP (Sweden)	

Because the IMAGINE lasted from 2003 to 2006 and this data was already available during the project, this data can only be from 2005/2006 or earlier

» Data that was acquired during IMAGINE in WP5 (1/2)

#	Measurement	Conducted by	Acquired in
1	On-board m. of Powered Two-Wheelers	M+P	2004
2	Propulsion noise laboratory m. of HDVs	Volvo	2005
3	Outdoor noise m. of HDV at test track/roundabout	Volvo / SP	2005
4	Pass-by m. at UK highway	TRL	2005
5	Pass-by m. in Nordic countries	SP	2005
6	Pass-by m. in Poland	TUG	2005
7	Pass-by m. in Poland	TUG / M+P	2006
8	Pass-by m. in Italy	M+P	2006

“Separate reports have been written for some of these campaigns” [IMA07a]

» Data that was acquired during IMAGINE in WP5 (2/2)

#	Measurement	Conducted by	Acquired in
9	Pass-by m. on several locations in NL	M+P	2006
10	Pass-by m. on scooters, motorcycles in Italy	JRC / Autostrade	2005
11	Pass-by m. on powered two-wheelers GR (Mykonos)	JRC / TUG	2006
12	Pass-by m. of trucks at low velocities	M+P	2006
13	Pass-by m. of Powered two-wheelers	M+P	2005
14	Pass-by m. of accelerating traffic	M+P	2005
15	Stop and go m. at Italian motorway toll station	Autostrade	2006
16	Statistical data gathering	M+P, TRL, JRC	2004 - 2006

“Separate reports have been written for some of these campaigns” [IMA07a]

The following slides (33-47) are only intended to show different measuring methods exemplarily

Information on measurement campaigns

- » M+P and Müller-BBM conducted measurements in 1997-2001 for the German Federal Highway Research Institute (BASt) in order to derive a rolling noise emission model [BEC01]:
 - » 42 different road surfaces on a test track in Sperenberg (DE)
 - » 2 different vehicles
 - » 8 tires for each vehicle (& 4 truck tires)
 - » Measurements of road parameters (absorption, textures, ...)
- » The data has been reanalyzed for HARMONOISE/IMAGINE

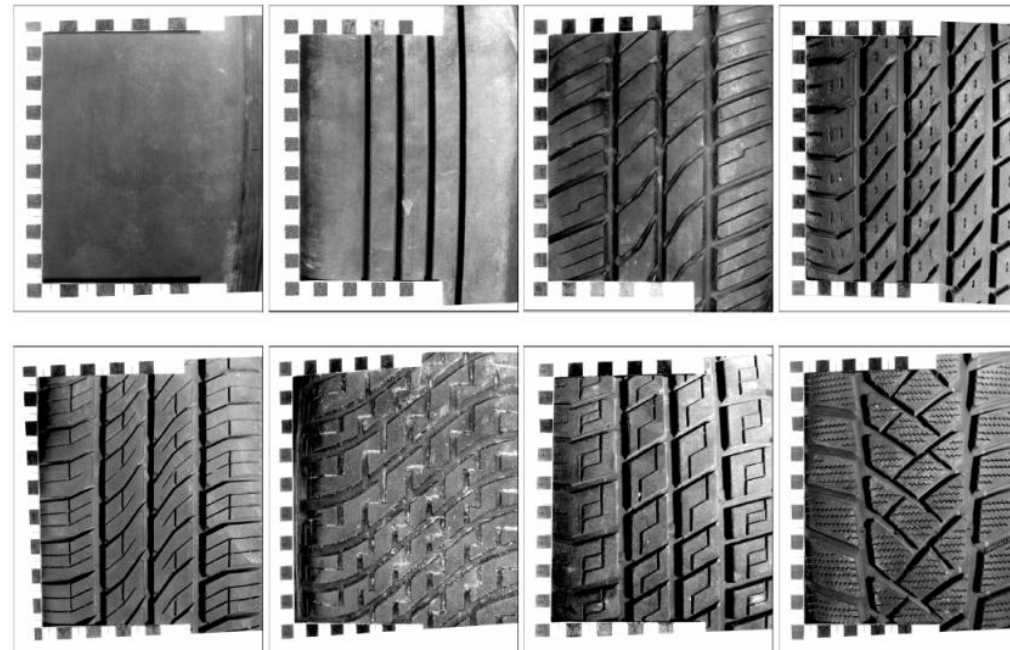

Information on measurement campaigns

- » TU Gdansk (TUG) and VTI Sweden developed a model for pass-by noise prediction for category 1 vehicles
 - » Based on vehicle speed, acceleration & gear
- » TUG coefficients A_P , B_P , C_P derived by analyzing the maximum sound pressure level measured
- » The coefficients agree well compared to the default values from HARMONOISE
- » NOTE: The coefficients found by TU Gdansk depicted in the graph are smoothed, leading to underestimated levels around 80 Hz
- » Detailed information in IMAGINE report IMA05TR-060301-TUG03 (not available publicly)
- » No information on year of acquisition

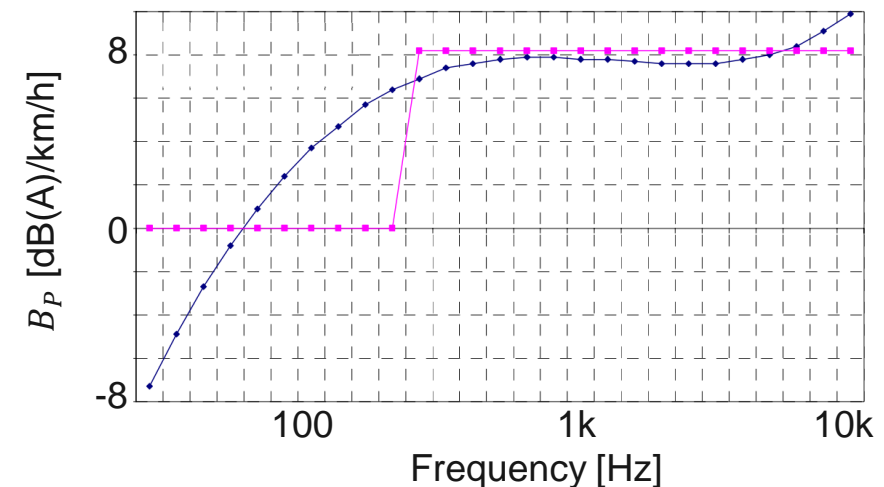
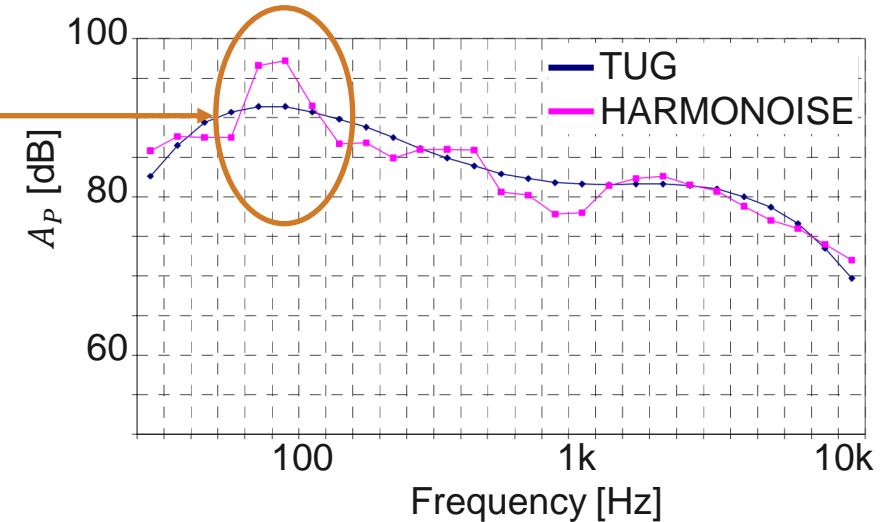

Information on measurement campaigns

- » M+P conducted pass-by measurements for the Dutch Ministry of Transport (“Innovatieprogramma Geluid”):
 - » Microphone: 7.5 m aside and 1.2 m height (sound exposure level SEL & L_{max})
 - » 15 truck tires
 - » Steering (rib profile)
 - » Traction (block profile)
 - » Trailer (block profile)
 - » New and worn conditions
 - » 12 surfaces
 - » Speed range 45 - 95 km/h
 - » A_R & B_R
- » No detailed information on interim report number

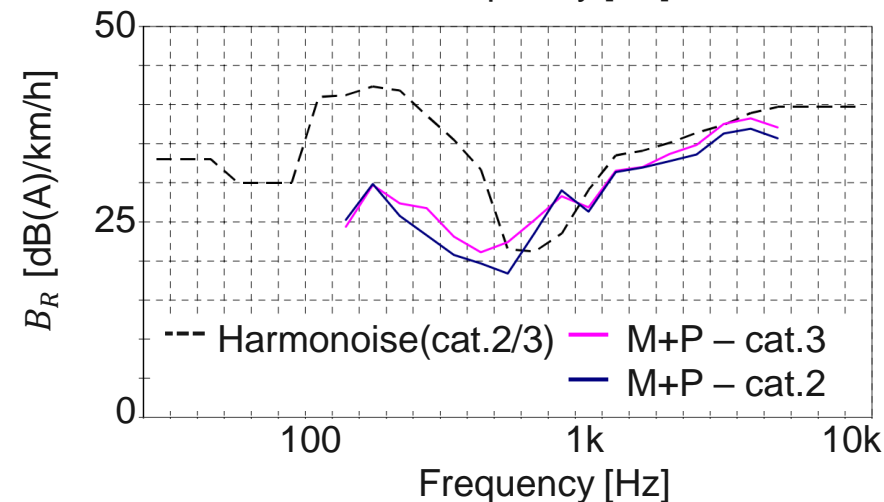
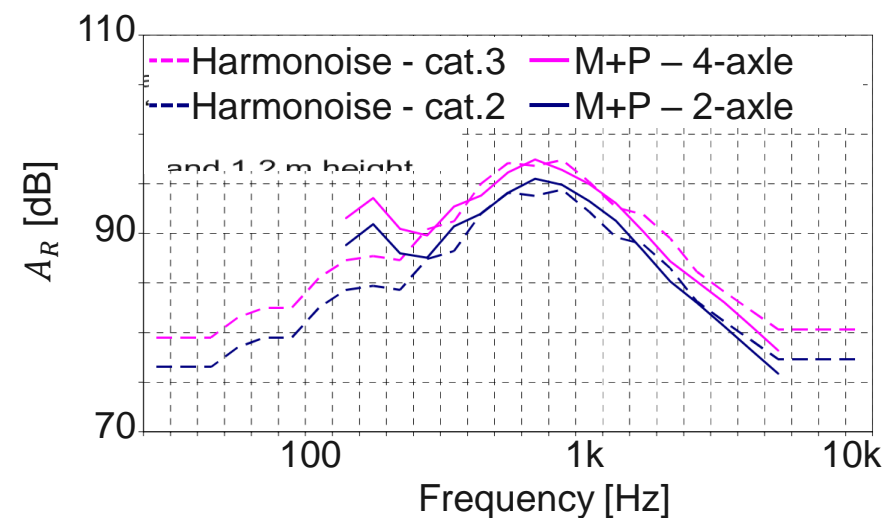

Information on measurement campaigns

- » Conducted by Volvo in 2005:
 - » According to ISO 3744 method
 1. Only driveline (upper figure)
 2. Full truck with covered rear wheels on dynamometer (lower figure)
 3. Simulated city cycles
 - » Driving conditions for 1. and 2.:
 - » For different gears at constant speed
 - » Varying: Load, gradient, ...
 - » Acceleration from 0 – 70 km/h
 - » Braking
- » Detailed information in IMAGINE report IMA05TR-050618-Volvo01



Information on measurement campaigns

- » Transport Research Laboratory (TRL) in the UK performed acceleration measurements „pull-away“ from stand still
 - » In this condition, the rolling noise can be neglected
 - » Factor ~ 8 dB(A) per 1 m/s^2 for three of the tested vehicles; significant deviations for further vehicles
 - Overestimation of acceleration dependency
 - Especially for normal traffic
 - HARMONOISE assumes 5.6 dB(A) per 1 m/s^2
- » No detailed information on interim report number

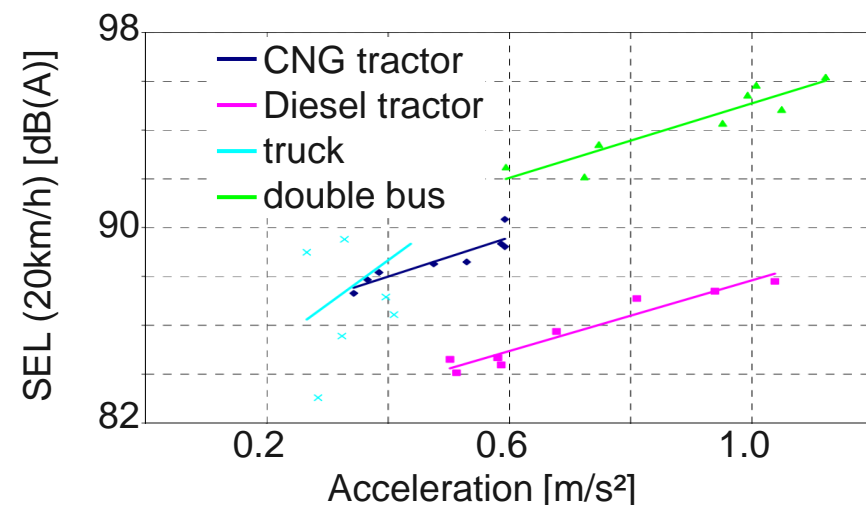

Information on measurement campaigns

- » City-driving was conducted by M+P with on board systems on three vehicles
 1. 50 cc scooter with automatic transmission
 2. 80 cc moped with manual transmission
 3. 885 cc motorcycle with 3 cylinders & manual transmission
- » Data acquisition
 - » Sound pressure at engine intake & exhaust
 - » Further quantities: Speed, engine speed & throttle position (→ acceleration)
- » Data analysis
 - » Coefficients A_p and B_p from averaging the two positions
- » No detailed information on interim reports

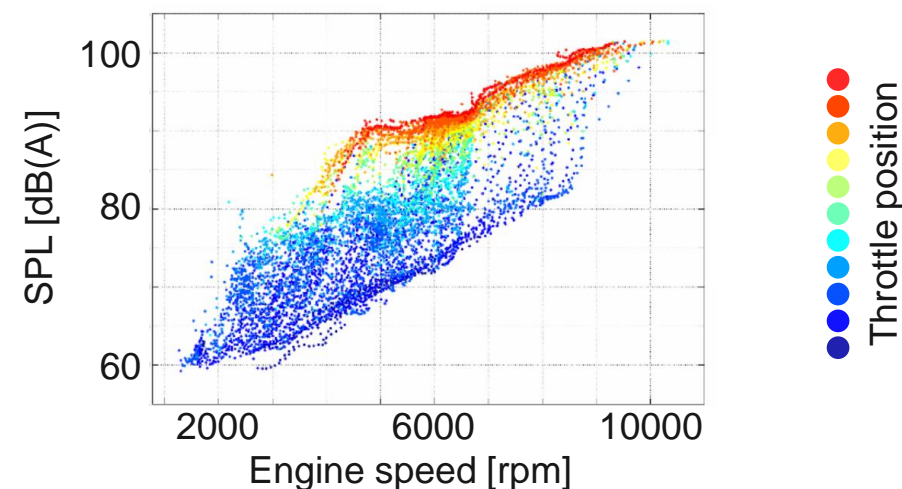
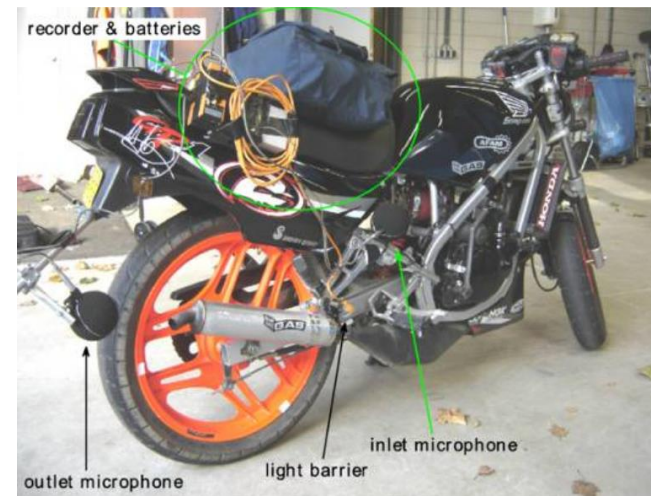

Category 4 (powered two-wheelers)

- » Conducted by TUG, JRC, M+P & Autostrade
- » Places and times with high expected number of cat. 4 vehicles were expected (2005-2006)
 - » NL Assen: International motorcycle race
 - » NL river Waal: Organized country-side tour
 - » GR Mykonos (seen in image below)
 - » IT city road



Category 1 (light motor vehicles)

- » Conducted by M+P at an intersection
- » Investigation of the influence of acceleration on the propulsion noise
 - » Issue 1: Difference between acceleration & speed
 - » Issue 2: Difference between rolling & propulsion

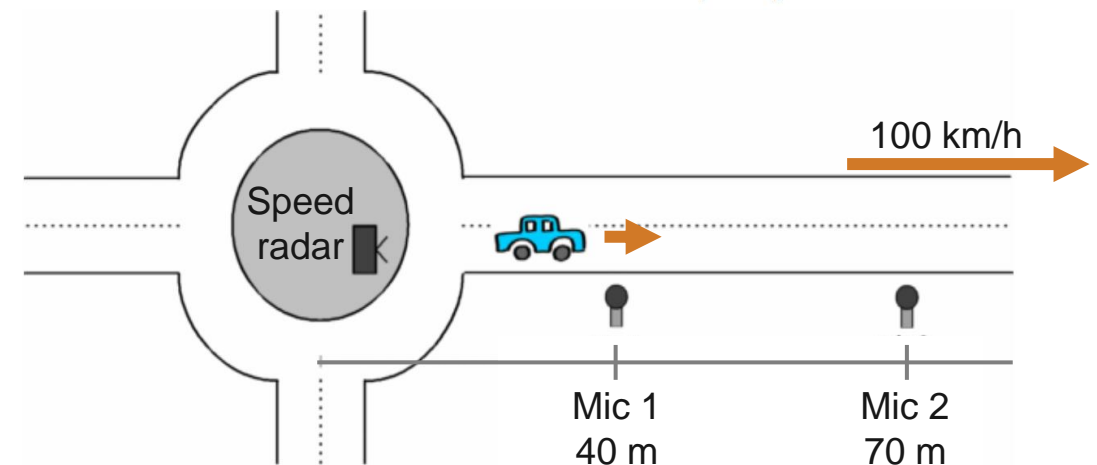

Overview on underlying data sets

Road side measurements – General information

	SPB-ISO	SPB-HI	SPB-L	U-SPB
Reference	ISO/DIS 11819-1 [10]	HARMONOISE/IMAGINE [35,36]	LEOPOLDO [31,32]	NEREIDE [29]
Parameter	L_{Amax}	SEL	SEL	SEL
Microphone heights	1 mic at 1.2 m height	2 mics at 1.2 m and 3 m height	2 mics at 1.2 m and 3 m height	1 mic at 4 m height
Measurement distance from road lane	7.5 m	7.5 m	7.5 m	3–15 m
Measurement conditions	Attended	Attended	Attended	Unattended
Events triggering	On site	On site	On site	In lab by use of counter traffic
Fitting technique	Linear fit	Linear fit	Binning linear fit	Binning linear fit

[ASC22]

Difference between ISO 11819-1 (SPB) and road side measurements during IMAGINE (SBP-HI)

- » Parameter
 - » Standardized SPB uses $L_{A,max}$
 - » SPB-HI uses SEL (sound exposure level) from ISO 1996-1 [ISO16]

- » Microphone height
 - » Additional height of 3 m

Overview on underlying data sets

Road side measurements – $L_{A,max}$

$L_{A,max}$ [ISO22a] [ISO22b]

» $L_{A,max}$ is the maximum A-weighted sound pressure level recorded during pass-by measurements

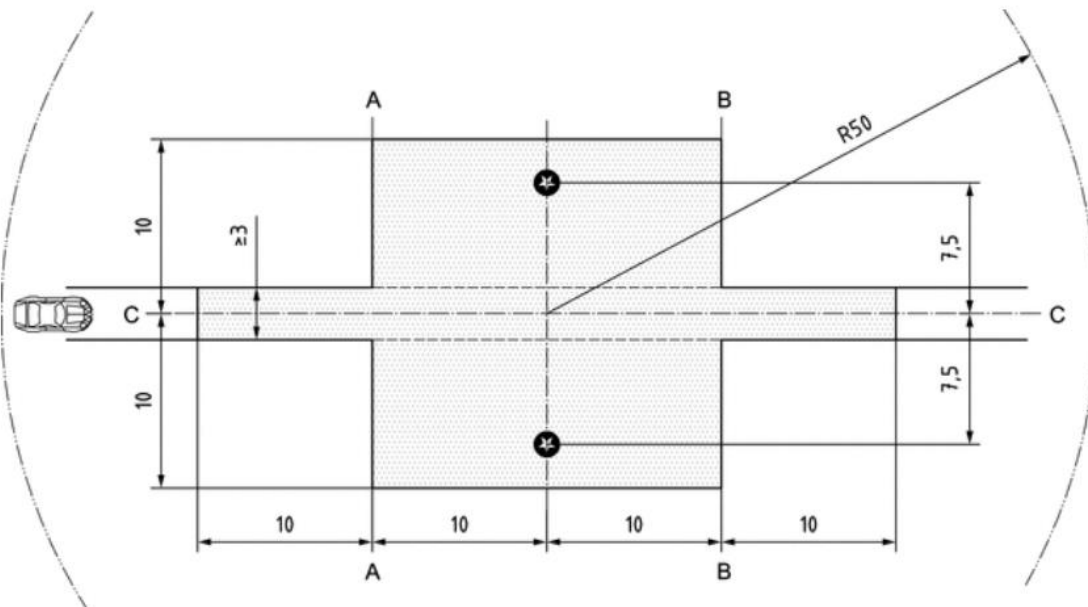

Microphone height 1.2 m

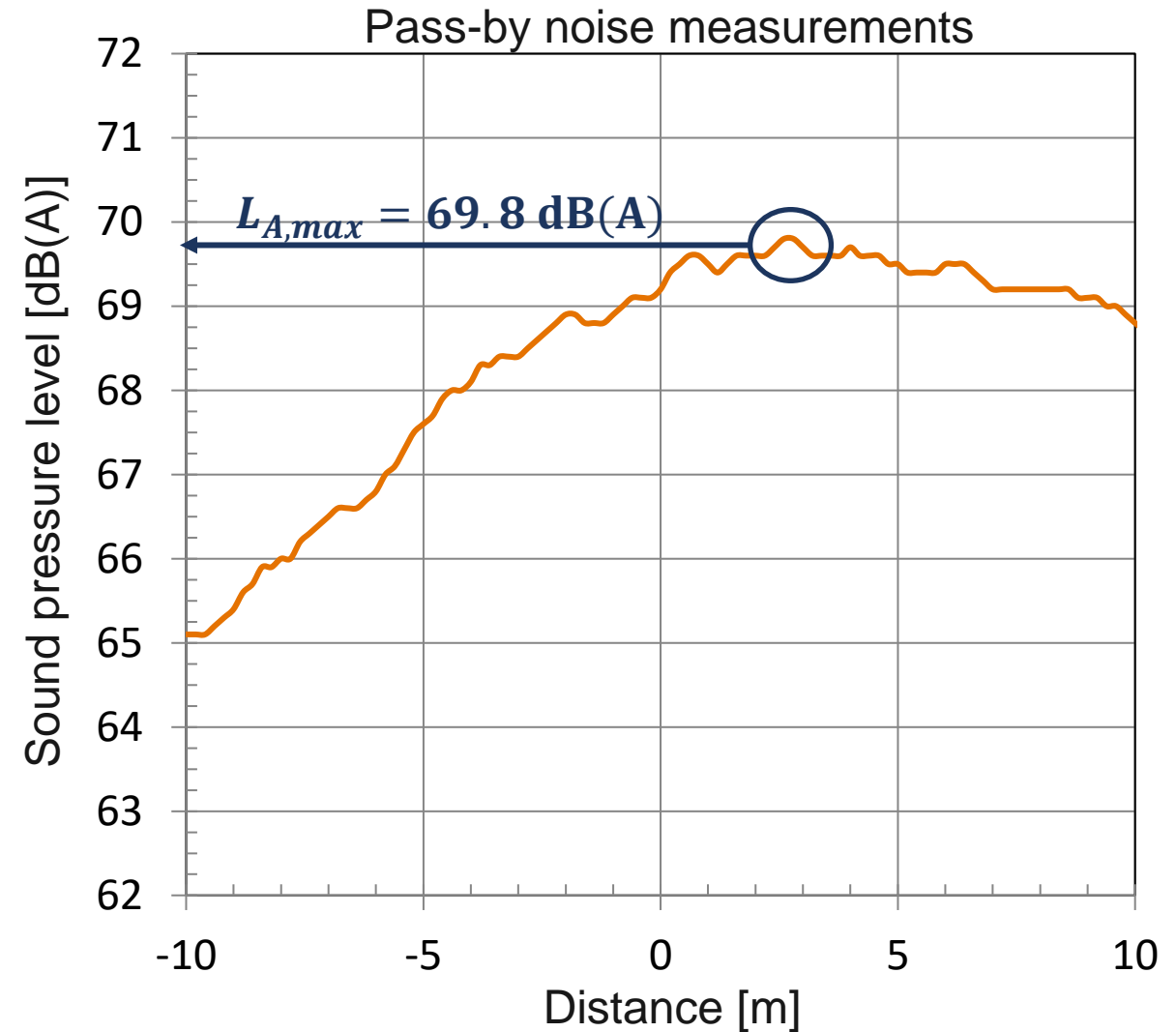

Sound exposure level [ASC22]

- » “SEL was chosen by the NORDTEST method, HARMONOISE, IMAGINE [...] projects for its representativeness in noise models and its ability to estimate the overall noise levels”

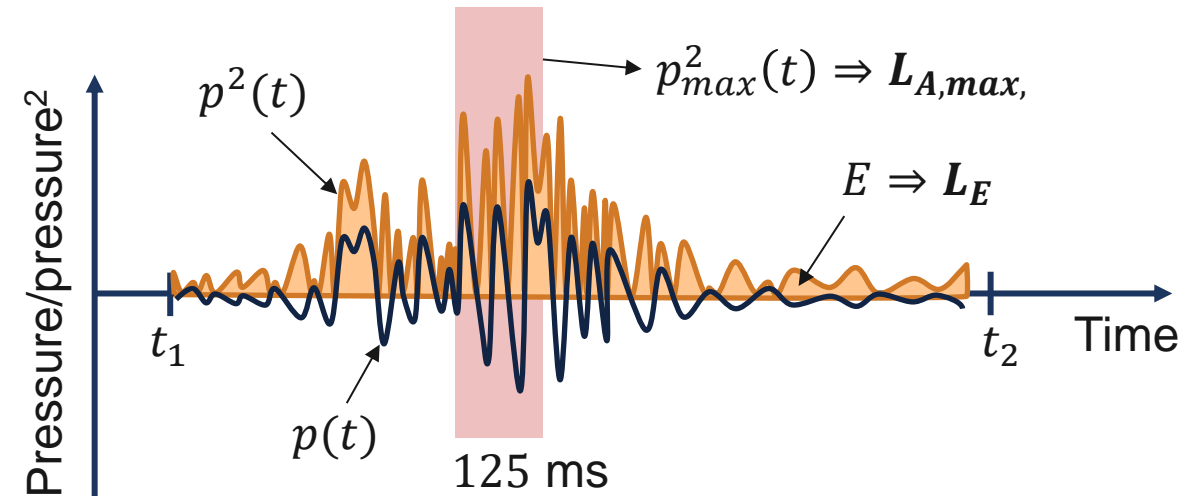

$L_{A,max}$ vs SEL [ASC22]

- » “SEL was chosen by the NORDTEST method, HARMONOISE, IMAGINE [...] projects for its representativeness in noise models and its ability to estimate the overall noise levels”
- » $L_{A,max}$ “is strongly dependent on the local peculiarities of the road (such as potholes, bumps, etc.) [...] and vehicle discrepancies”
 - » “results tend not to be stable even for the same vehicle and pavement”
 - » Not the case for type approval measurements
- » SEL is more sensitive to ground effects → Second position at 3 m height

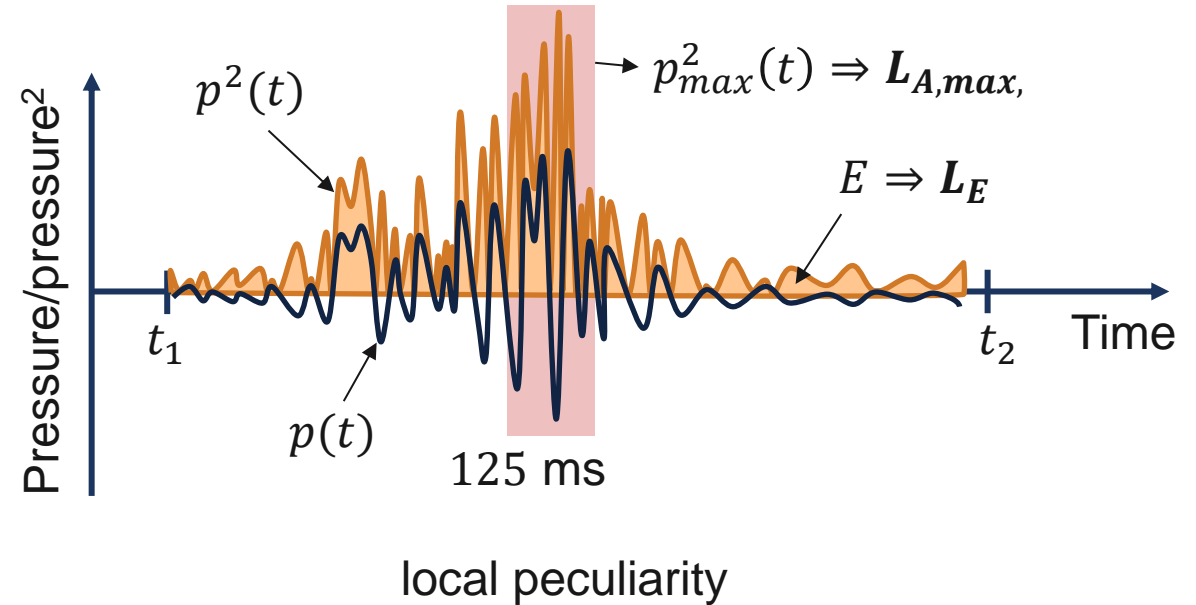

The microphone height and the investigated parameter are the main differences between SPB and the measurements during IMAGINE for the derivation of the sound power coefficients. Therefore, further information about SPB measurements is shown in the following slides.

SPB (ISO 11819-1) [ISO22b]

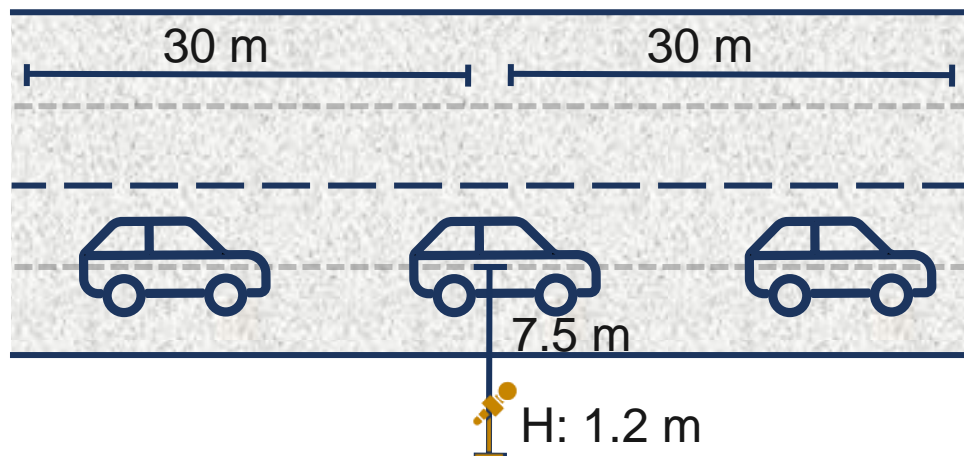

Measurement set up

- » Measurements usually on public roads
 - » Specified road section: for cars $\geq 30\text{m}$, for trucks $\geq 50\text{m}$
 - » Road must be mainly flat and straight (light turns/ gradients $\leq 2\%$ negligible)
 - » Road surface in good condition, but not new
- » Measuring several vehicles passing by
- » Requirements regarding free field conditions/no reflective objects

SPB (ISO 11819-1) [ISO22b]

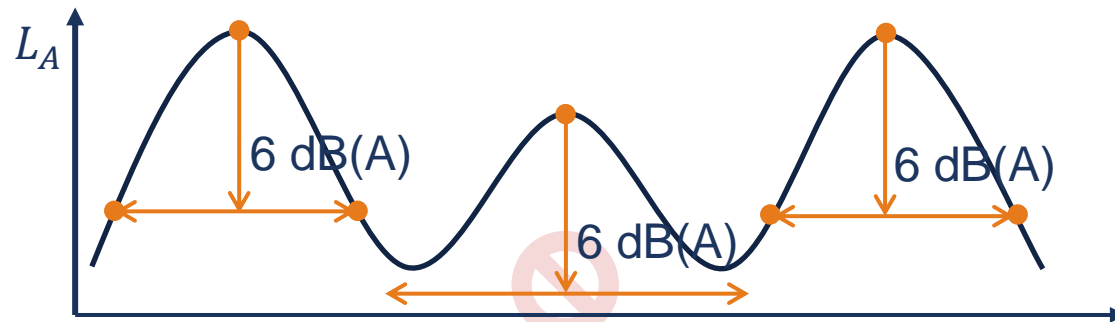
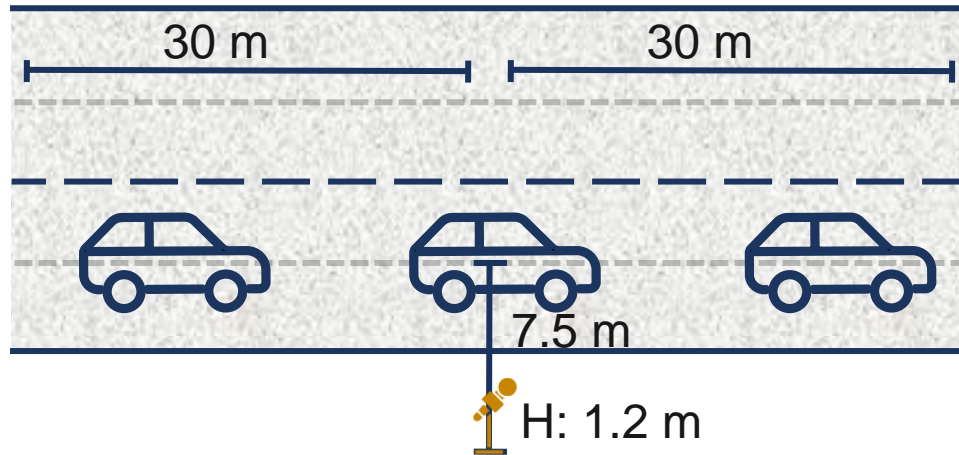

- » At least 6 dB(A) before/after a event
- » No correction values required

Speed parameter

- » Reference speeds **depending on type of road**:
 - » **Low speed**: \emptyset 45 km/h - 64 km/h
 - » **Medium speed**: \emptyset 65 km/h - 99 km/h
 - » **High speed**: \emptyset > 100 km/h
- » Vehicle speed to be measured approximately when the centre of the vehicle passes the microphone

Overview on underlying data sets

Road side measurements – Statistical Pass-by (SPB)

SPB (ISO 11819-1) [ISO22b]

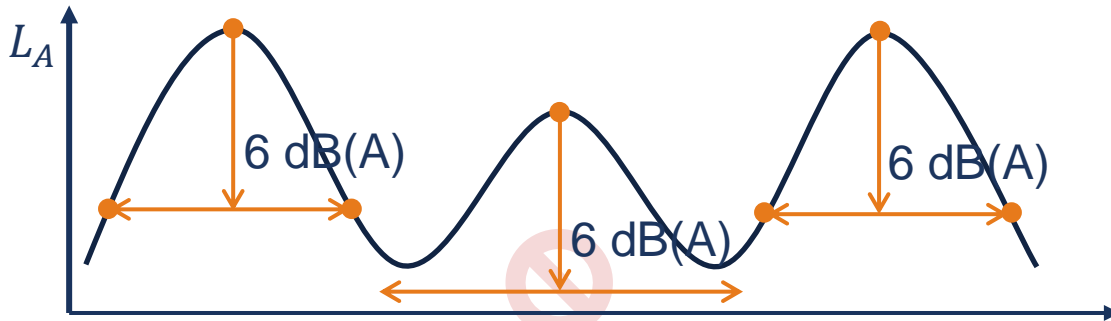
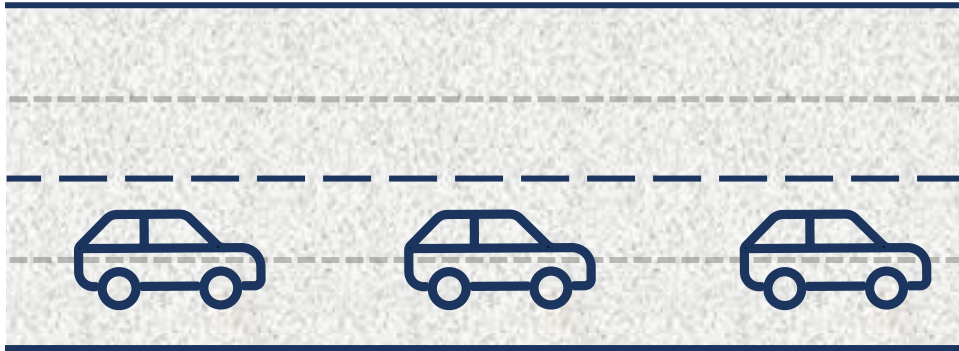

- » At least 6 dB(A) before/after a event
- » No correction values required

		Limit	Measurement accuracy
1	[°C]	5 – 35 °C	± 1°C
2	[m/s]	≤ 5 m/s	--
3	[%]	--	--
4	[hPa]	--	--

- » A correction to reference of 20°C to be applied
- » Recommended: correct every measurement
- » Correction according to ISO/TS 13471-2

[1]: Temperature; [2]: Wind speed; [3]: Humidity; [4]: Air pressure

SPB (ISO 11819-1) [ISO22b]

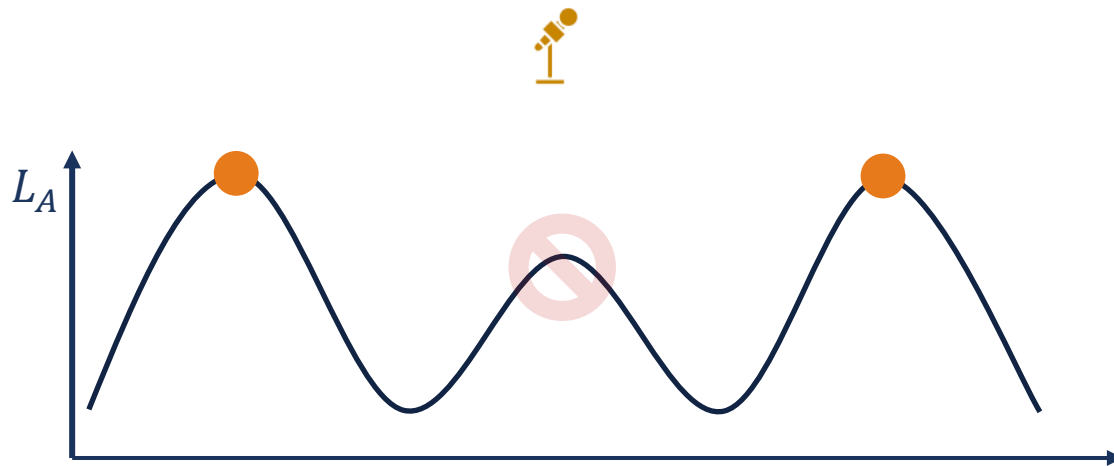
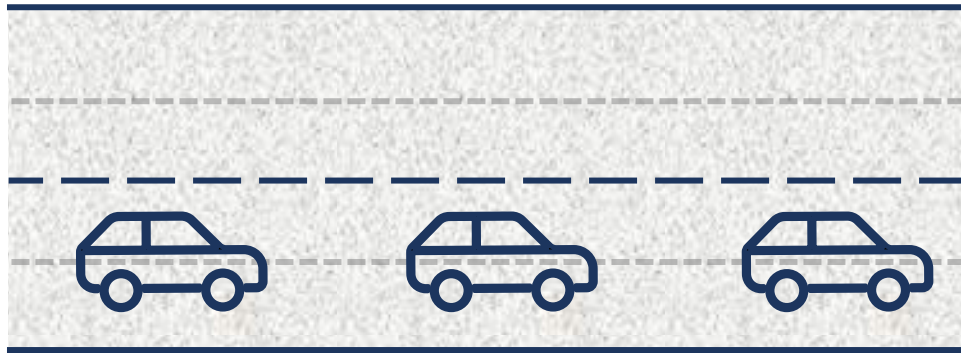

» Maximum sound pressure level $L_{A,max}$

Post-processing

- » L_{SPB} from measurements of several vehicles
- » Temperature correction (ISO/TS 1347-2)
- » Statistical pass by index (SPBI) can be calculated:

$$SPBI = 10 \log \left[W_P \times 10^{\frac{L_{SPB:P,v_{ref,P}}}{10}} + W_H \left(\frac{v_{ref,P}}{v_{ref,H}} \right) \times 10^{\frac{L_{SPB:H,v_{ref,H}}}{10}} \right]$$

Vehicle	Road 1		Road 2		Road 3	
	v_{ref} [km/h]	W	v_{ref} [km/h]	W	v_{ref} [km/h]	W
Cars (P)	50	0,9	80	0,8	110	0,7
Trucks (H)	50	0,1	80	0,2	80	0,3

- » **Project plan**
- » **Work Package 1 → Literature review**
 - » WP 1.1: Analysis of current source description models (END & CNOSSOS-EU)
 - » WP 1.2: Evaluation of noise mapping & management actions
- » **Work Package 2 → Elaboration of correction factors**
 - » WP 2.1: Analysis of existing source description methods
 - » WP 2.2: Determination of source description accuracy
 - » WP 2.3: Suitable adaptations of the source description
- » **Summary**
- » **Outlook**

- 1. Illustration of changes in noise maps over the past periods**
- 2. Overview of corresponding management plans**

Strategic noise maps (SNM)

- » Motivation: Evaluation of the effects of possibly erroneous calculations
- » Definition SNM: A graphical representation of expected/measured noise
- » Areas of application: Cities, roads, airports, and railroads (see **slide 51**)
- » Limiting values: No mandatory limiting values defined
- » For compliance with the environmental noise directive (END) 2002/49/EC:



- » Determination of exposure to environmental noise
- » Use of consistent calculation method (CNOSSOS) by all member states



- » Ensuring that the public is informed about environmental noise and its effects



- » Derivation of action plans from SNM: Prevention & reduction of environmental noise if necessary

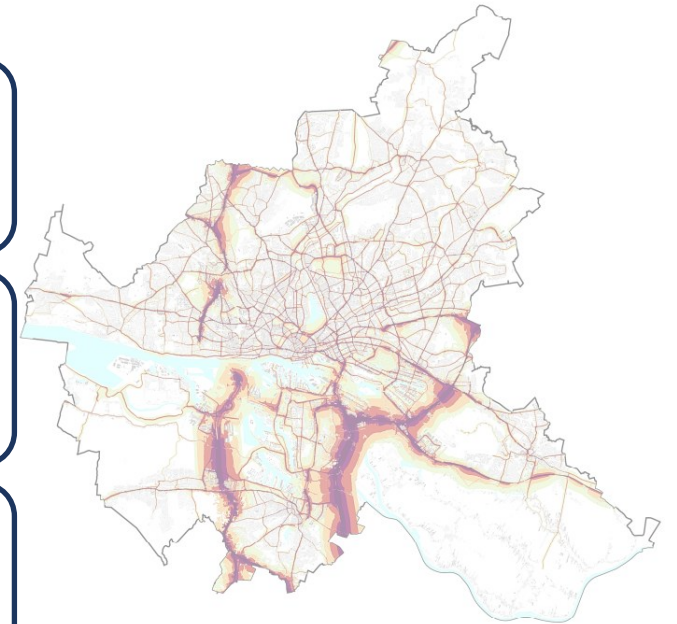





[EE23] [BU22]

General information on Strategic Noise Maps (SNM)

Regions for which Strategic Noise Maps must be created



-  Metropolitan areas with a population of >100k
-  Major roads with traffic volume >3 million vehicles per year
-  Major railway lines with traffic volume >30k trains per year
-  Major airports with traffic volume >50k movements per year

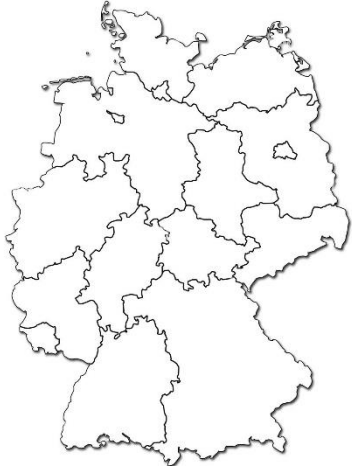

SNM can be published for whole federal states



SNM can be create only for mandatory areas

[AL23] [EE23] [EP20]

Overview of noise limits

- » No consistent limiting values for EU
- » Limiting values do exist on national level
- » Significant differences (see diagram below)

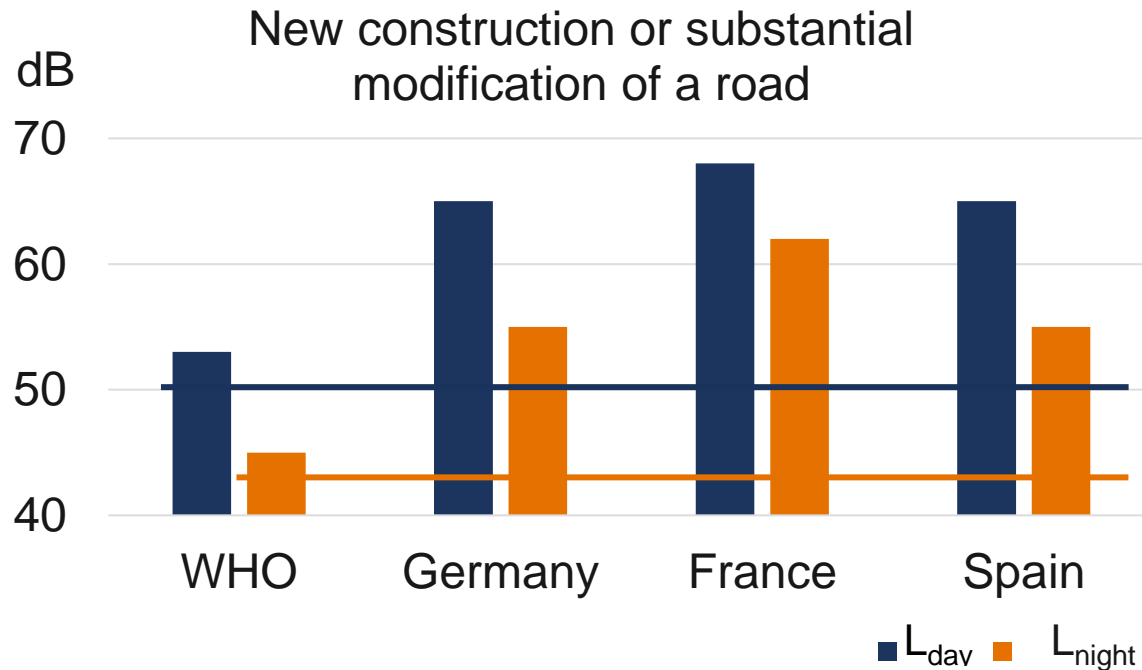

Creation of noise action plans

- » EU member states must ensure health of their inhabitants → Noise action plans
- » Noise action plans from European Environmental Agency as a guideline

List of possible mitigation measures:

- » Counter measures at the source (speed reduction)
- » Counter measures at the transfer path (noise barriers)
- » Urban planning (noise quality areas)
- » Infrastructural changes
- » Community engagement (counter measures for behavioral changes)

[WH18] [BR22] [UB22] [BC22] [EE20]

Detailed information for exemplary cities

Overview on biggest cities in EU

Country	City	Inhabitants	Population density (number per km ²)	Registered vehicles	SNM available?
Germany	Berlin	3.677.472	4.177	1.24 mill. (2022)	✓
Spain	Madrid	3.305.408	5.445	--	✓
Italy	Rome	2.761.632	2.149	1.6 mill. (2017)	✓
France	Paris	2.117.702	20.380	2.6 mill. (2021)	✓
Austria	Vienna	1.924.277	4.777	725.000 (2022)	✓
Germany	Hamburg	1.853.935	2.484	812.847 (2022)	✓
Poland	Warsaw	1.864.679	3.468	--	✓
Romania	Bucharest	1.716.983	7.980	1.5 mill. (2022)	✓
Hungary	Budapest	1.706.851	3.251	690.560 (2022)	✓
Spain	Barcelona	1.636.732	16.367	--	✓

Note: Inhabitants within the city administrative boundaries, not urban areas, as their size differ significantly.

Detailed information on Berlin, Madrid and Paris on the following slides (54-62)

[CI22] [ST22a] [ST22b] [ST22c] [ST22d] [EU23] [KS22] [IN22a] [IN22b] [IS22]

Detailed information for exemplary cities – Berlin

Strategic Noise Maps over the last years

2007



2012

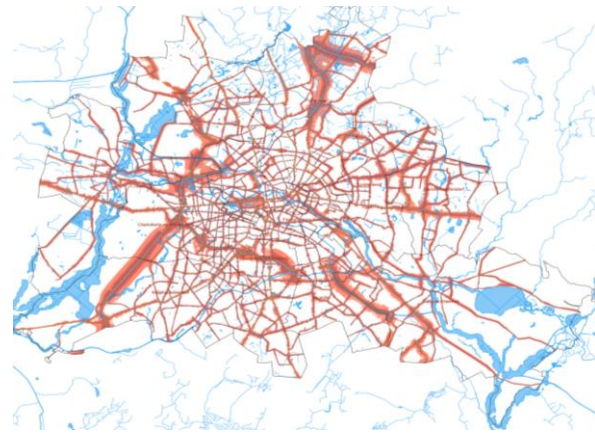

- » SNM already derived before 2007 (before mandatory in the EU)
- » Not considered here due to lack of comparability (different calculation methods)

- » **Interim calculation method introduced for comparability called VBUS**
 - » VBUS: Preliminary calculation method for Road Environmental Noise
 - » L_{DEN} as a function of weighted L_{Day} , $L_{Evening}$ and L_{Night}
 - » Differences based on different software versions
- » **The new SNM for the fourth round (2022) isn't published yet**

2017



New software version

[BU17]

Detailed information for exemplary cities – Berlin

Counter measures resulting from the Strategic Noise Maps

» In general:

- » Existing roads: No regulation → no legal entitlement to noise remediation
- » Renewed/new road: Depicted noise values must be considered (acc. to German environment agency)

» SNM in 2007: Redesign of roads to minimise noise emissions

- » Road types affected: Two lines in each direction and traffic volume >20.000 vehicles per day
- » Measure: Lane for bicycles

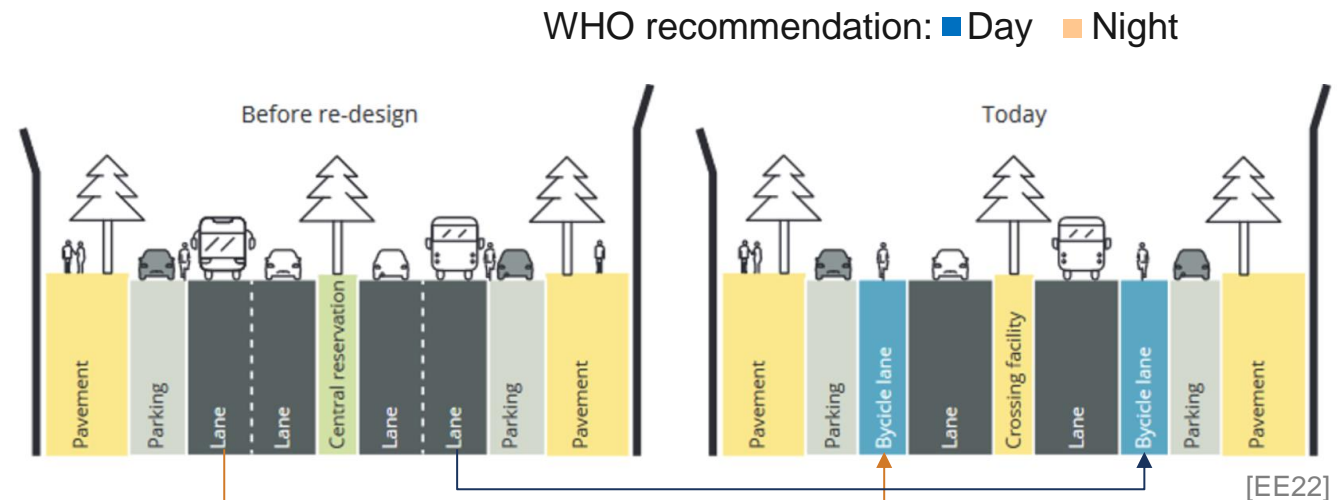
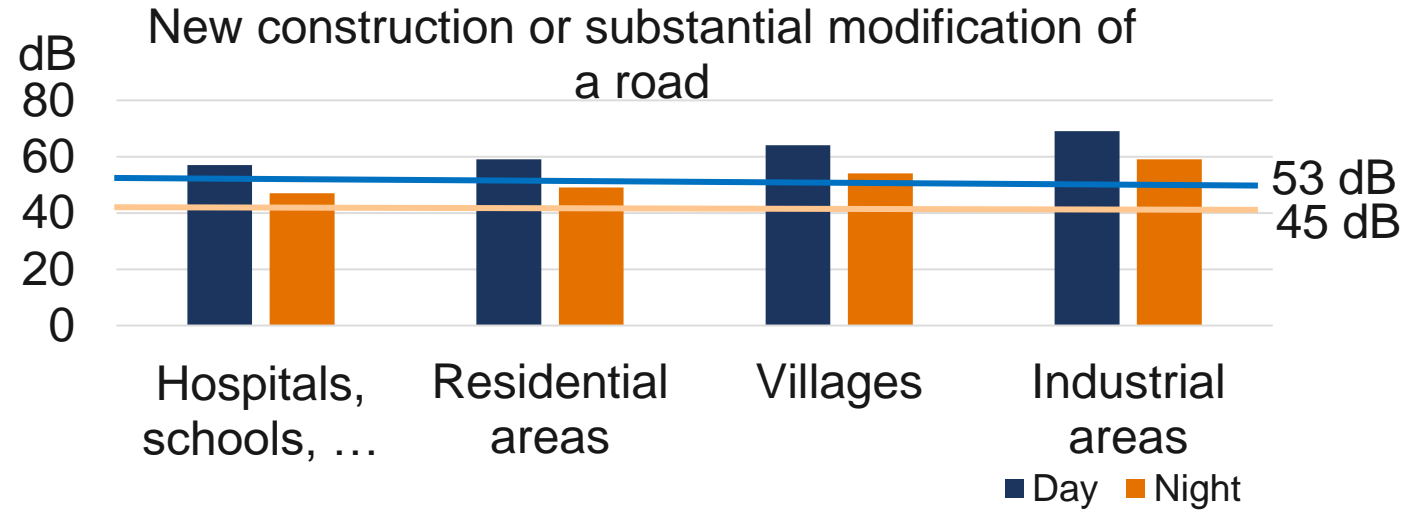

Detailed information for exemplary cities – Madrid

Strategic Noise Maps over the last years

2007

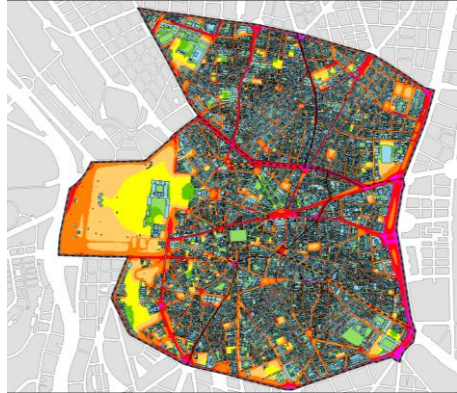

2012

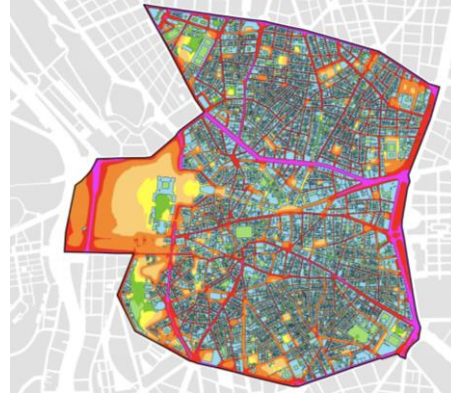

More measurement positions

2007 & 2012

- » SNM were created according to districts
- » Differences between these years are mainly based on the expansion of the measurement positions

- » 2017: Calculation method changed (counting light and heavy vehicles)
- » 2022: first year CNOSSOS was used
 - » Lower noise levels are caused by the new calculation method

2017



2022



CNOSSOS was used

[TP23]

Detailed information for exemplary cities – Madrid

Used Calculation Methods

- » **2007 & 2012 SNM in Madrid were based on direct measurements**
 - » 4395 measuring points
 - » Using SADMAN software for data collection & SNM generation
 - » High costs for such measurement procedure, mainly due to maintenance of the measuring points
- » **2017: SNM based on vehicles counts**
 - » Differentiation between heavy and light vehicles
- » **2022: SNM based on CNOSSOS**
 - » Significant noise reduction between 2017 & 2022 due to CNOSSOS-EU (4 different vehicle categories)



[TP23]

Detailed information for exemplary cities – Madrid

Counter measures resulting from the Strategic Noise Maps

- » **Counter measures & preparation of 4th Round (2022) of SNM characterised by the following factors:**
 1. Implementation CNOSSOS calculation method
 2. Restriction on hours of operation (roadworks, public outdoor events/festivals, ...)
 3. Promotion of public transport

- » **Significant decrease in noise levels between 2012 & 2017**
 - » Number of people exposed to high noise levels decreased by 47% during the day and by 38% at night

- » **This is mainly due to the following counter measures:**
 - » Reduction of traffic intensity
 - » New pedestrian zones
 - » Promotion of public transport
 - » Sound absorbing asphalt

	People exposed to high noise levels [%]		Reduction from 2012 to 2017 [%]
	In 2012	In 2017	
L_{day}	4,1	2,2	46,7
$L_{evening}$	2,9	1,6	46,4
L_{night}	14,9	9,3	37,9

[TP23]

Detailed information for exemplary cities – Paris

Strategic Noise Maps over the last years



2007 - 2012

- » ~70% of the inhabitant's are affected by high noise levels (acc. to WHO recommendation)
 - » Consequently Paris has a far-reaching noise action plan to reduce these noise levels

- » France provides interactive SNM
 - » Increase of clarity and accessibility to the public



2017

[BR17]

Detailed information for exemplary cities – Paris

Counter measures resulting from the Strategic Noise Maps

» In 2022, 79 % of residents are bothered by noise

» Main source for noise pollution: Road traffic

» Previous noise action plan 2015-2020:

» Reduction of noise by ~2 dB

» Current noise action plan 2021-2026:

» Aim: ~2% per year overall decrease due to 34 counter measures

» Counter measure categories:

1. Environmental noise: traffic noise, asphalt quality, noise from commercial facilities
2. Neighbourhood noise: restaurants, public outdoor events/festivals, hours for roadworks/road cleaning, sound emissions of rubbish trucks/street sweepers, ...

» Major counter measures:

- » Speed limit of 30 km/h except for ring road (70 km/h) and some major roads (50 km/h)
- » Extension of bicycle lanes

21% Undisturbed
by noise

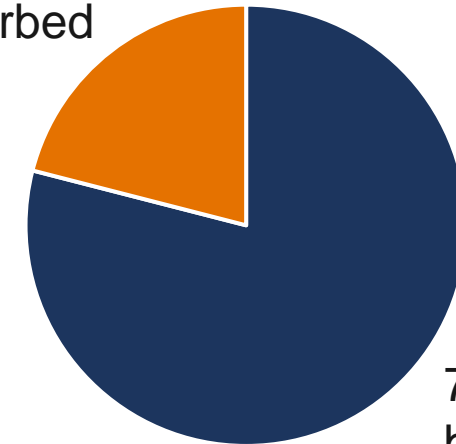

79% Bothered
by noise

Detailed information for exemplary cities – Paris

Counter measures resulting from the Strategic Noise Maps

- » 79 % of residents are bothered by noise
- » Main source for noise pollution: Road traffic
- » Previous noise action plan 2015-2020:
 - » Reduction of noise by ~2 dB

- » **Current noise action plan 2021-2026:**
 - » Aim: ~2% per year overall decrease due to 34 counter measures

- » Counter measure categories:

1. Environmental noise: traffic noise, asphalt quality, noise from commercial facilities
2. Neighbourhood noise: cleaning, maintenance, construction, etc.

- » Major counter measures:

- » Speed limits
- » Extension of low-noise zones

Question/remark: Is that in conflict with the zero pollution action plan?

Question/remark: Is this value correct?

21% Undisturbed by noise

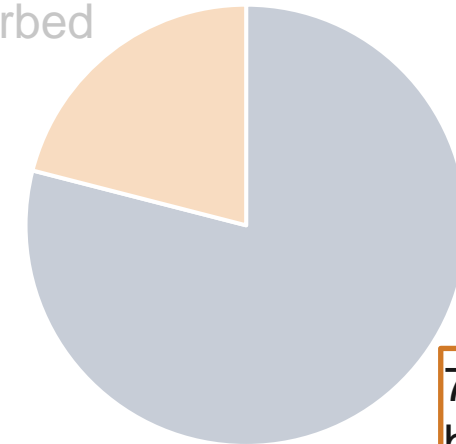

79% Bothered by noise

[PAR22] [BRU19]

Noise reduction in Paris

The quality of the capital's sound environment is improving due in particular to:

- The generalization of the speed limit to 30 km/h on all Parisian roads (except the ring road at 70 km/h and some major axes maintained at 50 km/h),
- The overall reduction in road traffic in Paris, of approximately 2% per year on the instrumented network, due in particular to the extension of the lanes reserved for bicycles.

» Here:

- » Result of the previous noise action plan in Paris (PPBE 2015 – 2020) → 2% reduction of road traffic flow
- » EU action plan towards zero pollution:
 - » Reduction of people chronically disturbed by transport noise by 30%

Impact of road traffic on noise pollution

- » Main source of noise pollution in outdoor environment in Île-de-France: road traffic
 - » It is responsible for 79% of people potentially exposed to noise limit values being exceeded

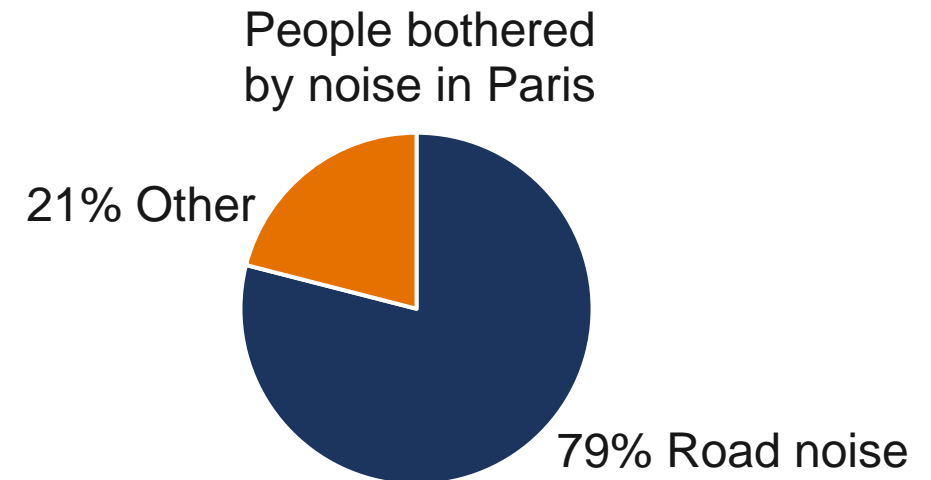

[PAR22] [EUR22] [BRU15] [BRU17] [BRU22] [CEN19]



So far, every country used different & varying calculation methods to create SNM → No comparability
→ Introduction of CNOSSOS-EU



The level of publication isn't regulated: Every member state can publish their SNM on a country-, federal state-, city-, ... basis



The counter measures to reduce noise differ significantly. There is no procedure specified for the derivation of counter measures from SNM, however, the member states must ensure the health of their citizens

- » **Project plan**
- » **Work Package 1 → Literature review**
 - » WP 1.1: Analysis of current source description models (END & CNOSSOS-EU)
 - » WP 1.2: Evaluation of noise mapping & management actions
- » **Work Package 2 → Elaboration of correction factors**
 - » WP 2.1: Analysis of existing source description methods
 - » WP 2.2: Determination of source description accuracy
 - » WP 2.3: Suitable adaptations of the source description
- » **Summary**
- » **Outlook**

- » **Project plan**
- » **Work Package 1 → Literature review**
 - » WP 1.1: Analysis of current source description models (END & CNOSSOS-EU)
 - » WP 1.2: Evaluation of noise mapping & management actions
- » **Work Package 2 → Elaboration of correction factors**
 - » WP 2.1: Analysis of existing source description methods
 - » WP 2.2: Determination of source description accuracy
 - » WP 2.3: Suitable adaptations of the source description
- » **Summary**
- » **Outlook**

Analysis of existing source description methods

Key questions/ tasks within work package 2.1

1. Detailed analysis on CNOSSOS & HARMONOISE/IMAGINE
2. Summary of technical achievements that are considered in the respective source description models

CNOSSOS-EU

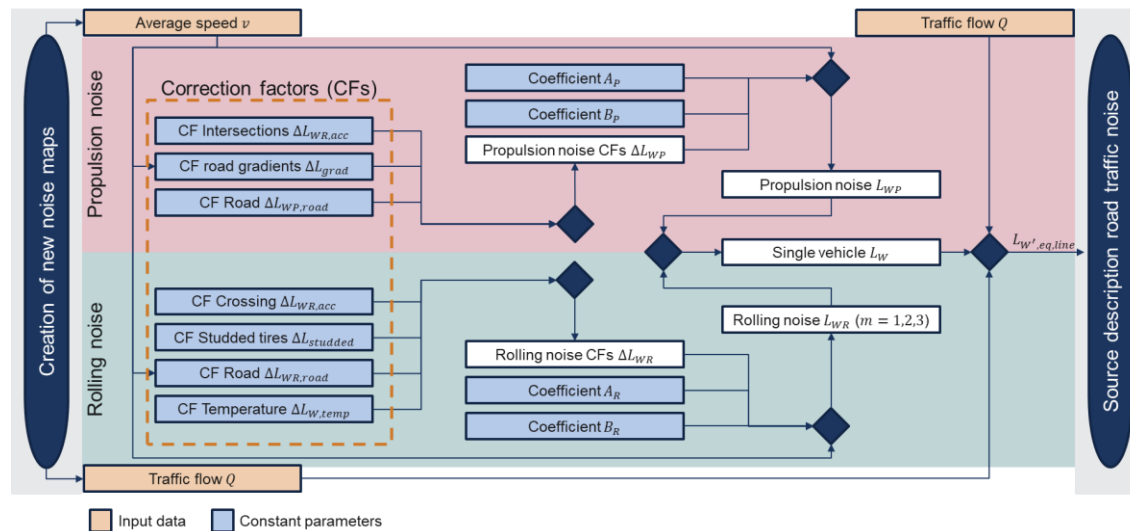

HARMONOISE/IMAGINE

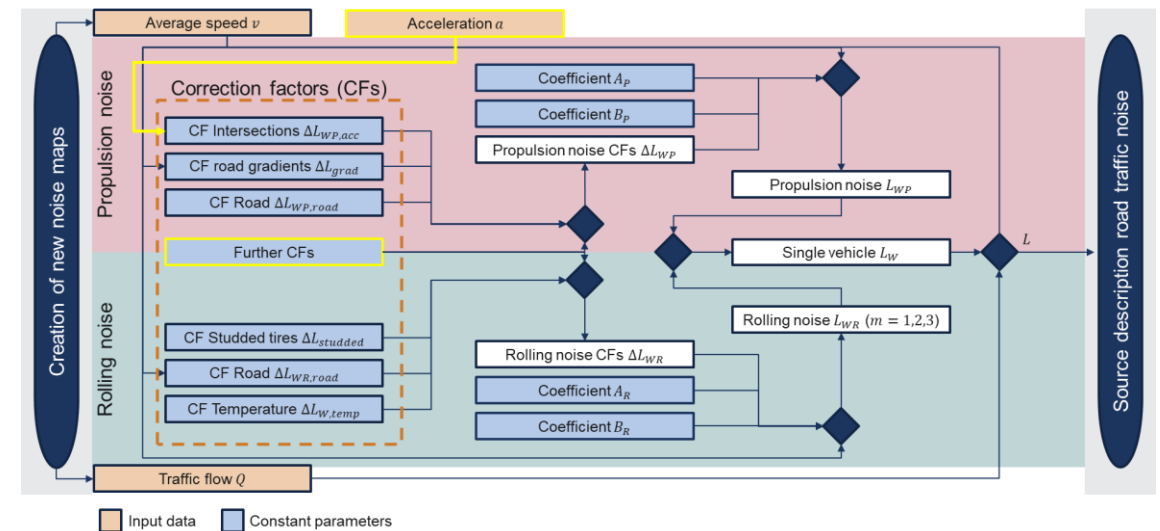

Detailed Analysis on CNOSSOS-EU & HARMONOISE/ IMAGINE

Flow chart for CNOSSOS-EU (from slide 13)

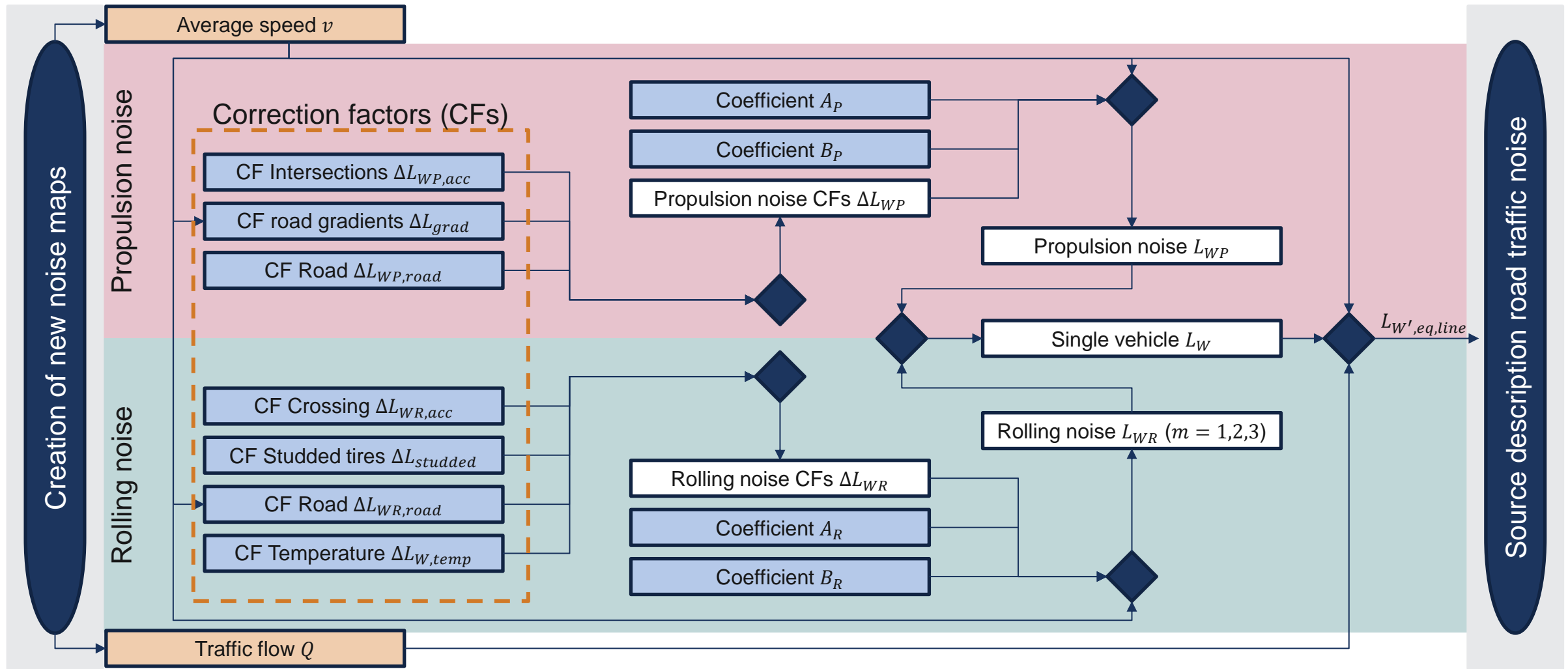

Note: For reasons of clarity, the dependence on frequency (octave band) and vehicle category is not shown

Input data Constant parameters

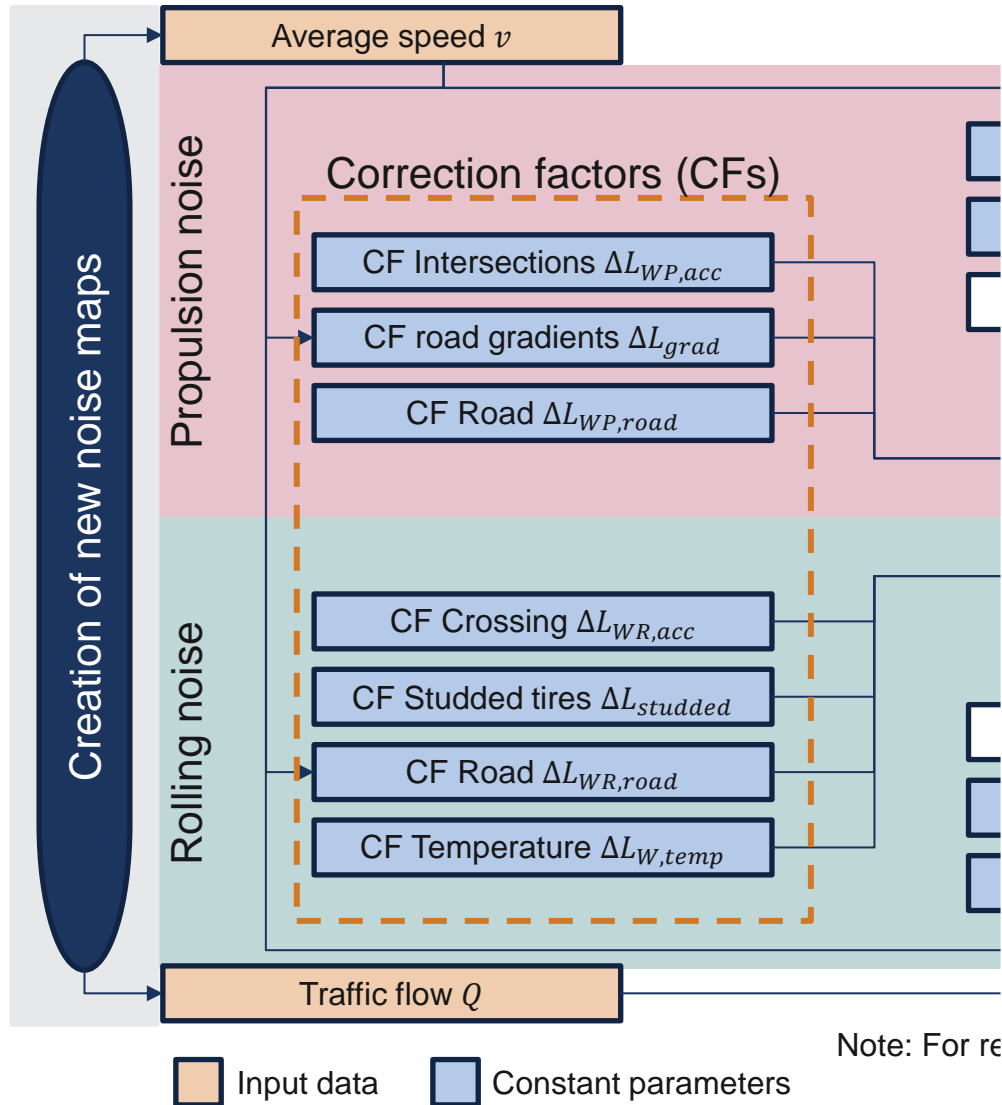

CNOSSOS-EU vehicle sound source description [EUR15]

» Noise emission as a function of vehicle speed and frequency (equation based)

» Rolling noise

$$L_{WR} = A_R + B_R \cdot \log\left(\frac{v}{v_{ref}}\right) + \Delta L_{WR}$$

» Propulsion noise

$$L_{WP} = A_P + B_P \cdot \frac{v - v_{ref}}{v_{ref}} + \Delta L_{WP}$$

» Overall sound level

$$L_W = 10 \cdot \log(10^{0.1L_{WR}} + 10^{0.1L_{WP}})$$

» $v_{ref} = 70$ kph

» Correction factors (CFs)

Question: Why is the reference speed for CNOSSOS-EU 70 kph?

Reference speed in HARMONOISE reports

- » In CNOSSOS-EU no reason is given why 70 km/h is chosen
 - » It was used from HARMONOISE onwards
- » [JON06] regarding HARMONOISE model:
„Another problem to consider for predictions is the integration time at short distances. [...] We can see that time-weighting F is too slow to yield the true maximum level above about 30 km/h. However, if we select 70 or 80 km/h as reference speed the error will be within +0,3 dB which is quite acceptable for the short distance of 6,75 m. For longer distances this effect will decrease and can thus be disregarded.”
 - » 6.75m corresponds to the distance from the wheels to the SPB microphone

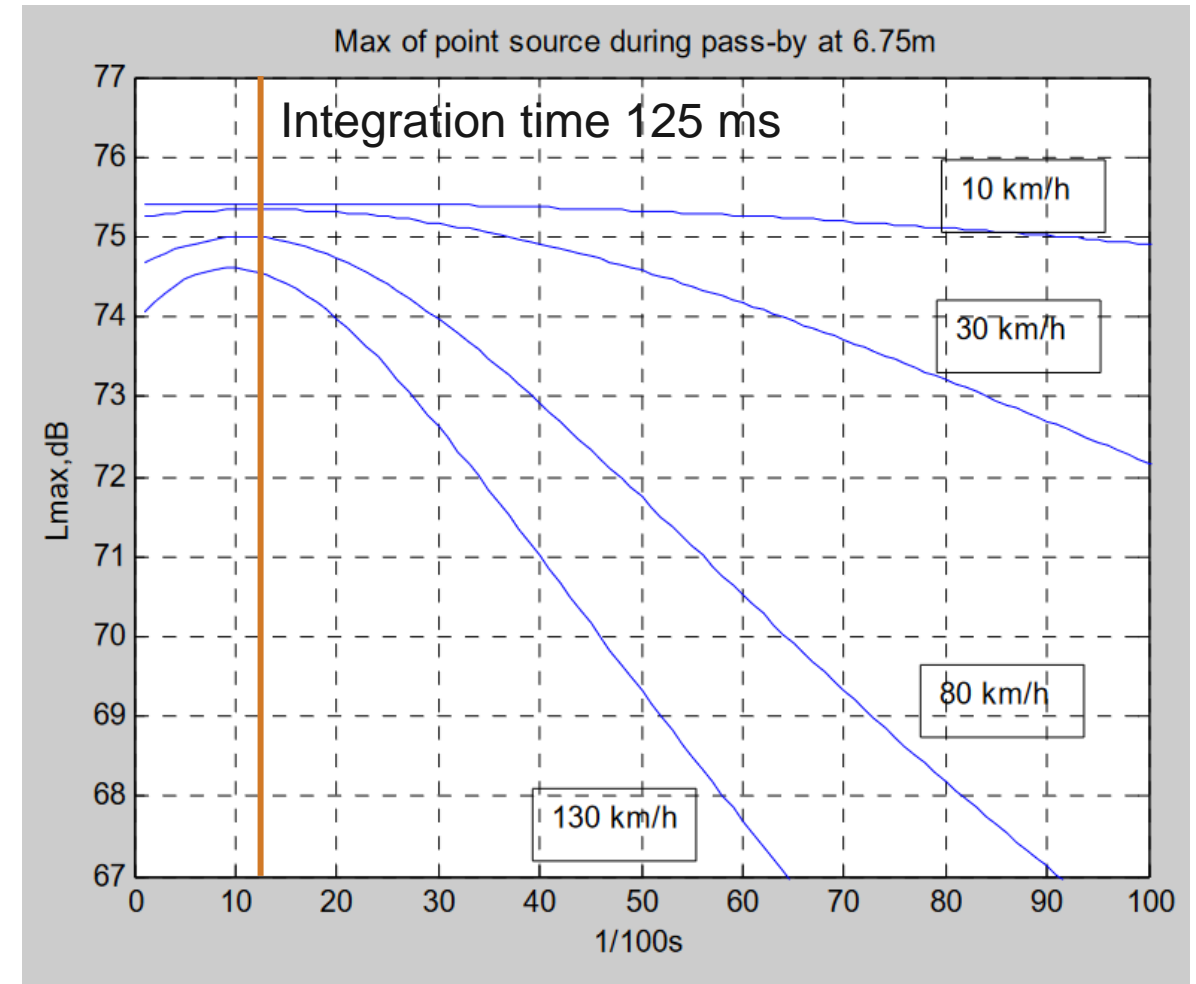

[JON06]

Reference speed in HARMONOISE reports

- » In CNOSSOS-EU no reason is given why 70 km/h is chosen
 - » It was used from HARMONOISE onwards
- » [JON06] regarding HARMONOISE model:
„Another problem to consider for predictions is the integration time at short distances. [...] We can see that time-weighting F is too slow to yield the true maximum level above about 30 km/h. However, if we select 70 or 80 km/h as reference speed the error will be within +0,3 dB which is quite acceptable for the short distance of 6,75 m. For longer distances this effect will decrease and can thus be disregarded.”
 - » 6.75m corresponds to the distance from the wheels to the SPB microphone

Reference speed – Analysis

- » One difficulty for choosing the reference speed was the short distance between source (vehicle) and receiver (microphone) during measurements
- » This means that a reference speed above 30 km/h but below 70 km/h would have led to a higher error in prediction while using with time-weighting F
- » Higher speeds (like 70 km/h) lead to an smaller error of less than 0.5 dB which was considered acceptable during HARMONOISE

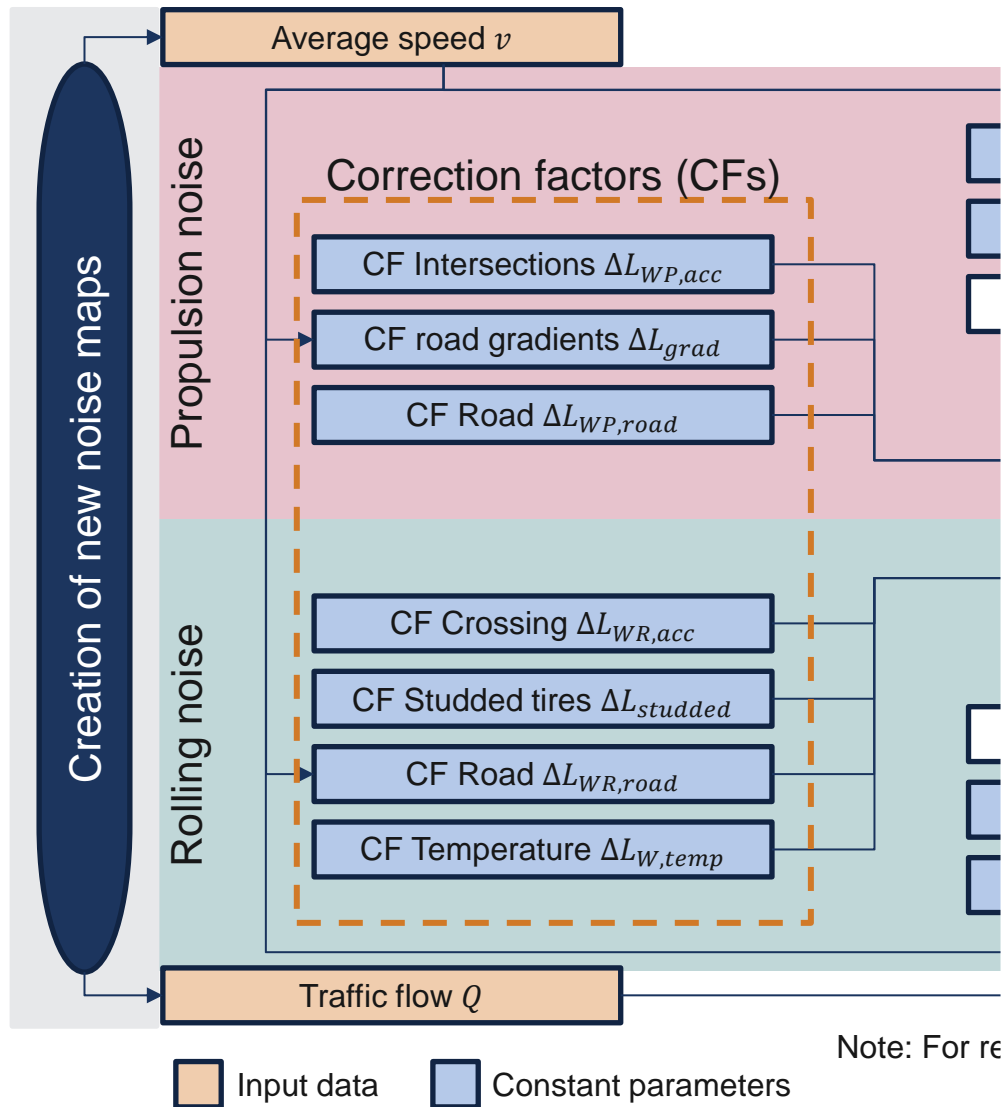

CNOSSOS-EU vehicle sound source description [EUR15]

» Noise emission as a function of vehicle speed and frequency (equation based)

» Rolling noise

$$L_{WR} = A_R + B_R \cdot \log\left(\frac{v}{v_{ref}}\right) + \Delta L_{WR}$$

» Propulsion noise

$$L_{WP} = A_P + B_P \cdot \frac{v - v_{ref}}{v_{ref}} + \Delta L_{WP}$$

» Overall sound level

$$L_W = 10 \cdot \log(10^{0.1L_{WR}} + 10^{0.1L_{WP}})$$

» $v_{ref} = 70$ kph

» Correction factors (CFs)

Question: How are the coefficients A_R, B_R, A_P, B_P derived?

Directivity – HARMONOISE – State of the art

- » Not much data available on frequency dependency
- » Accurate source modelling requires directivity due to:
 1. Horn effect (amplification due to geometry)
 2. Acoustic shielding by the vehicle itself
- » General characteristics of vertical directivity:
 - » Only small directivity $0^\circ - 45^\circ$
 - » $>45^\circ$ decrease by 5 dB
- » General characteristics of horizontal directivity:
 - » Perpendicular to the road lowest radiation due to horn effect (not depicted due to low vehicle speed of 40 km/h)
 - » At $\sim 45^\circ$ increase by 3-5 dB
 - » Slightly higher radiation in backward direction

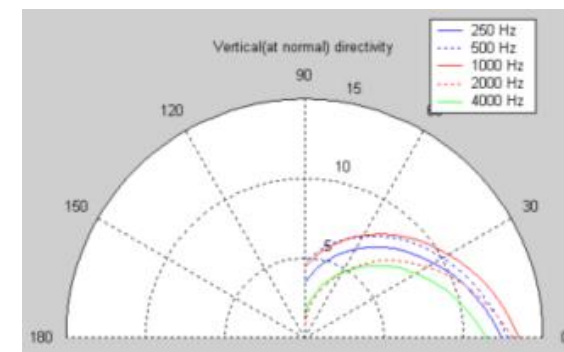
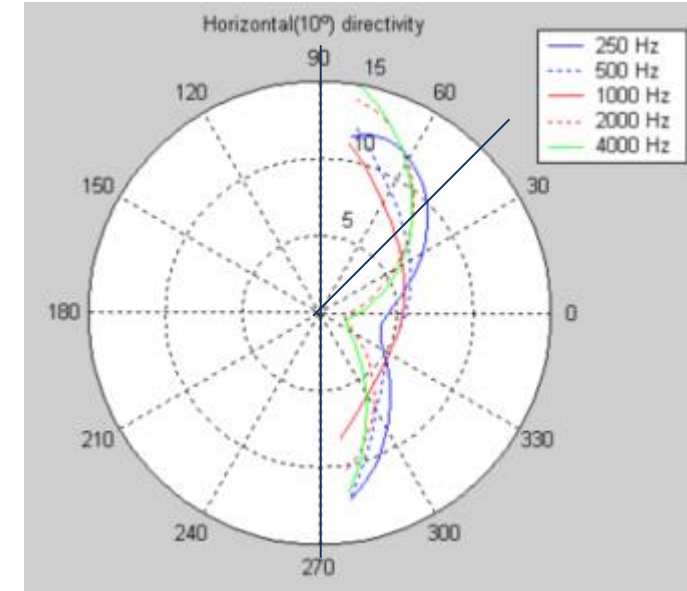

[JON04]

Directivity – HARMONOISE

- » Vertical directivity:
 - » All point sources: frequency dependent (vehicle shielding)
- » Horizontal directivity:
 - » Lowest point source: frequency dependent (rolling noise horn effect)
 - » Highest point source: frequency independent (propulsion noise)
- » Directivity function:
 - » $\Delta L(f, \varphi, \psi) = \Delta L_H(f, \varphi) + \Delta L_V(f, \psi)$

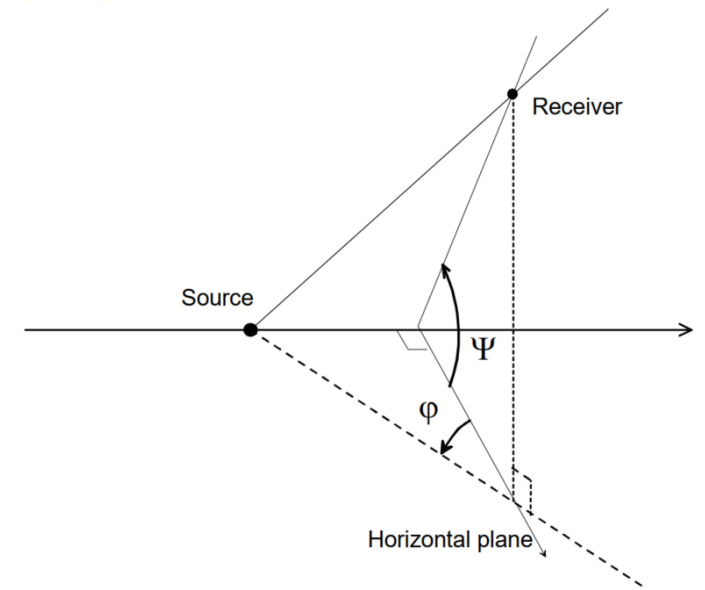
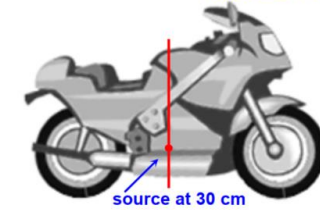
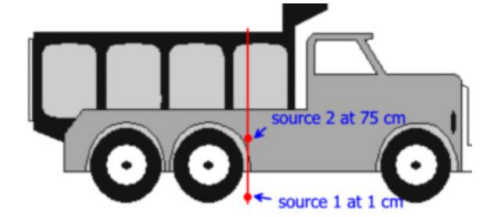
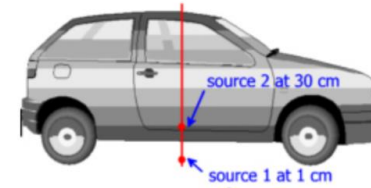

[JON04] [IMA07]

Directivity – HARMONOISE – Vertical

- » Measurement setup by Autostrade:
 - » At night on public streets
 - » On one lane of a motor way (other lanes blocked)
 - » 5 microphones (arc with 7.5m)

- » Derivation of directivity for HARMONOISE:
 - » These measured curves were approximated by means of functions
 - » For easier use: no differentiation of vehicle category

Measured

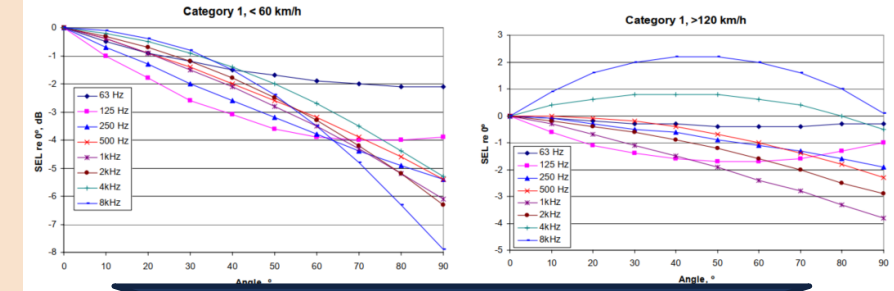

Approximation

Frequency, category & height

	Cat 1 $h_s=0,3m$	Cat 1 $h_s=0,01m$	$h_s=0,01m$	Cat 2 $h_s=0,75m$	Cat 3 $h_s=0,01m$	Cat 3 $h_s=0,75m$
50,63,80	$-2\sin(\psi)$	0	0	0	0	0
100,125,160	$-4\sin(\psi)$	$-2\sin(\psi)$	0	0	0	0
200,250,315	$-5(1-\cos^2(\psi))$	$-2(1-\cos^2(\psi))$	$-2(1-\cos^2(\psi))$	$-2(1-\cos^2(\psi))$	$-4(1-\cos^2(\psi))$	$-2(1-\cos^2(\psi))$
400,500,630	$-5(1-\cos^2(\psi))$	$-2(1-\cos^2(\psi))$	$-3(1-\cos^2(\psi))$	$-3(1-\cos^2(\psi))$	$-5(1-\cos^2(\psi))$	$-3(1-\cos^2(\psi))$
800,1000,1250	$-6(1-\cos^2(\psi))$	$-3(1-\cos^2(\psi))$	$-3(1-\cos^2(\psi))$	$-3(1-\cos^2(\psi))$	$-5(1-\cos^2(\psi))$	$-3(1-\cos^2(\psi))$
1600,2000,2500	$-6(1-\cos^2(\psi))$	$-4(1-\cos^2(\psi))$	$-2(1-\cos^2(\psi))$	$-2(1-\cos^2(\psi))$	$-4(1-\cos^2(\psi))$	$-2(1-\cos^2(\psi))$
3150,4000,5000	$-5(1-\cos^2(\psi))$	0	$-2(1-\cos(\psi))$	$-2(1-\cos(\psi))$	$-4(1-\cos(\psi))$	$-2(1-\cos(\psi))$
6300,8000,10000	$-8(1-\cos(\psi))$	0	$-2(1-\cos(\psi))$	$-2(1-\cos(\psi))$	$-4(1-\cos(\psi))$	$-2(1-\cos(\psi))$

Simplification

Frequency & height

Freq./source height	$h_s=0,01m$	$h_s=0,3m$	$h_s=0,75m$
50,63,80	0	$-2\sin(\psi)$	0
100,125,160	0	$-4\sin(\psi)$	0
200,250,315	$-2(1-\cos^2(\psi))$	$-5(1-\cos^2(\psi))$	$-2(1-\cos^2(\psi))$
400,500,630	$-3(1-\cos^2(\psi))$	$-5(1-\cos^2(\psi))$	$-3(1-\cos^2(\psi))$
800,1000,1250	$-4(1-\cos^2(\psi))$	$-6(1-\cos^2(\psi))$	$-3(1-\cos^2(\psi))$
1600,2000,2500	$-4(1-\cos^2(\psi))$	$-6(1-\cos^2(\psi))$	$-2(1-\cos^2(\psi))$
3150,4000,5000	0	$-5(1-\cos^2(\psi))$	$-2(1-\cos(\psi))$
6300,8000,10000	0	$-8(1-\cos(\psi))$	$-2(1-\cos(\psi))$

[JON04]

Directivity – HARMONOISE – Horizontal

- » Various measurement have been considered, e.g.:
 - » Pass by measurements on public streets (Autostrade)
 - » 5 microphones in an half-sphere (1.2 m)
- » Source height 0.01 m (accounting for horn effect):
 - » $\Delta L_H(f, \varphi) = 0 \quad (f \leq 1250 \text{ Hz} \ \& \ f > 8000 \text{ Hz})$
 - » $\Delta L_H(f, \varphi)$: dependent on φ and ψ ($1600 \leq f \leq 6300 \text{ Hz}$)
- » Source height 0.3 m (propulsion):
 - » $\Delta L_H(f, \varphi) = 0$
- » Source height 0,75 m (propulsion):
 - » $\Delta L_H(f, \varphi)$: dependent on φ and ψ
- » Factor $\sqrt{\cos(\psi)}$ is included to avoid computational issues
 - » ψ is not defined on top of the car
 - » $\cos(\psi)$ decreases the influence close to horizontal plane

Measured

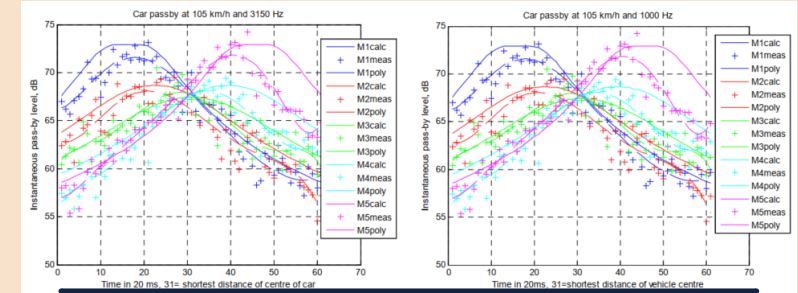

Approximation

“The conclusions are not obvious.”

Simplification

Frequency & height

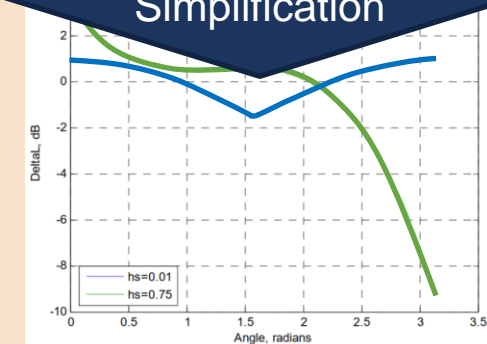

[JON04]

Directivity – IMAGINE

- » In IMAGINE it is referred to HARMONOISE for detailed information
- » However, due to high complexity, the functions are simplified:
 1. Neglecting of horizontal directivity
 - » Since no impact on L_{eq} (equivalent sound pressure level)
 - » But: Consideration for L_{max} (max. sound pressure level)
 2. No frequency dependence for vertical directivity
 - » Category 1: $\Delta L(\psi) = -\frac{\psi}{20^\circ} [dB] \rightarrow 90^\circ \triangleq -4.5 \text{ dB}$
 - » Category 2&3: $\Delta L(\psi) = -\frac{\psi}{30^\circ} [dB] \rightarrow 90^\circ \triangleq -3 \text{ dB}$
 - » Note: Significant deviation expected for low frequencies

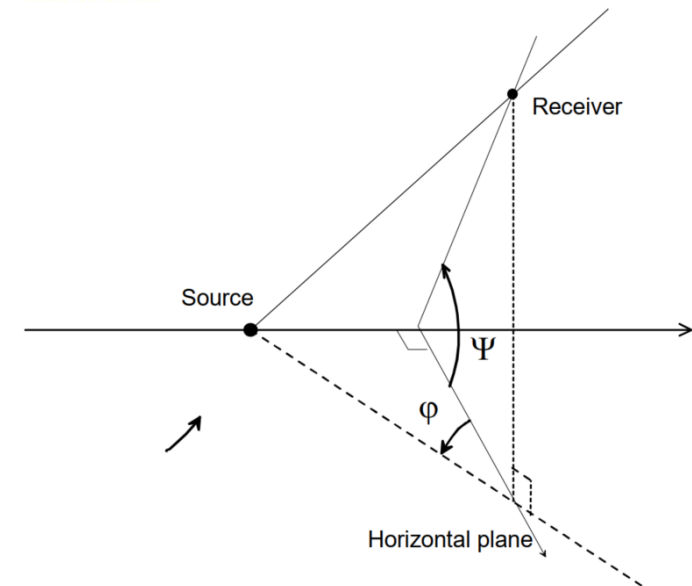
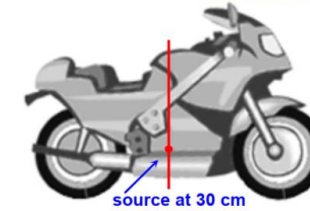
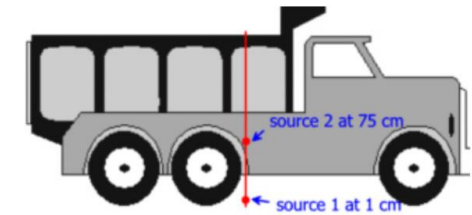
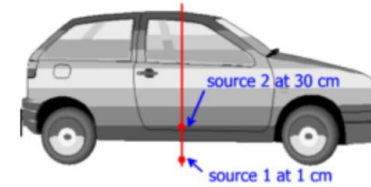

[IMA07]

Directivity – CNOSSOS-EU

- » Very little information in the current directive [EU15]:
 - » “ $L_{W,i,m}$ is the directional sound power of a single vehicle”
 - » “each vehicle [...] is represented by one single point source radiating uniformly into the $2\text{-}\pi$ half space”
- » However, in a draft document it is stated [EUR11]:
 - » “For noise mapping purposes, road vehicles can be reasonably modelled as omnidirectional point sources”
 - » “in specific cases such as the determination of sound power levels from vehicle pass-by measurements, [...] the point sources should be assigned both horizontal and vertical directivity”

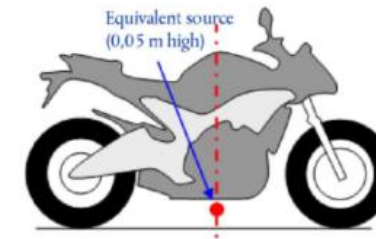
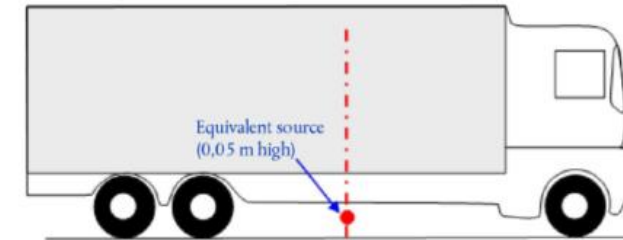
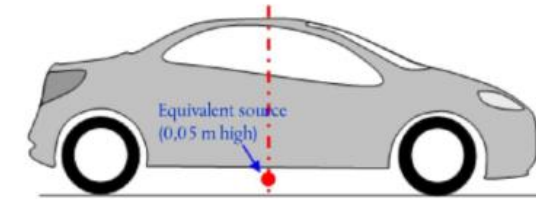

[EUR11] [EU15]

Directivity – CNOSSOS-EU

- » Overall directivity correction [EUR11]
 - » $\Delta L_{W,dir} = \Delta L_{W,dir,hor} + \Delta L_{W,dir,vert}$
- » Horizontal directivity can be neglected for road vehicles
- » Vertical directivity is the same as in IMAGINE
 - » Category 1: $\Delta L_{W,dir} = -\frac{9\psi}{\pi}$ [dB] $\rightarrow \frac{\pi}{2} \triangleq -4.5$ dB
 - » Category 2&3: $\Delta L_{W,dir} = -\frac{6\psi}{\pi}$ [dB] $\rightarrow \frac{\pi}{2} \triangleq -3$ dB
- » Again:
 - » No directivity effect is defined for category 4 (two-wheelers)
 - » For low frequencies strong deviations expected due to interference
- Were the coefficients determined using this approach?

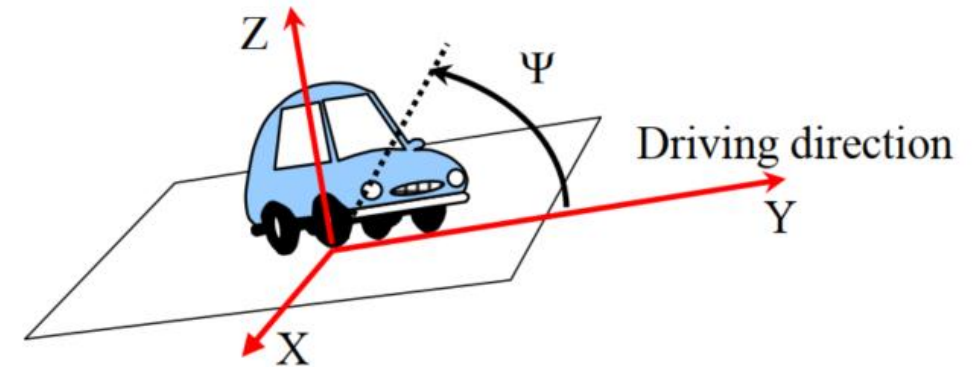

[EUR11]

Information from [EUR11] & [EUR15]

- » First draft for CNOSSOS-EU [EUR11]:
 - » An empty appendix is included regarding the procedure to derive the coefficients
 - » “To be inserted (from Harmonoise/Imagine report)”
- » Final directive [EUR15]:
 - » No information on derivation of coefficients

Draft [EUR11]:

Appendix III-B – Procedure applied to derive reference coefficients for sound power emission of road vehicles

To be inserted (from Harmonoise/Imagine report)

Further editing

Final directive [EUR15]:

No information on the procedure of the coefficient derivation included

[EUR11] [EU15] [PEE18]

Detailed Analysis on CNOSSOS-EU & HARMONOISE/IMAGINE

Sound power coefficients – Derivation from measurements

Information from [PEE18]

- » Publication regarding coefficient correction [PEE18]:
 - » Coefficients used in CNOSSOS-EU have been derived in IMAGINE
 - » Only difference: octave (CNOSSOS-EU) vs 1/3 octave (HARMONOISE/IMAGINE)
 - » Resulting deviation due to differences in propagation models

IMAGINE coefficients [IMA07b]

		frequency [Hz]											
		25	31,5	40	50	63	80	100	125	160	200	250	315
cat.1 <i>light motor vehicles</i>	A_R	69,9	69,9	69,9	74,9	74,9	74,9	79,3	82,0	81,2	80,9	78,9	78,8
	B_R	33,0	33,0	33,0	30,0	30,0	30,0	41,0	41,2	42,3	41,8	38,6	35,5
	A_P	87,0	87,0	87,0	87,9	90,8	89,9	86,9	82,6	81,9	82,3	83,9	83,3
	B_P	0,0	0,0	0,0	0,0	-3,0	0,0	8,0	6,0	6,0	7,0	8,0	8,0
	C_P	4,0	4,0	4,0	7,0	7,0	7,0	7,0	7,0	7,0	7,0	4,0	4,0
cat.2 <i>medium heavy vehicles</i>	A_R	76,5	76,5	76,5	78,5	79,5	79,5	82,5	84,3	84,7	84,3	87,4	87,8
	B_R	33,0	33,0	33,0	30,0	30,0	30,0	32,9	35,9	38,1	36,5	33,5	30,6



CNOSSOS-EU coefficients [EUR15]

Coefficients $A_{R,L,m}$ and $B_{R,L,m}$ for rolling noise and $A_{P,L,m}$ and $B_{P,L,m}$ for propulsion noise									
Category	Coefficient	63	125	250	500	1 000	2 000	4 000	8 000
1	A_R	79,7	85,7	84,5	90,2	97,3	93,9	84,1	74,3
	B_R	30	41,5	38,9	25,7	32,5	37,2	39	40
	A_P	94,5	89,2	88	85,9	84,2	86,9	83,3	76,1
	B_P	- 1,3	7,2	7,7	8	8	8	8	8
	A_R	84					90,9	83,8	

[EU15] [IMA07B]

Detailed Analysis on CNOSSOS-EU & HARMONOISE/ IMAGINE

Sound power coefficients – CNOSSOS-EU Revision – Background

CNOSSOS-EU revision [EUR21]

CNOSSOS-EU has been updated in 2021 with [EUR21]

- » Adaptions were made for, e.g.
 - » Correction factors
 - » Sound power coefficients

CNOSSOS-EU coefficients “initial” [EUR15]

Coefficients $A_{R,L,m}$ and $B_{R,L,m}$ for rolling noise and $A_{P,L,m}$ and $B_{P,L,m}$ for propulsion noise

Category	Coefficient	63	125	250	500	1 000	2 000	4 000	8 000
1	A_R	79,7	85,7	84,5	90,2	97,3	93,9	84,1	74,3
	B_R	30	41,5	38,9	25,7	32,5	37,2	39	40
	A_P	94,5	89,2	88	85,9	84,2	86,9	83,3	76,1
	B_P	- 1,3	7,2	7,7	8	8	8	8	8
	A_R	84					90,9	83,8	



CNOSSOS-EU coefficients “revised” [EUR21]

(a) Table F-1 is replaced by the following:

Category	Coefficient	63	125	250	500	1 000	2 000	4 000	8 000
1	A_R	83,1	89,2	87,7	93,1	100,1	96,7	86,8	76,2
	B_R	30,0	41,5	38,9	25,7	32,5	37,2	39,0	40,0
	A_P	97,9	92,5	90,7	87,2	84,7	88,0	84,4	77,1
	B_P	-1,3	7,2	7,7	8,0	8,0	8,0	8,0	8,0
2	A_R	88,7	93,2	95,7	100,9	101,7	95,1	87,8	83,6
	B_R	30,0	35,8	35,8	25,7	30,1	36,2	36,2	40,0

[EU15] [EUR21]

Coefficients [EUR15], [EUR21] & [IMA07b]

- » Speed-independent rolling coefficients
- » Note: CNOSSOS octave and IMAGINE 1/3 octave
- » Key messages:
 - » Summing the 1/3 octaves from IMAGINE results in the initial CNOSSOS coefficients
 - » Only for 250 Hz and 1000 Hz a deviation of 0.1 dB can be detected

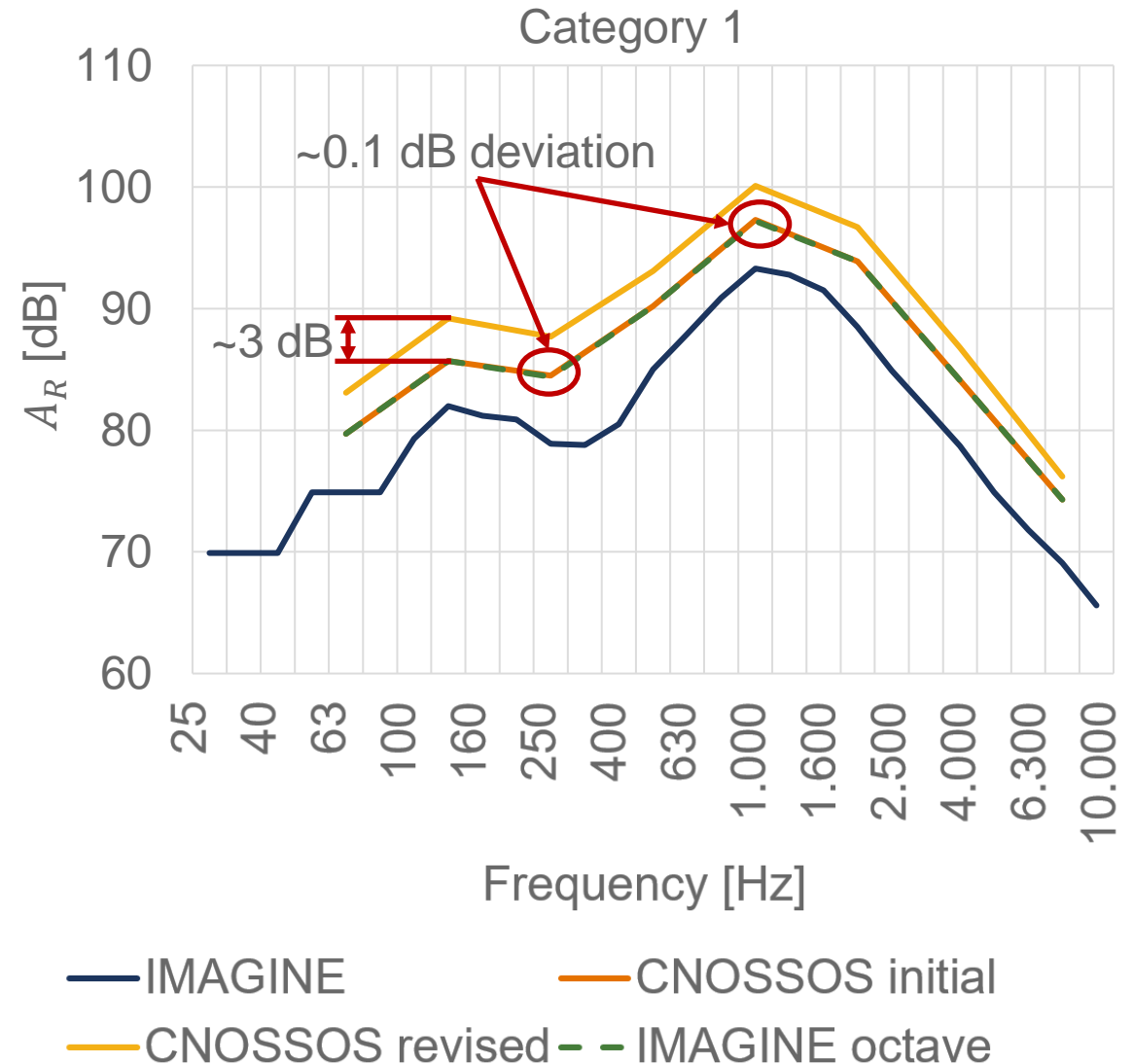

Coefficients [EUR15], [EUR21] & [IMA07b]

- » Speed-dependent rolling coefficients
- » Note: CNOSSOS octave and IMAGINE 1/3 octave
- » Key messages:
 - » High agreement of CNOSSOS and IMAGINE coefficients (fitting of IMAGINE data)

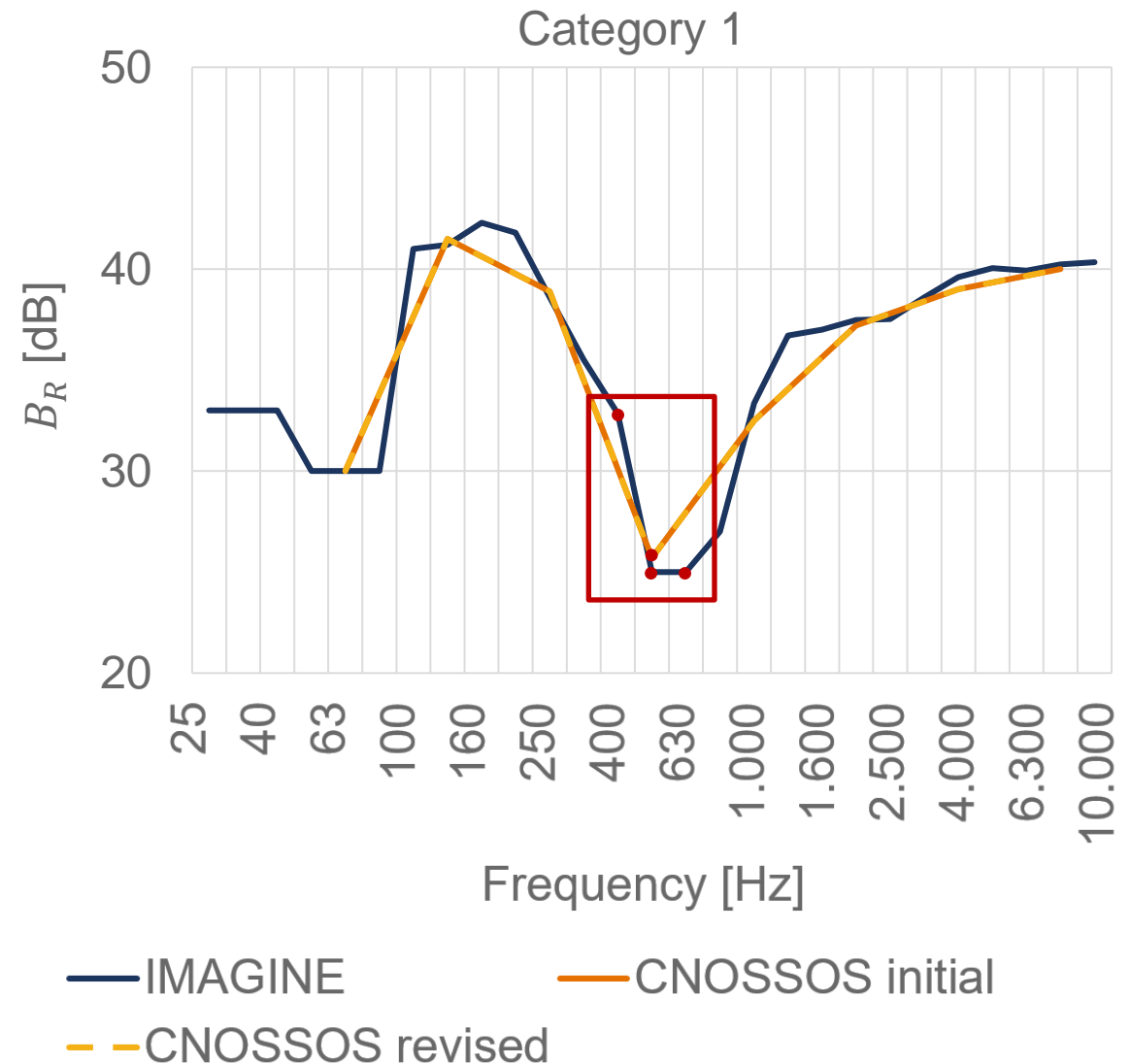

Coefficients [EUR15], [EUR21] & [IMA07b]

- » Speed-independent propulsion coefficients
- » Note: CNOSSOS octave and IMAGINE 1/3 octave
- » Key messages (Similar to A_R):
 - » Summing the 1/3 octaves from IMAGINE results in the initial CNOSSOS coefficients
 - » No deviation of 0.1 dB can be detected

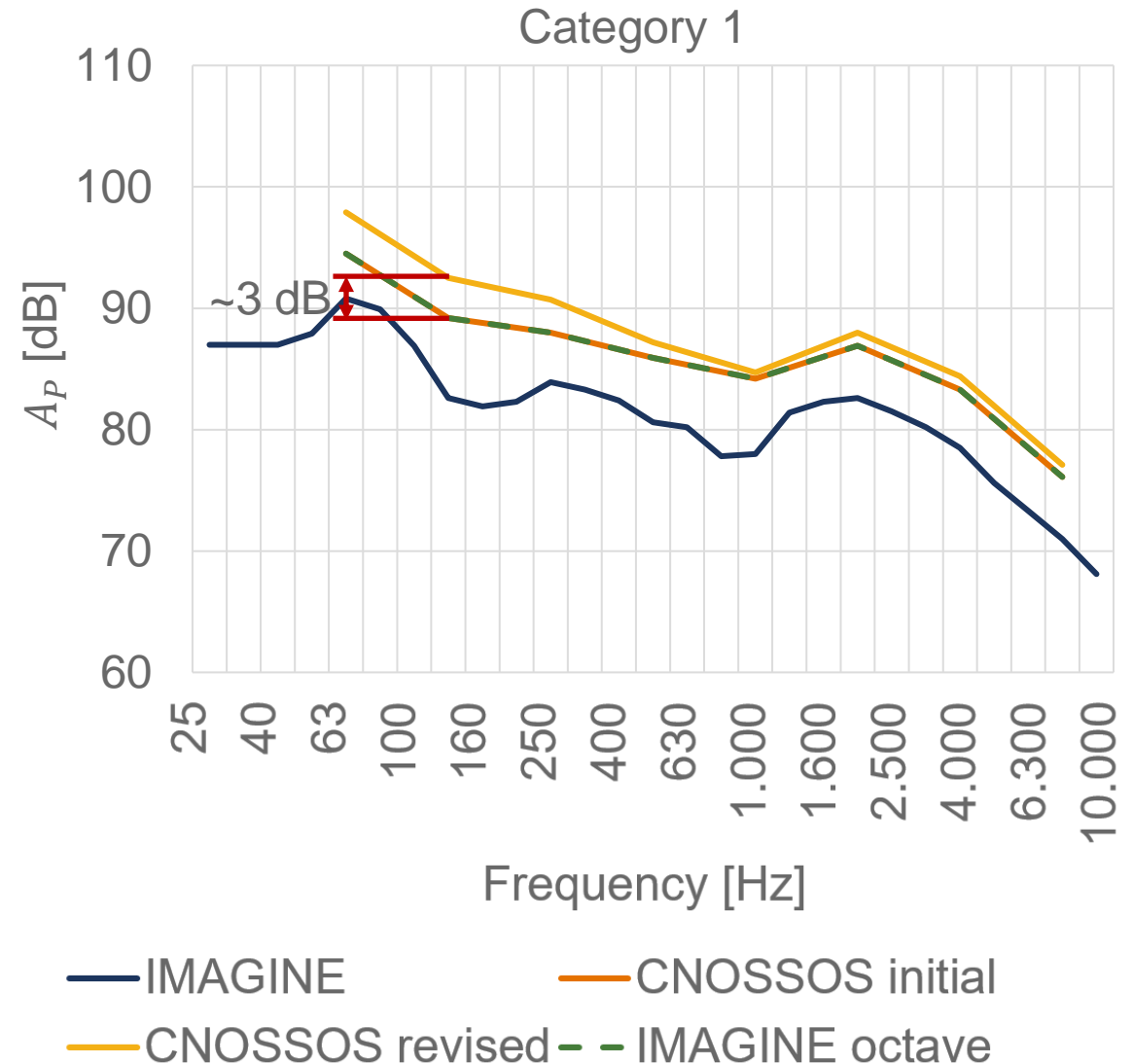

Coefficients [EUR15], [EUR21] & [IMA07b]

- » Speed-dependent propulsion coefficients
- » Note: CNOSSOS octave and IMAGINE 1/3 octave
- » Key messages (Similar to B_R):
 - » High agreement of CNOSSOS and IMAGINE coefficients (fitting of IMAGINE data)

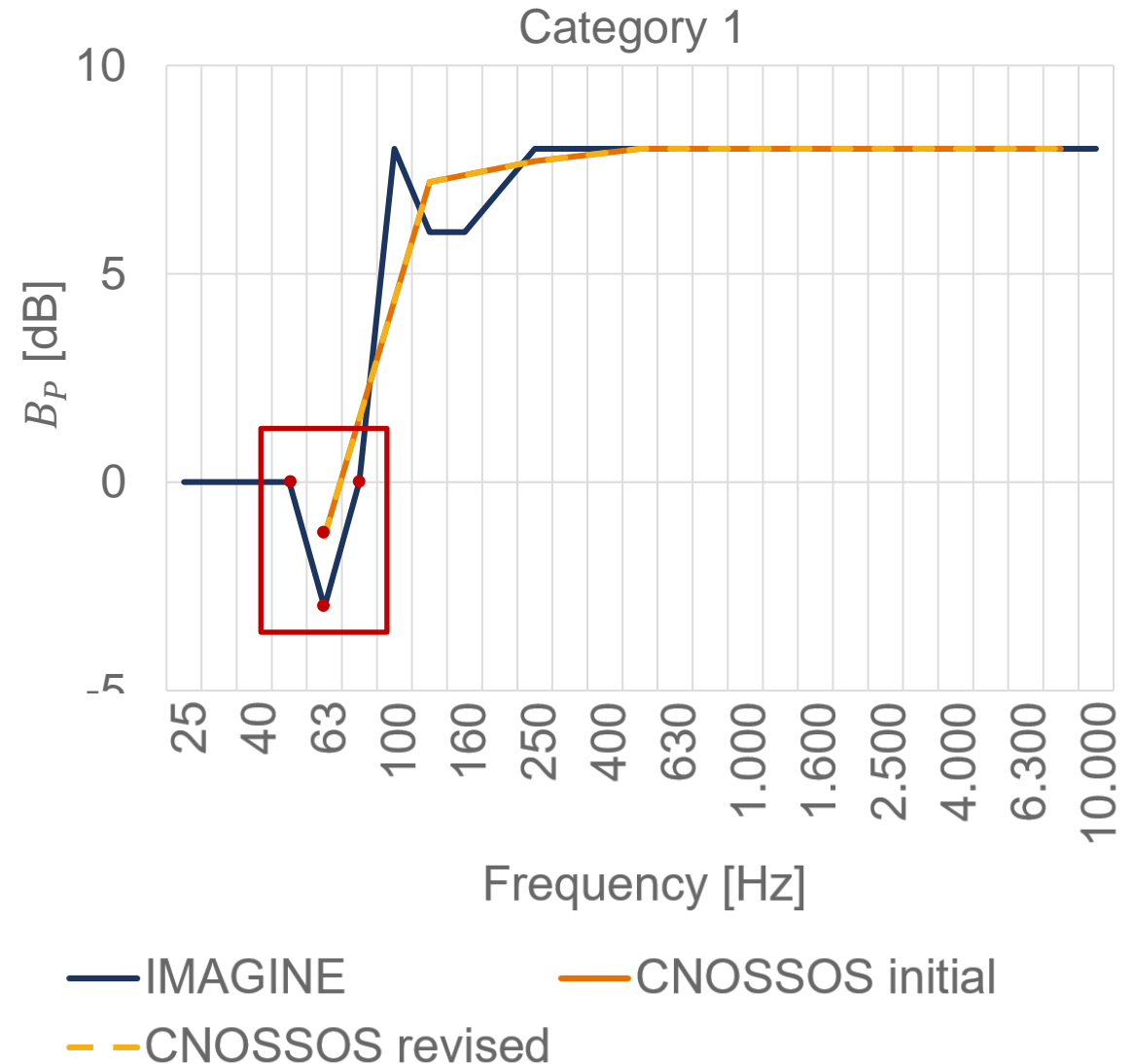

CNOSSOS-EU revision [EUR21]

- » Adaptions were made for, e.g.
 - » Correction factors
 - » Sound power coefficients
- » Revision was needed because, i.e.
 - » Difference in propagation models (see below and detailed explanation on **slides 89-90**)

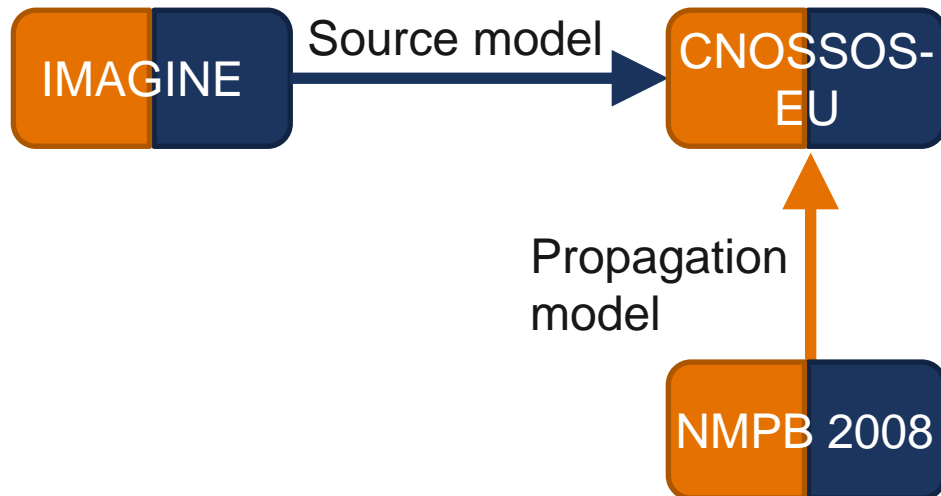

Difference of A-coefficients for category 1 in [EUR21] & [EUR15]: $(A_{2021} - A_{2015})$

		Frequency [Hz]							
		63	125	250	500	1000	2000	4000	8000
cat. 1	A_R	3,40	3,50	3,20	2,90	2,80	2,80	2,70	1,90
	A_P	3,40	3,30	2,70	1,30	0,50	1,10	1,10	1,00
cat. 2	A_R	4,70	4,50	4,20	4,20	4,30	4,20	4,00	3,10
	A_P	4,50	3,70	1,70	1,90	2,40	2,60	2,40	2,30
cat. 3	A_R	4,70	4,50	4,10	4,20	4,30	4,20	4,00	3,10
	A_P	4,40	3,60	1,80	1,90	2,50	2,60	2,50	2,20
cat. 4a	A_R	0,00	0,00	0,00	0,00	0,00	0,00	0,00	0,00
	A_P	5,00	5,50	4,00	1,60	0,60	1,60	1,90	2,20
cat. 4b	A_R	0,00	0,00	0,00	0,00	0,00	0,00	0,00	0,00
	A_P	4,90	4,70	4,00	1,50	0,50	1,50	2,00	2,10

Same colours → similar change

[EUR15] [EUR21]

Similar adaptions for:

- » cat. 2 and 3
- » cat. 4a and 4b

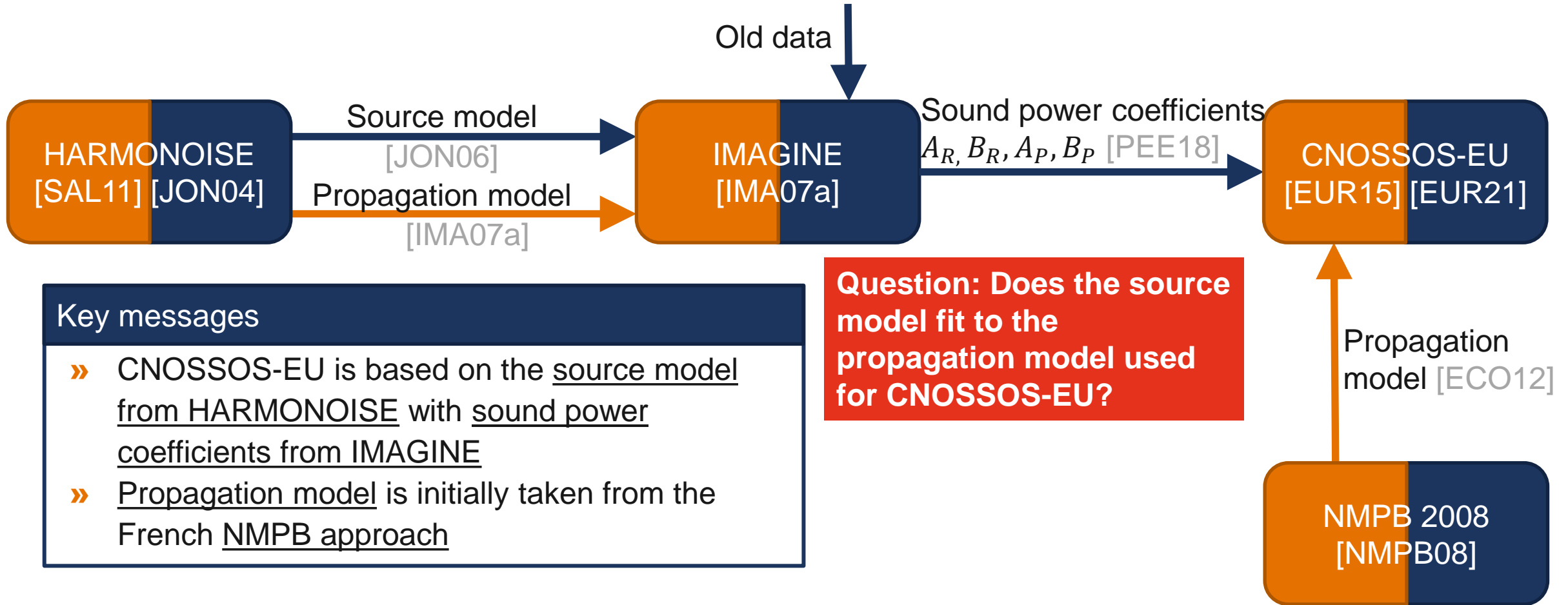

■ Source model ■ Propagation model

Detailed Analysis on CNOSSOS-EU & HARMONOISE/ IMAGINE

Sound source modeling differences

CNOSSOS-EU

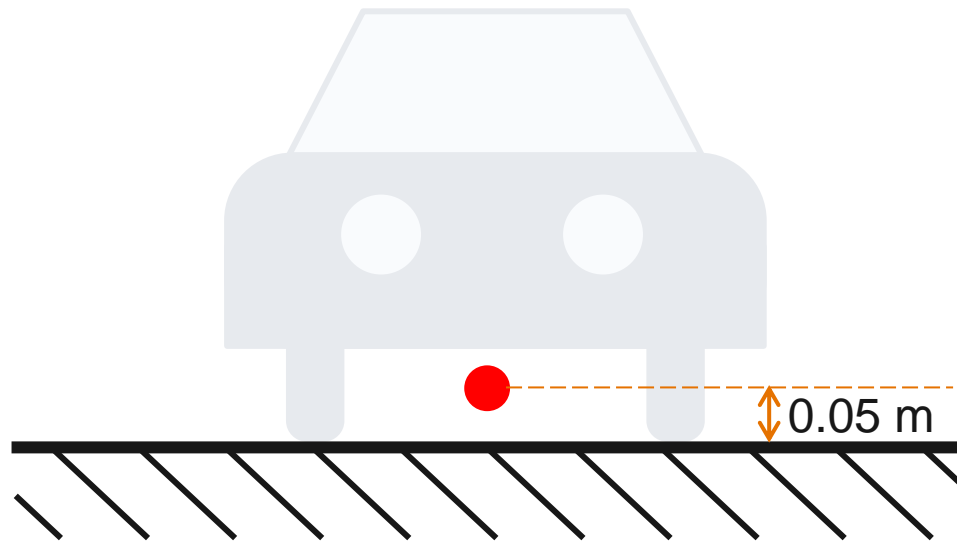

CNOSSOS-EU source model

- » One source at $h = 0.05$ m

HARMONOISE/ IMAGINE

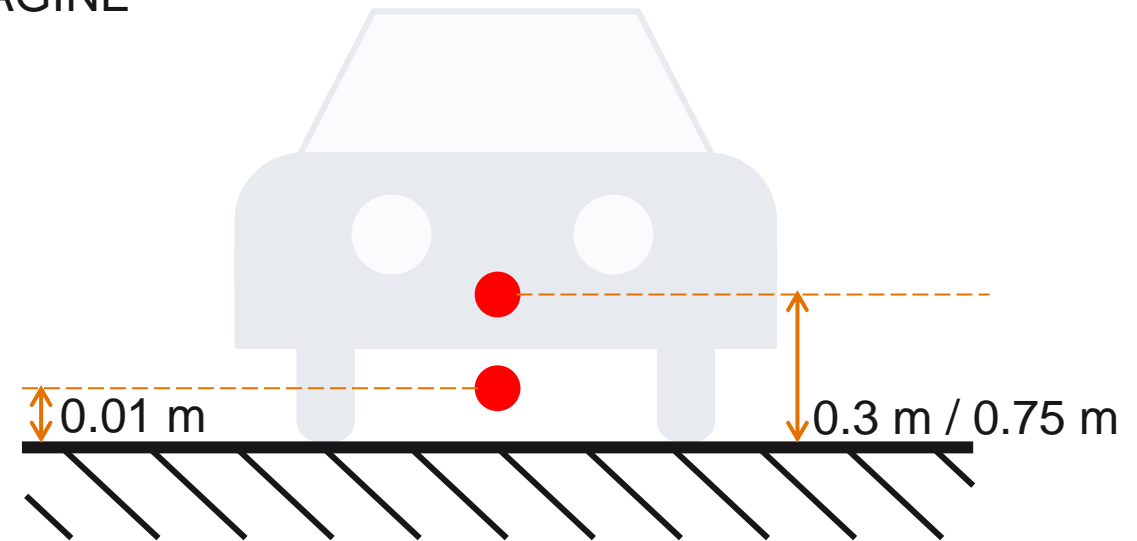

HARMONOISE/IMAGINE source model

- » Source position and quantity depends on vehicle category, e.g., for passenger cars:
 - » One source at $h = 0.01$ m
 - » One source at $h = 0.3$ m

Detailed Analysis on CNOSSOS-EU & HARMONOISE/ IMAGINE

Sound propagation modeling differences

CNOSSOS-EU

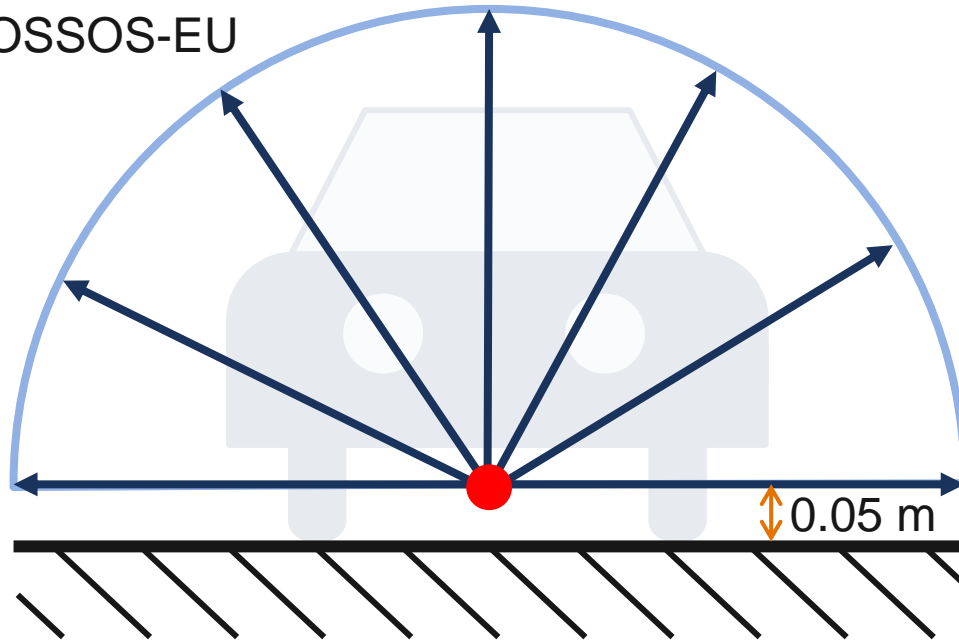

CNOSSOS-EU propagation model (from NMPB)

- » Reflection of road surface is included implicitly (hemispherical radiation → doubled sound power)
- » Incoherent: $L_{sum} = 10 \cdot \log(10^{0.1 \cdot L_1} + 10^{0.1 \cdot L_2})$ [PEE18]
- +3 dB for reflective surface without absorption

HARMONOISE/
IMAGINE

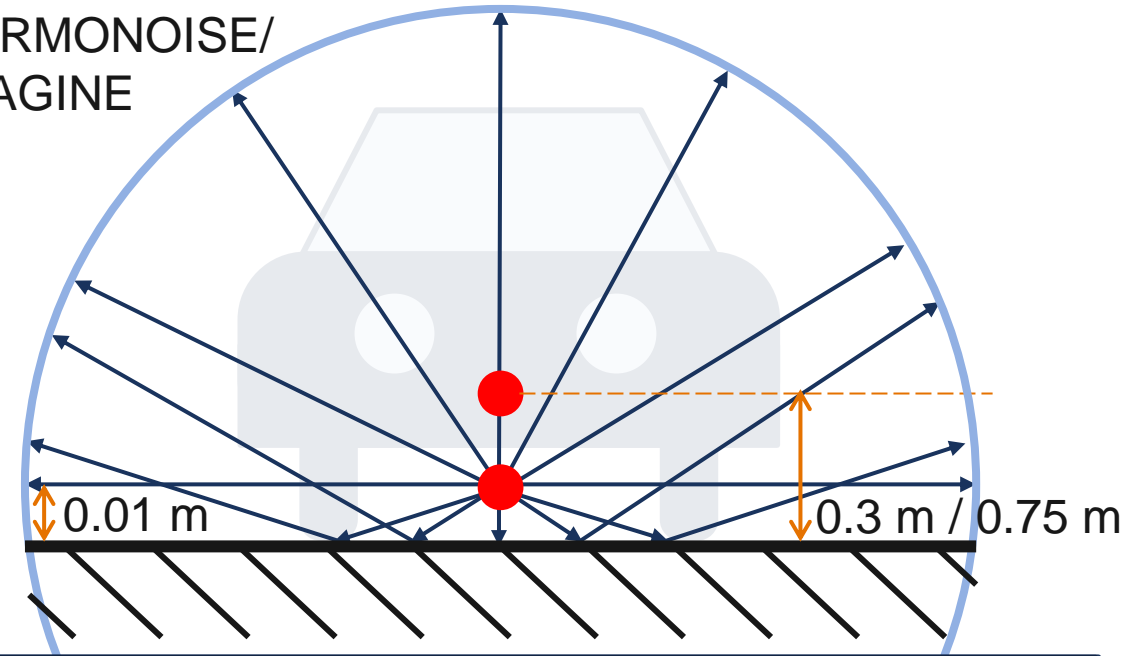

HARMONOISE/IMAGINE propagation model

- » Free-field conditions radiating spherically
- » Coherent: $L_{sum} = 20 \cdot \log\left(\frac{p_1 p_2}{p_0}\right)$ [VAN12]
- +6 dB for constructive interference

Detailed Analysis on CNOSSOS-EU & HARMONOISE/ IMAGINE

Sound propagation modeling differences

Estimation of sound power coefficients

- » Sound power coefficients originate from measurement campaigns
- » SPB measurements have been conducted
 - » Source close to the road surface → Path difference neglected (see figure on the right)
 - » Summation of coherent sounds → ≤ 6 dB
- » This fact was well known in IMAGINE:
 1. “[...] interference between direct and reflected components are strongly affected by variation in source height” [IMA07a]
 2. “[...] accounted for by using a smeared out source position” [IMA07a]
 3. However: Direct and reflected added including their phase

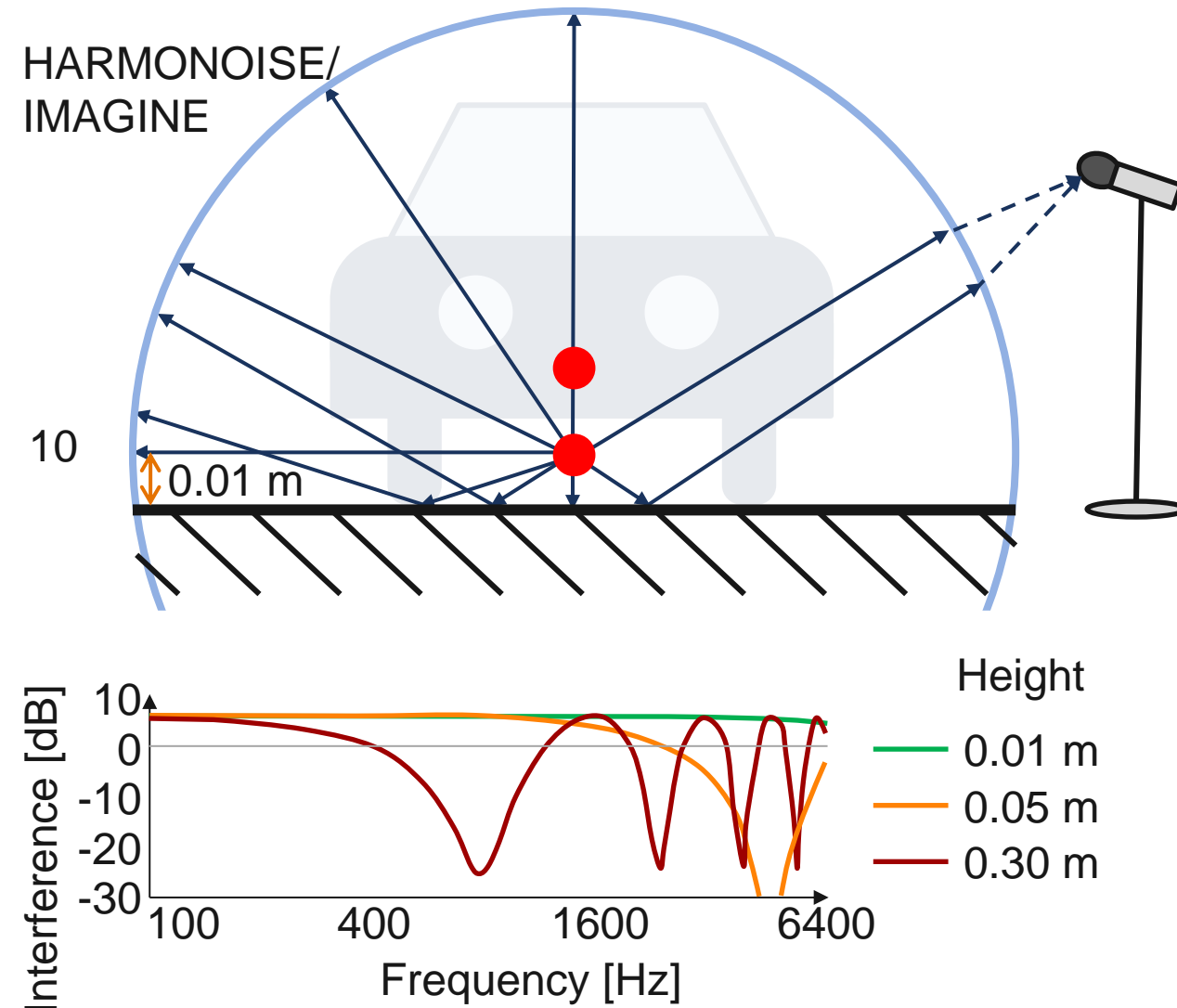

Propagation model change

- » While taking the **source model** description from the **HARMONOISE/ IMAGINE** project, the **propagation model** was chosen to be the French **NMPB 2008** provisionally [KEP14]
 - » Differences in the transfer functions (resulting from the propagation model) for **HARMONOISE** and **CNOSSOS-EU** can be seen on the right
 - » Distinctions in the source model between **CNOSSOS-EU** and **IMAGINE** shown on **slide 20-23 and slide 88**

Transfer functions from L_W to SEL for $v_{ref} = 70 \frac{\text{km}}{\text{h}}$
[PEE18]

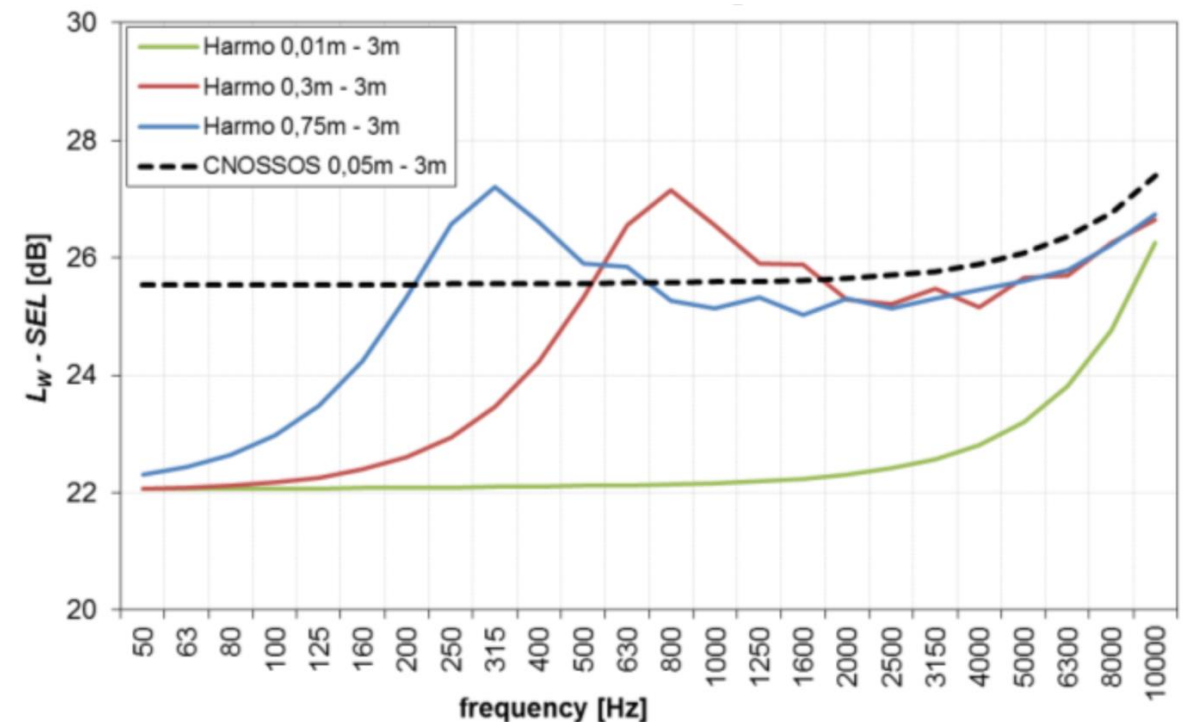

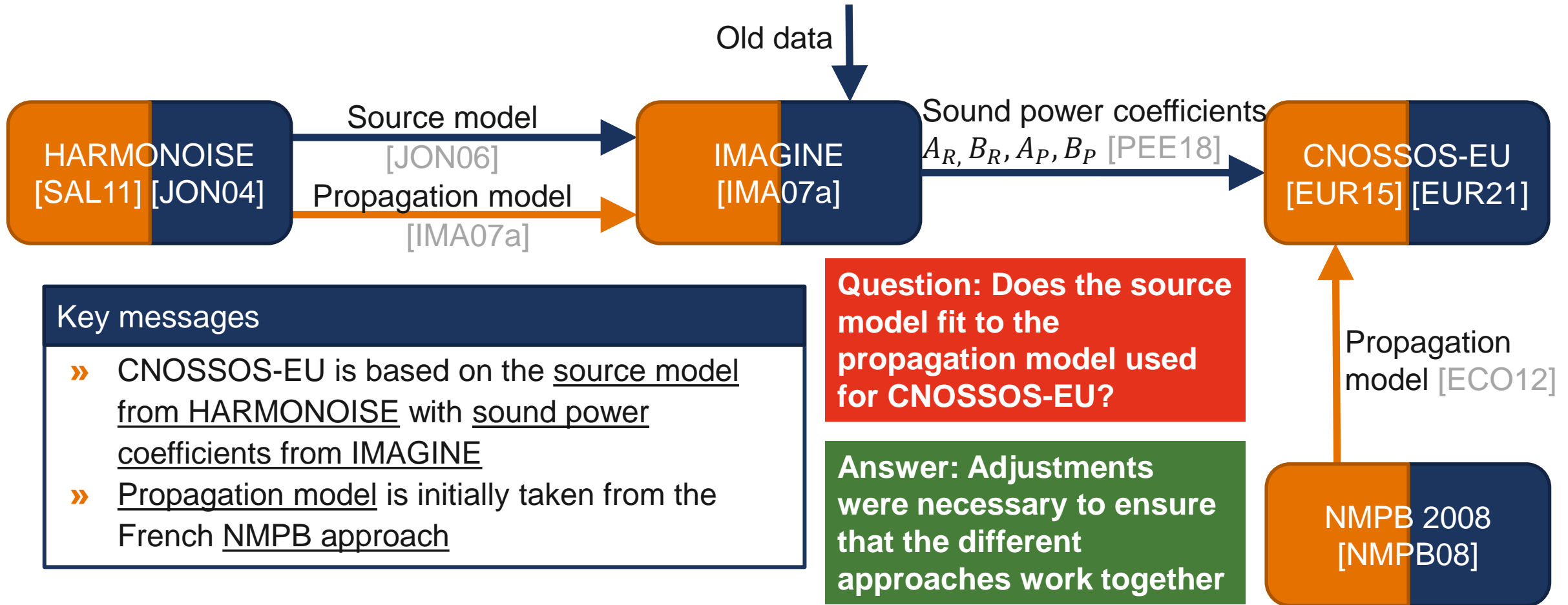

Key messages

- » CNOSSOS-EU is based on the source model from HARMONOISE with sound power coefficients from IMAGINE
- » Propagation model is initially taken from the French NMPB approach

Question: Does the source model fit to the propagation model used for CNOSSOS-EU?

Answer: Adjustments were necessary to ensure that the different approaches work together

These adjustments were not performed for the initial coefficients in [EUR15] and therefore needed for be done for the revision in 2021.

Detailed Analysis on CNOSSOS-EU & HARMONOISE/IMAGINE

CNOSSOS-EU Revision – Timeline

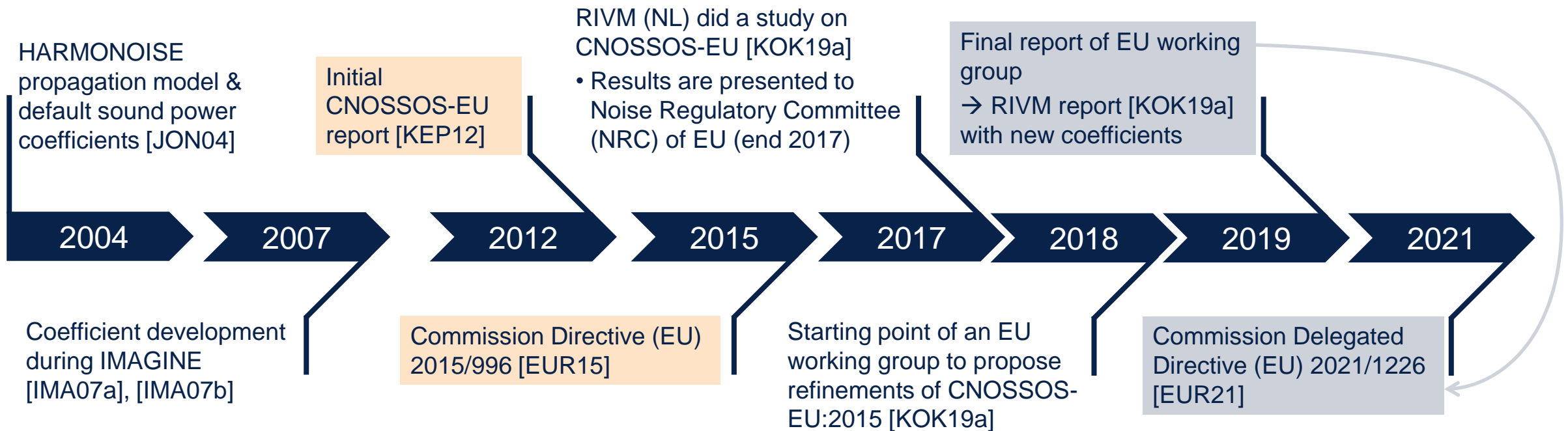

CNOSSOS-EU:2015 coefficients CNOSSOS-EU:2021 coefficients

(7) Page 98 section 16.29.2 [KOK19a]
 The table is incorrect. It currently reflects values valid only for the Netherlands. This table is changed to:

Category	Coefficient	63	125	250	500	1000	2000	4000	8000
1	A_R	83.1	89.2	87.7	93.1	100.1	96.7	86.8	76.2
	B_R	30.0	41.5	38.9	25.7	32.5	37.2	39.0	40.0
	A_P	97.9	92.5	90.7	87.2	84.7	88.0	84.4	77.1
	B_P	-1.3	7.2	7.7	8.0	8.0	8.0	8.0	8.0
2	A_R	88.7	93.2	95.7	100.9	101.7	95.1	87.8	83.6
	B_P	30.0	35.8	32.6	23.8	30.1	36.2	38.3	40.1

Procedure for revised CNOSSOS-EU coefficients

- » The procedure for the updated CNOSSOS-EU coefficients is presented in [PEE18]
- » It is based on
 - » „old“ coefficients from 2015
 - » Transfer functions (TFs) from the HARMONOISE/ IMAGINE propagation model
 - » TFs: calculated difference between L_{WZ} at the source and SEL at the receiver
 - » With are three different TFs depending on the different source heights
 - » Transfer function (TF) from CNOSSOS-EU sound propagation model

Approach (short summary)

1. The 2015 coefficients and the HARMONOISE/ IMAGINE transfer functions are used to calculate the sound exposure level (SEL on a hypothetical microphone position)
 - a. For rolling as well as for propulsion noise
 - b. For each vehicle category
 2. The CNOSSOS-EU TF is applied and by using the contributions of rolling and propulsion noise the revised coefficients are calculated
- » This means that no additional measurements were performed for the revision

Detailed Analysis on CNOSSOS-EU & HARMONOISE/ IMAGINE

CNOSSOS-EU Revision – Procedure [PEE18]

The initial coefficients (divided into rolling and propulsion) were used to calculate SELs at the different source heights defined in HARMONOISE

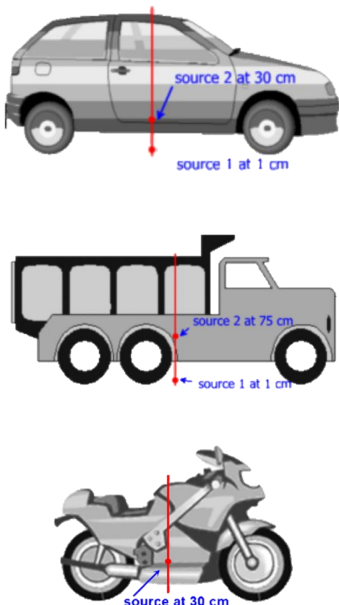
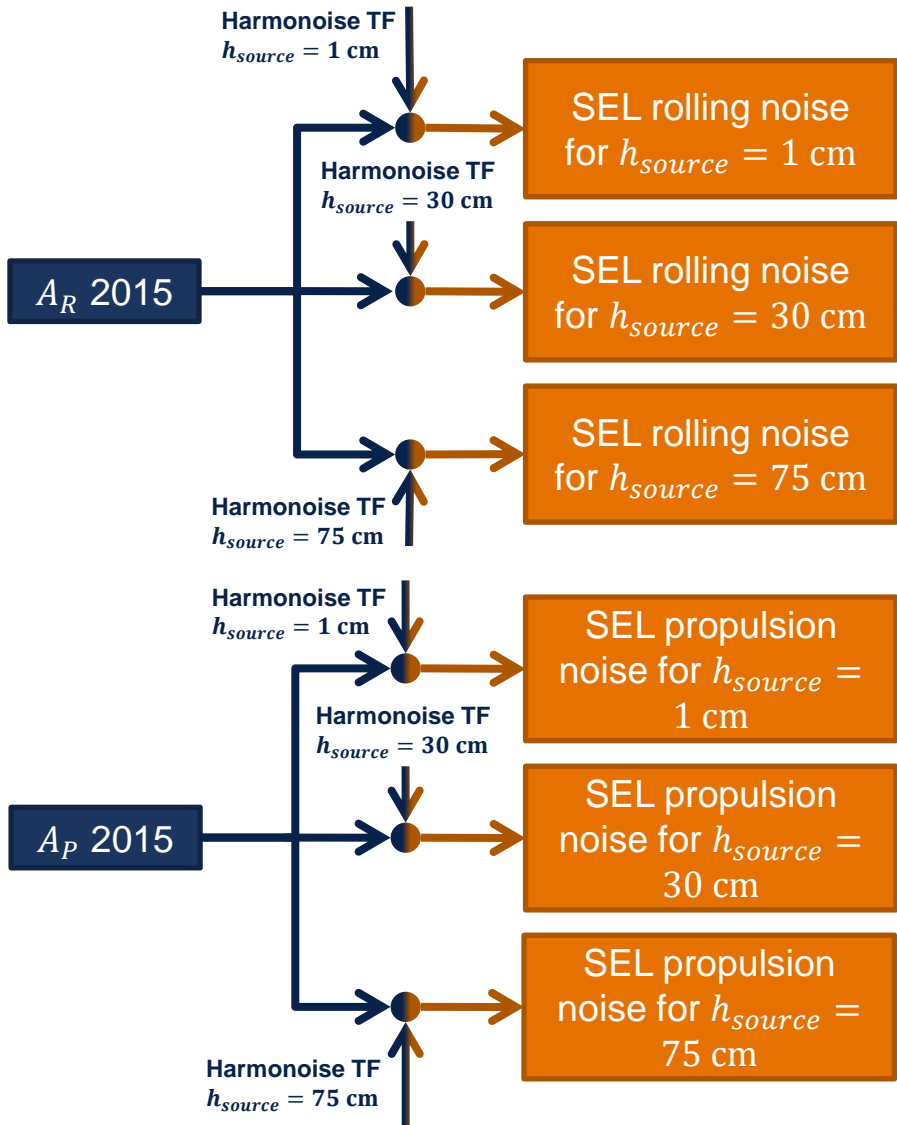

Transfer functions from $L_{W,source}$ to $SEL_{receiver}$ [IMA07a]

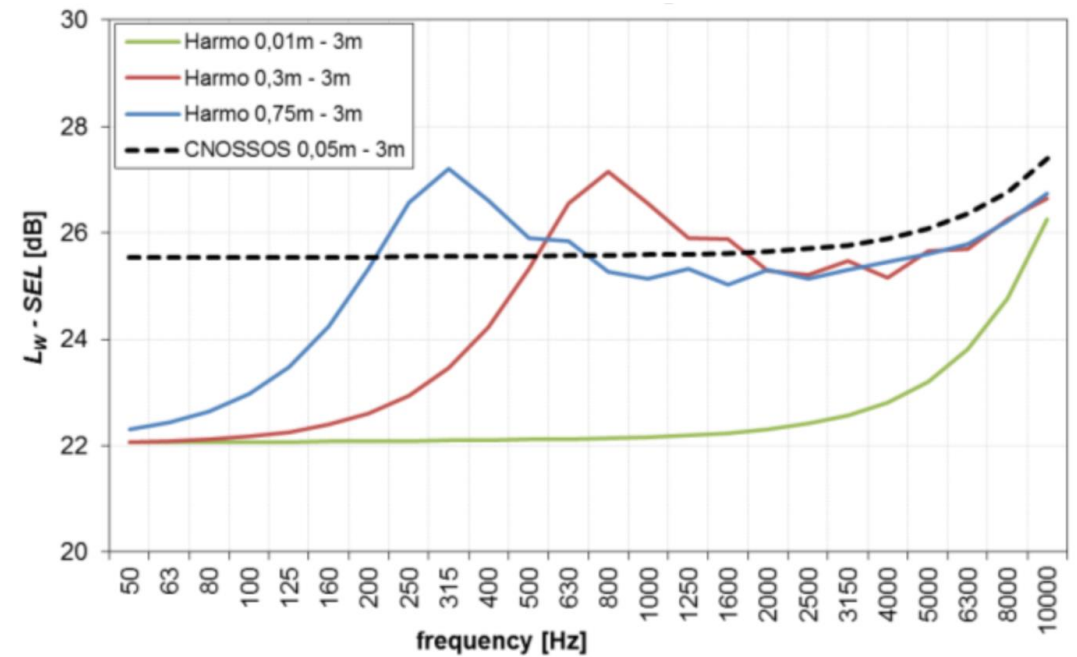

Source position Receiver position

Detailed Analysis on CNOSSOS-EU & HARMONOISE/ IMAGINE

CNOSSOS-EU Revision – Procedure [PEE18]

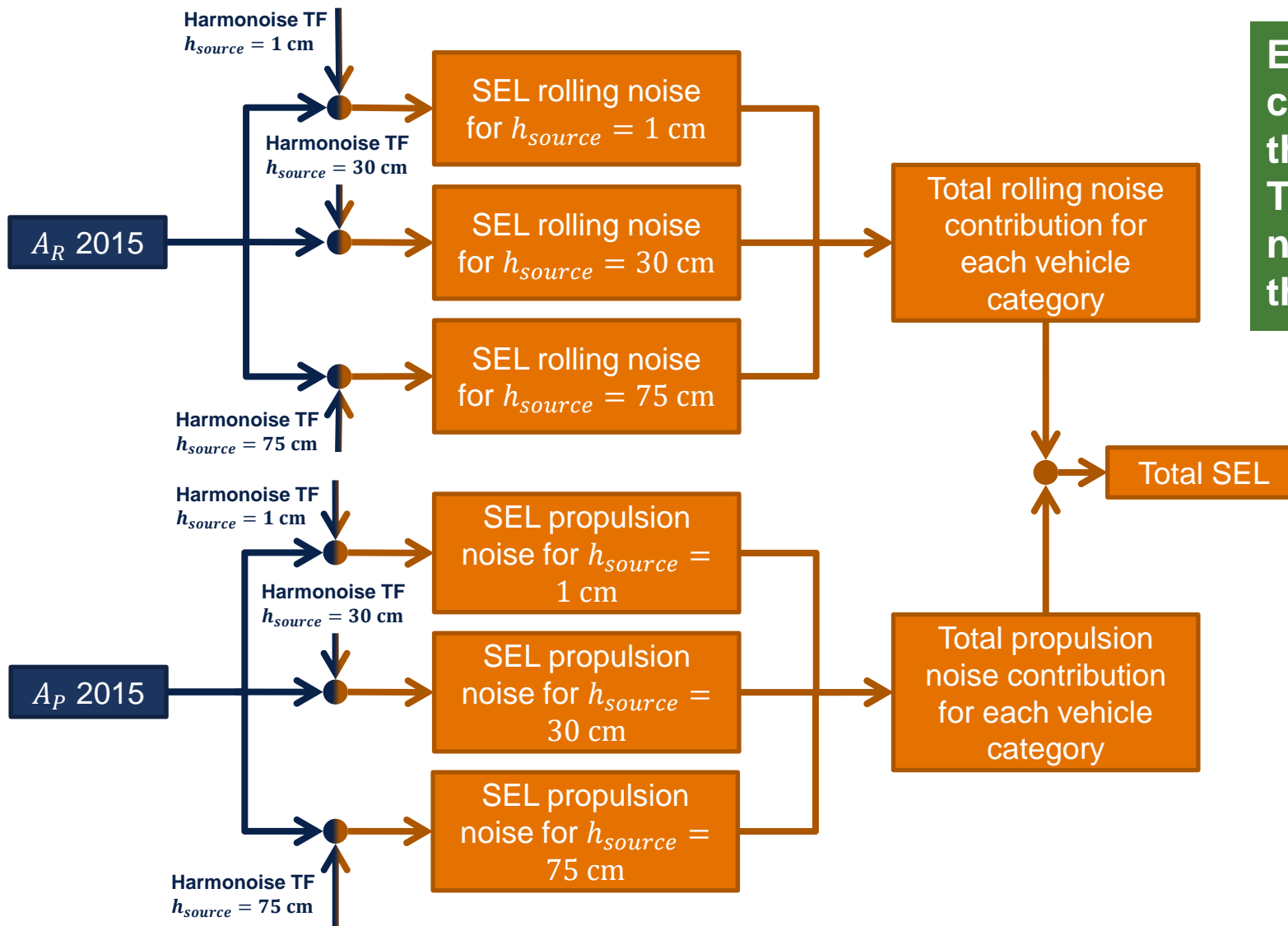

Each vehicle category has a different contribution of the point sources to the overall noise. The calculation of the overall SEL needs to be performed depending on those contributions.

Source position

Receiver position

Detailed Analysis on CNOSSOS-EU & HARMONOISE/ IMAGINE

CNOSSOS-EU Revision – Procedure [PEE18]

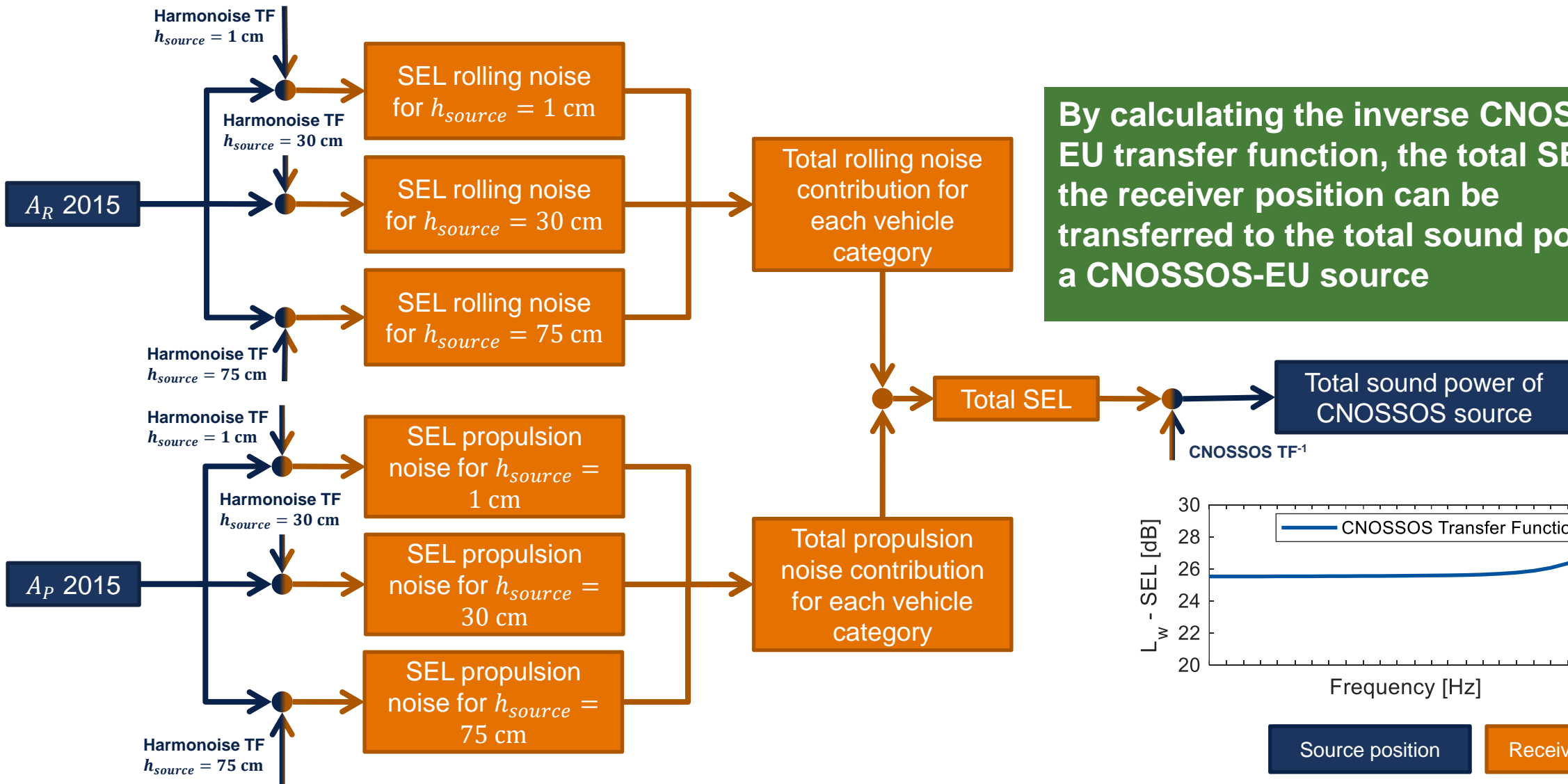

By calculating the inverse CNOSSOS-EU transfer function, the total SEL at the receiver position can be transferred to the total sound power of a CNOSSOS-EU source

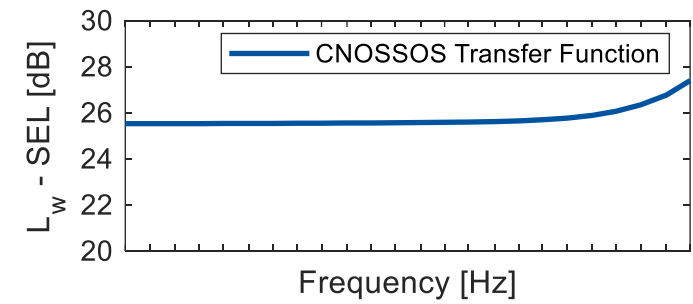

Source position Receiver position

Detailed Analysis on CNOSSOS-EU & HARMONOISE/ IMAGINE

CNOSSOS-EU Revision – Procedure [PEE18]

To correct the CNOSSOS sound power coefficients for the change in propagation models, we follow the following procedure:

1. Start with the IMAGINE A_R and A_P coefficients, which are equal to the Directive 2015/996 Table F-1 values, but in 1/3-octave bands.
2. Using the Harmonoise transfer functions, as shown in Figure 6, calculate the rolling and propulsion noise SEL levels at the measurement position (7.5 m distance, 3.0 m height), for each of the IMAGINE source heights (1, 30, 75 cm).
3. For each vehicle category, calculate
 - a. the total rolling noise contribution, by adding 80% of the sound energy at the lowest source (1 cm) and 20% of the energy at the highest source (30 or 75 cm), and
 - b. the total propulsion noise contribution, by adding 20% of the lowest source and 80% of the highest source.
4. Calculate the total SEL at the measurement position by adding the rolling noise and propulsion noise from 3a and 3b. These levels are exactly equal to the average SEL levels found from the measurements.
5. Calculate the total sound power for the CNOSSOS sound source at 5 cm height, using the transfer functions calculated with the CNOSSOS propagation model (see Table I).

6. Divide the sound power between rolling noise and propulsion noise contributions, using the original values:

- a. rolling noise = result step 5 – (result step 4 – result step 3a),
- b. propulsion noise = result step 5 – (result step 4 – result step 3b).

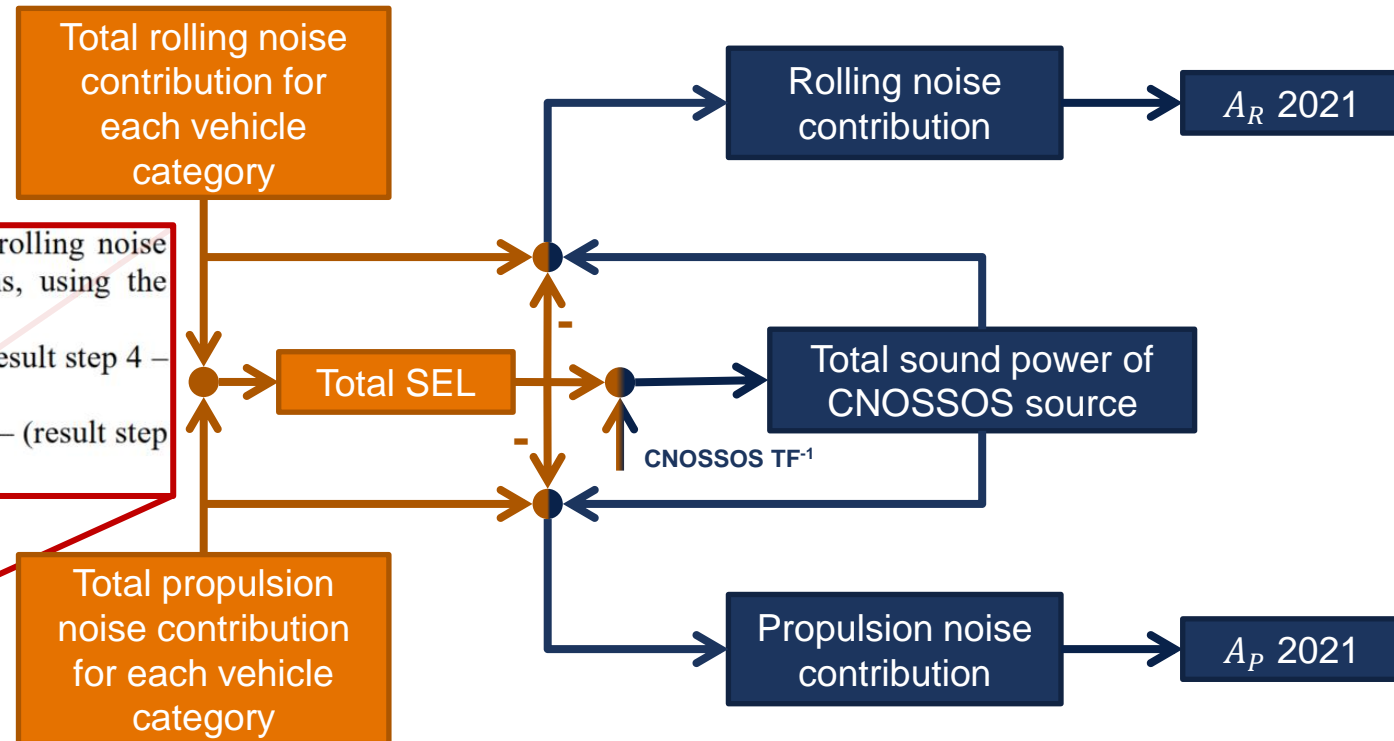

7. Calculate the CNOSSOS-EU coefficients for rolling and propulsion noise by summing the 1/3-octave band values to 1/1-octave bands. [PEE18]



For obtaining the rolling/ propulsion noise contribution, the vice versa contribution needs to be subtracted from of overall sound power, meaning:

- » Rolling contribution = total sound power – propulsion contribution
- » Propulsion contribution = total sound power – rolling contribution

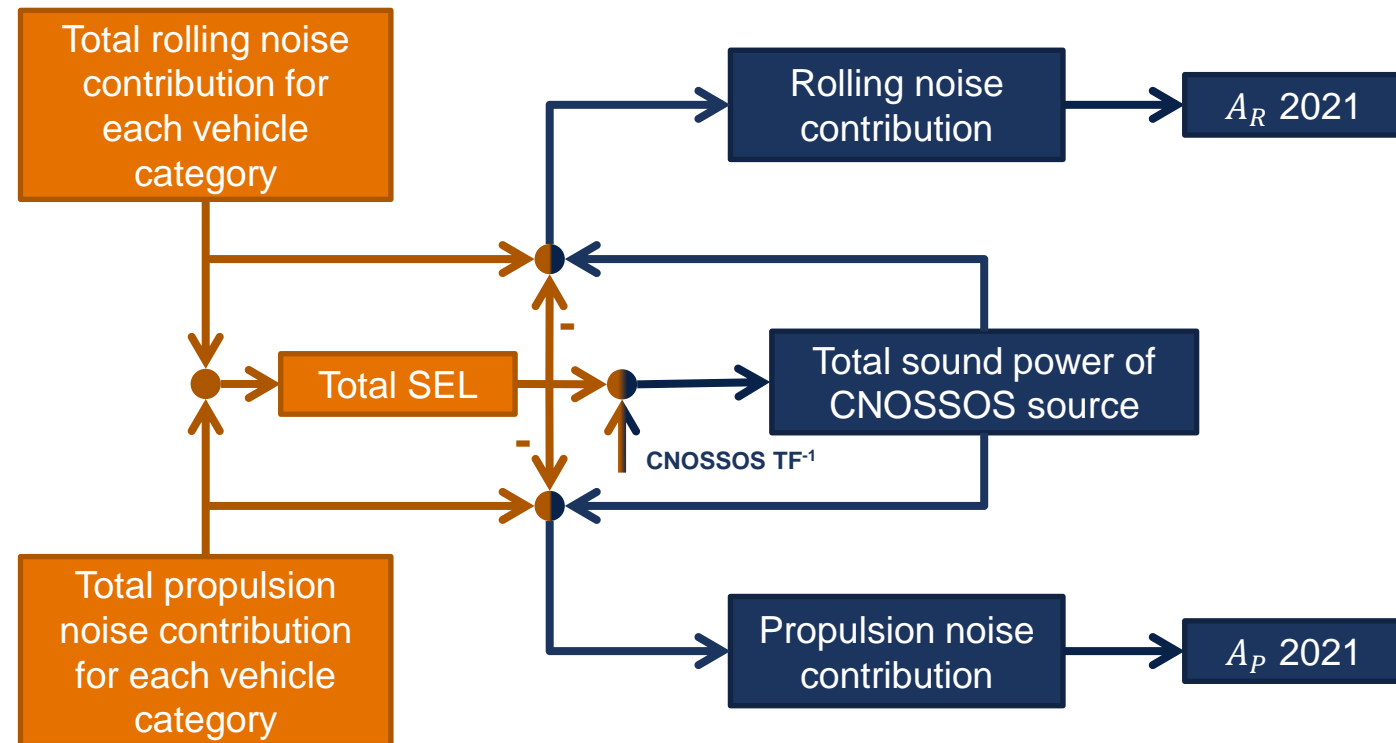

Source position

Receiver position

Detailed Analysis on CNOSSOS-EU & HARMONOISE/ IMAGINE

CNOSSOS-EU Revision – Procedure [PEE18]

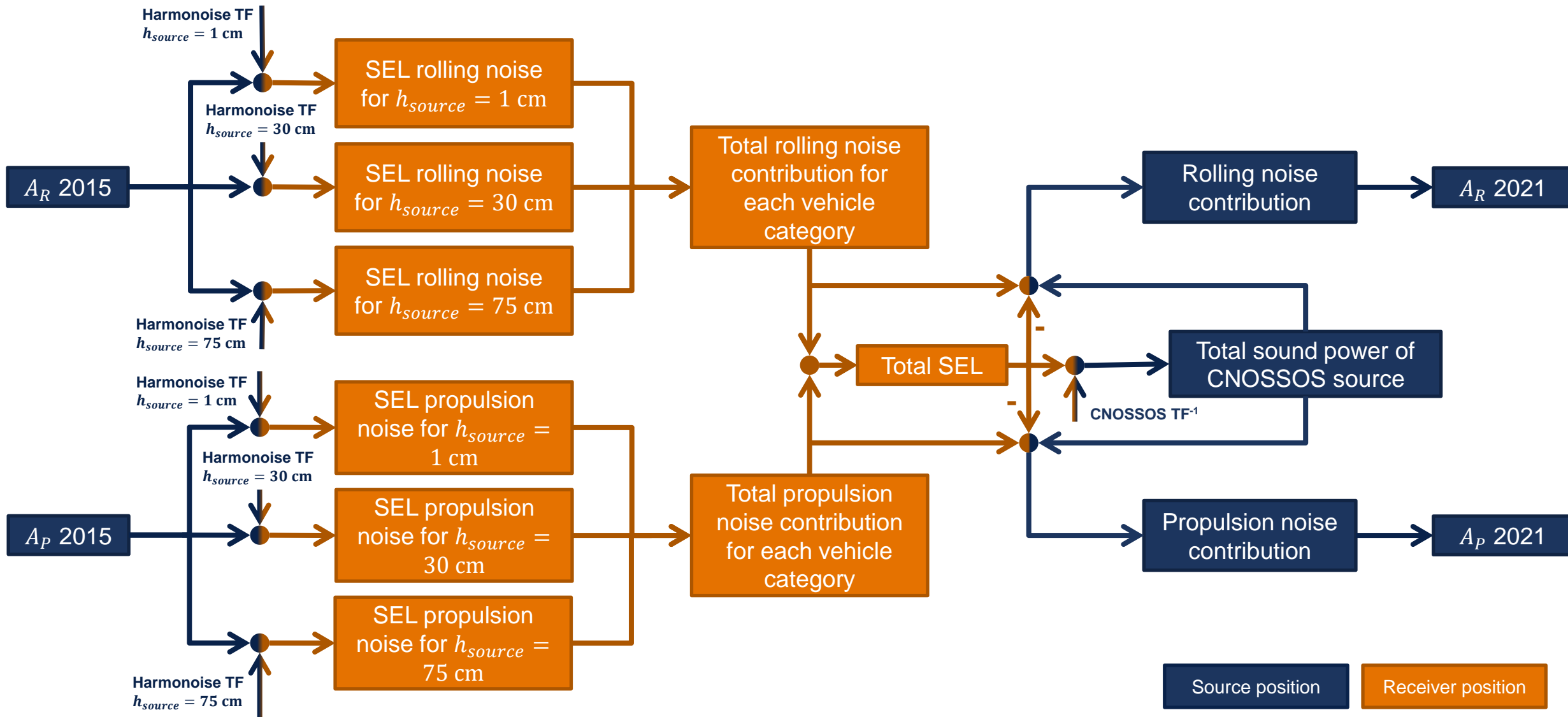

Objective	HARMONOISE/ IMAGINE [IMA07a]	CNOSSOS-EU [EUR15], [EUR21]
Source modeling	<p><u>Frequency dependent sound power coefficients</u></p> <ul style="list-style-type: none"> » <u>Two vehicle sound sources</u> with speed-independent (A-coefficients) and speed-dependent (B-coefficients) contribution <ul style="list-style-type: none"> » Propulsion noise $\rightarrow A_P, B_P$ » Rolling noise $\rightarrow A_R, B_R$ » Originated from <u>extensive measurement campaigns</u> 	
Frequency resolution	<ul style="list-style-type: none"> » 1/3 Octave bands 	<ul style="list-style-type: none"> » Octave bands (initial coefficients extracted from IMAGINE)

Estimation of sound power coefficients during IMAGINE

- » Coefficients originate from measurement campaigns (see more on **slide 28 onwards**)
- » Statistical pass-by (SPB) measurements have been conducted
 - » Microphone 7.5 m aside & heights of 1.2 m and 3 m

Detailed Analysis on CNOSSOS-EU & HARMONOISE/ IMAGINE

Overview of similarities and differences

Objective	HARMONOISE/ IMAGINE [IMA07a]	CNOSSOS-EU [EUR15]
Vehicle categories	» Category 1: light motor vehicles	
	» Category 2: medium heavy vehicles	
	» Category 3: heavy vehicles	
	» Category 4: powered two-wheelers	
		» Category 5: open category
Vehicle speed	» Constant speed at $v_{ref} = 70$ kph	
Air temperature	» $T = 20$ °C	
Inputs	» Speed v	
	» Traffic flow Q	
	» Acceleration	

Detailed Analysis on CNOSSOS-EU & HARMONOISE/ IMAGINE

Overview of similarities and differences

Objective	HARMONOISE/ IMAGINE [IMA07a]	CNOSSOS-EU [EUR15]
Road characteristics	» Flat road (non-sloped)	
	» Surface as mixture of DAC 0/11 and SMA 0/11	
	» Age \geq 2 years & not at life time end	» Age \geq 2 years & < 7 years
	» Dry surface	
	» Sound reflecting surface	
Tire characteristics	» No studded tires	
Vehicle fleet	» Representing an European average	
	» E.g. category 1: 187 mm tire width, 19 % diesel, 10.5 % delivery vans, no studded tires	

Detailed Analysis on CNOSSOS-EU & HARMONOISE/ IMAGINE

Overview of similarities and differences

Objective	HARMONOISE/ IMAGINE [IMA07a]	CNOSSOS-EU [EUR15]
Correction factors	<ul style="list-style-type: none"> » Regional corrections for fleet composition <ul style="list-style-type: none"> » Engine type » Average vehicle weight & age » Tire width & type (winter/summer) » Illegal silencer systems » Number of axles (HDV) 	<ul style="list-style-type: none"> » Studded tires correction
	<ul style="list-style-type: none"> » Road surface correction 	
	<ul style="list-style-type: none"> » Driving condition correction 	<ul style="list-style-type: none"> » Acceleration correction
	<ul style="list-style-type: none"> » Meteorological correction 	<ul style="list-style-type: none"> » Temperature correction

Detailed Analysis on CNOSSOS-EU & HARMONOISE/ IMAGINE

Overview of similarities and differences

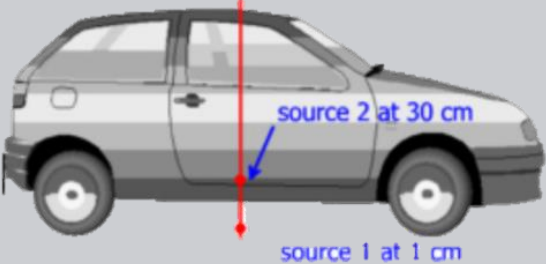
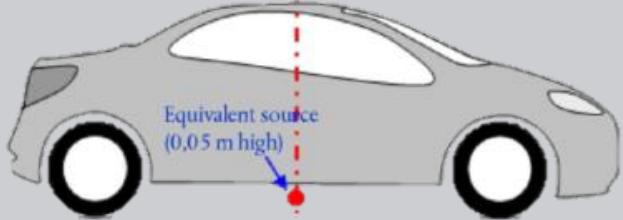
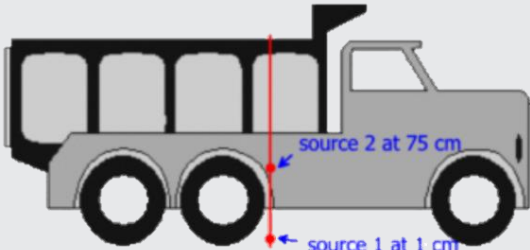
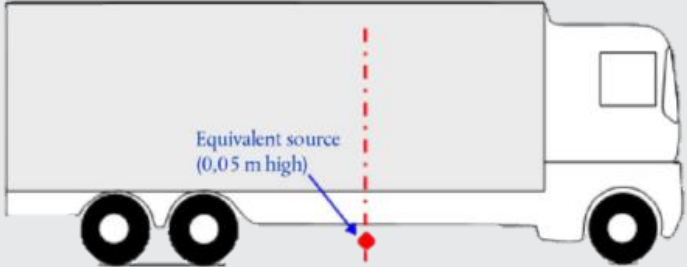
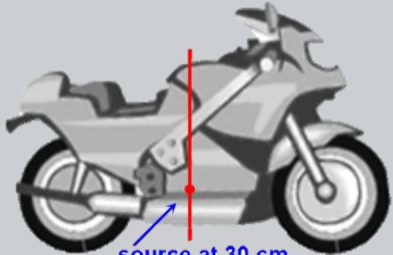
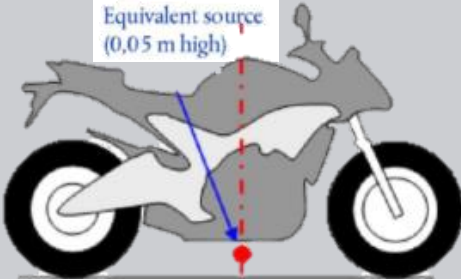
Objective	HARMONOISE/ IMAGINE [IMA07a]	CNOSSOS-EU [EUR15]
Source height	 <p>source 2 at 30 cm</p> <p>source 1 at 1 cm</p>	 <p>Equivalent source (0,05 m high)</p>
	 <p>source 2 at 75 cm</p> <p>source 1 at 1 cm</p>	 <p>Equivalent source (0,05 m high)</p>
	 <p>source at 30 cm</p>	 <p>Equivalent source (0,05 m high)</p>

- » **Project plan**
- » **Work Package 1 → Literature review**
 - » WP 1.1: Analysis of current source description models (END & CNOSSOS-EU)
 - » WP 1.2: Evaluation of noise mapping & management actions
- » **Work Package 2 → Elaboration of correction factors**
 - » WP 2.1: Analysis of existing source description methods
 - » WP 2.2: Determination of source description accuracy
 - » WP 2.3: Suitable adaptations of the source description
- » **Summary**
- » **Outlook**

Determination of source description accuracy

Key questions/ tasks within work package 2.2

1. Illustration by means of an up-to-date vehicle

Due to the decision of analyzing existing data during this project (and not generating new data) this work package (2.2) was investigated within work package (2.3). Results regarding up to date vehicle sound emission can be found from **slide 110 onwards**.

- » **Project plan**
- » **Work Package 1 → Literature review**
 - » WP 1.1: Analysis of current source description models (END & CNOSSOS-EU)
 - » WP 1.2: Evaluation of noise mapping & management actions
- » **Work Package 2 → Elaboration of correction factors**
 - » WP 2.1: Analysis of existing source description methods
 - » WP 2.2: Determination of source description accuracy
 - » WP 2.3: Suitable adaptations of the source description
- » **Summary**
- » **Outlook**

Suitable adaptations of the source description

Key questions/ tasks within work package 2.3

- 1. Overview on relevant vehicle parameters regarding sound emission**
- 2. Overview on relevant changes in legislative boundary conditions**
- 3. Determination of possibilities for integration into existing models**

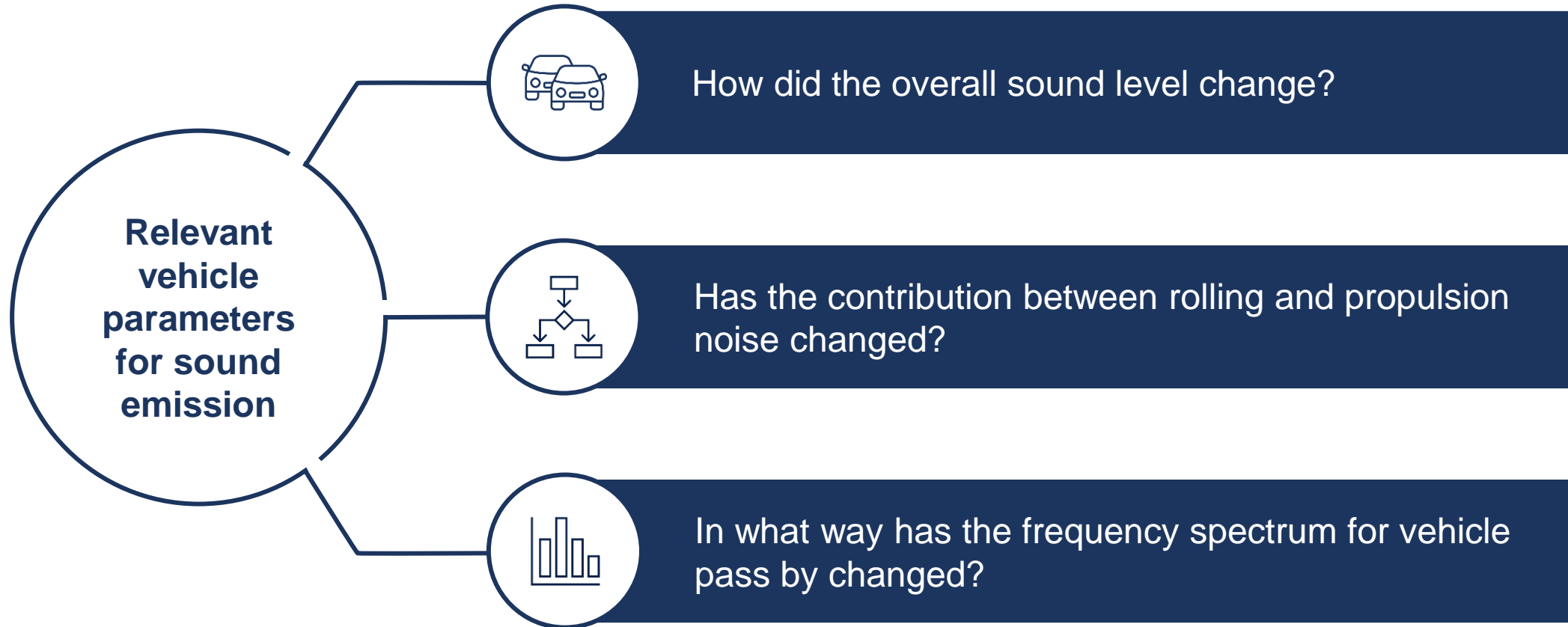

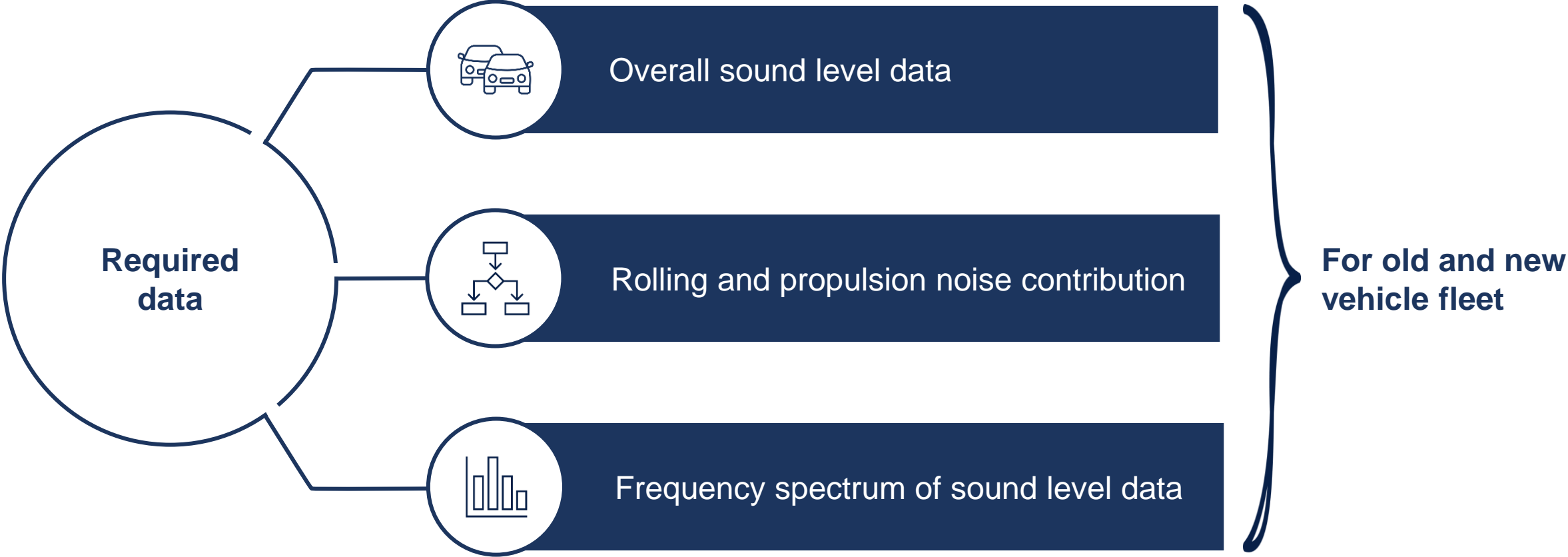

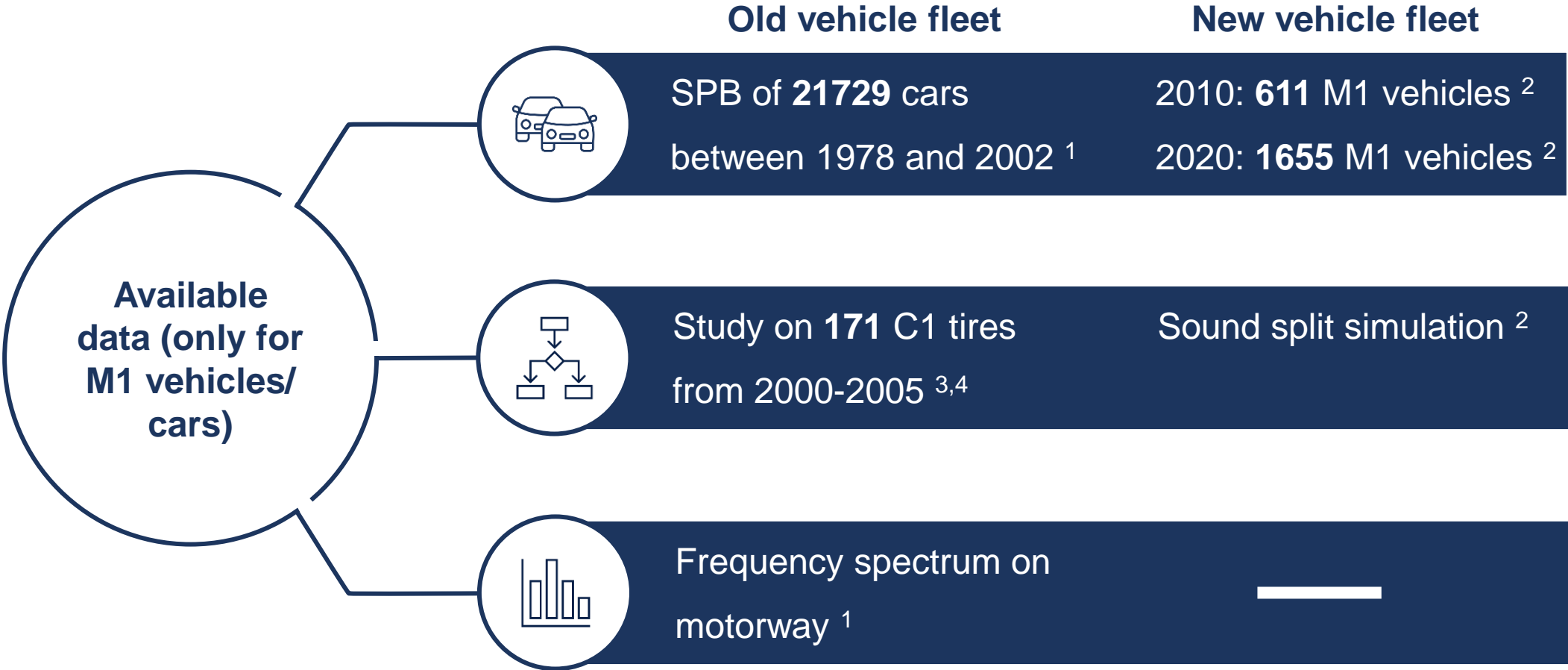

¹ [STE05]
² [ATE22]
³ [FER07]
⁴ [MOR03]

Relevant vehicle parameters regarding sound emission

Overall Sound Level

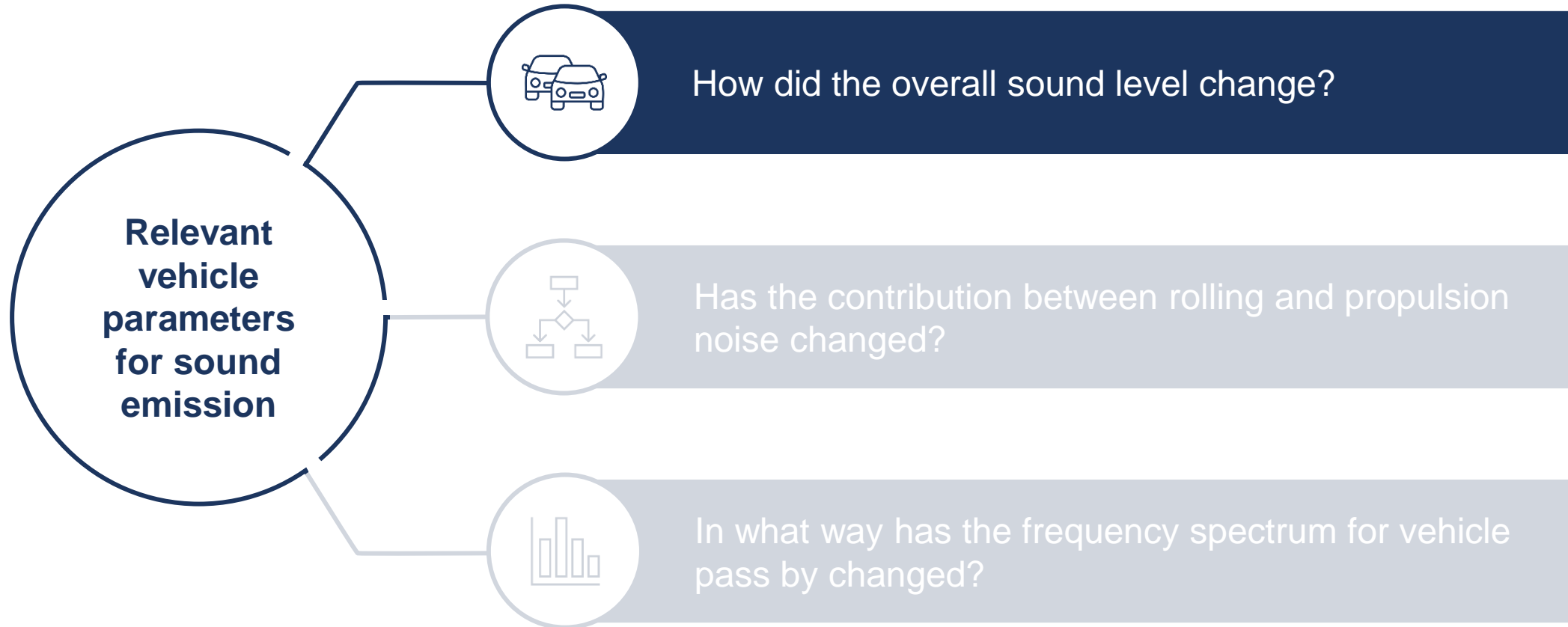

Relevant vehicle parameters regarding sound emission

Overall Sound Level

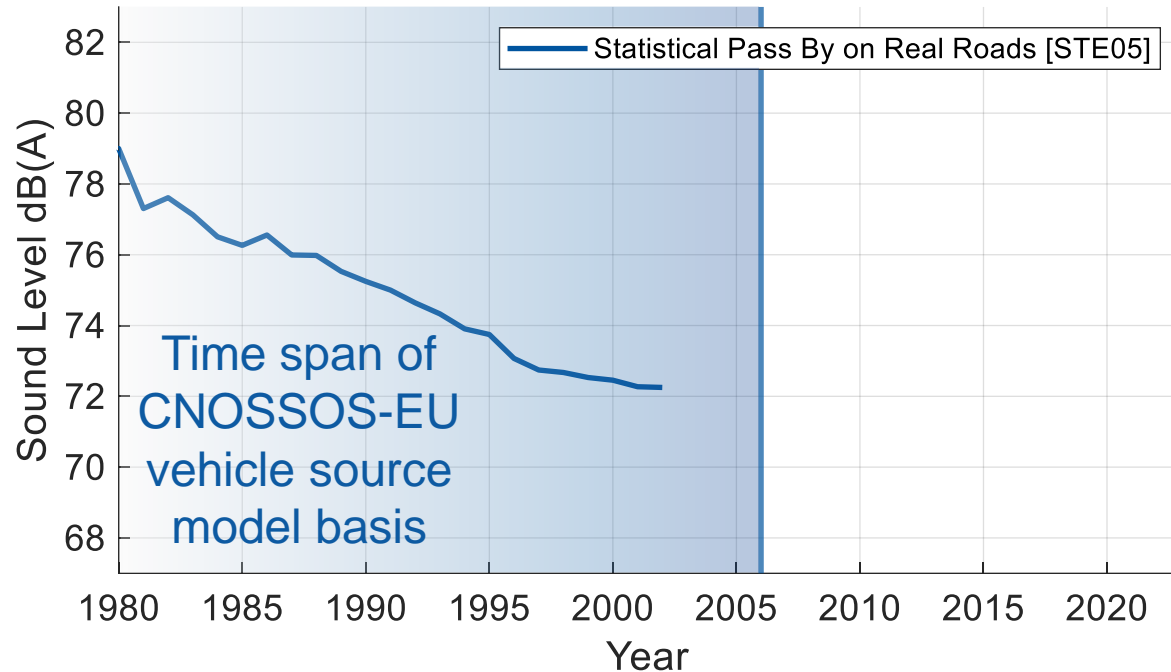

Additional information

- » Objective of [STE05]: Investigate efficiency of type approval limit changes
 - » Result: reduction in exterior noise
- » In 2001 and 2002 SPB measurements were conducted
 - » Plate numbers were recorded to reconstruct the year of each vehicles authorization
- » **CNOSSOS-EU** model is based on **vehicle fleets up to 200**

Suitable adaptations of the source description

Vehicle parameters regarding sound emission – Overall sound level

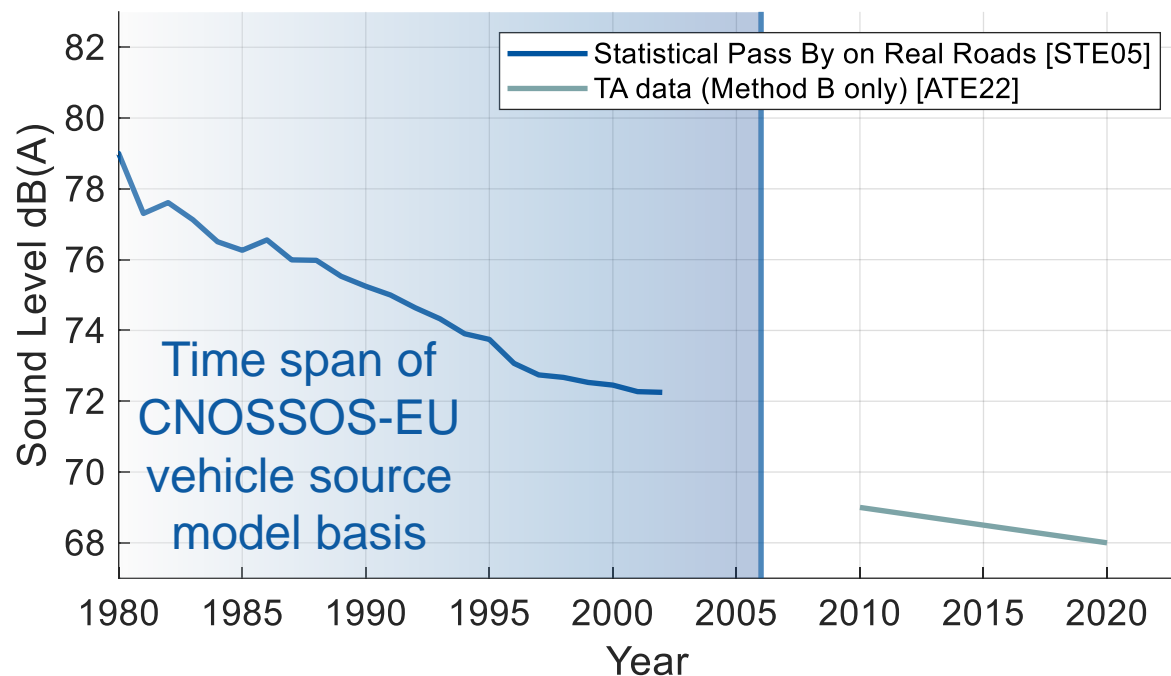

Additional information

- » Objective of [ATE22]: Investigate current type approval (TA) limits
 - » For this, 611 datasets from 2010 are compared to 1655 datasets from 2020 (all TA data)
- » [ATE22] only investigated TA method B which was introduced in 2016
 - » Vehicles of [STE05] campaigns are approved with TA method A
 - » Venoliva fitting for comparison between TA method A and method B [DER11]:
$$L_{B \rightarrow A} = L_B + 2.1 \text{ dB(A)}$$

Relevant vehicle parameters regarding sound emission

Overall Sound Level

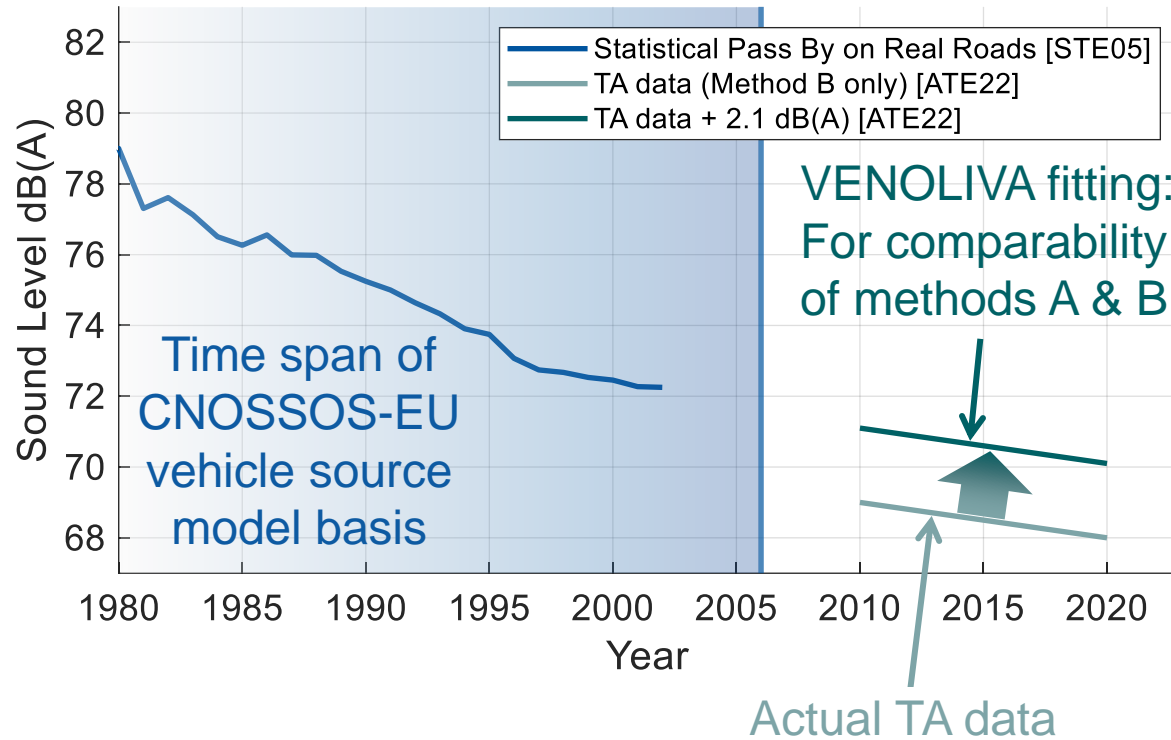

Additional information

- » Objective of [ATE22]: Investigate current type approval (TA) limits
 - » For this, **611 datasets from 2010** are compared to **1655 datasets from 2020** (all TA data)
- » [ATE22] only investigated TA method B which was introduced in 2016
 - » Vehicles of [STE05] campaigns are approved with TA method A
 - » Venoliva fitting for comparison between TA method A and method B [DER11]:
$$L_{B \rightarrow A} = L_B + 2.1 \text{ dB(A)}$$

Relevant vehicle parameters regarding sound emission

Overall Sound Level

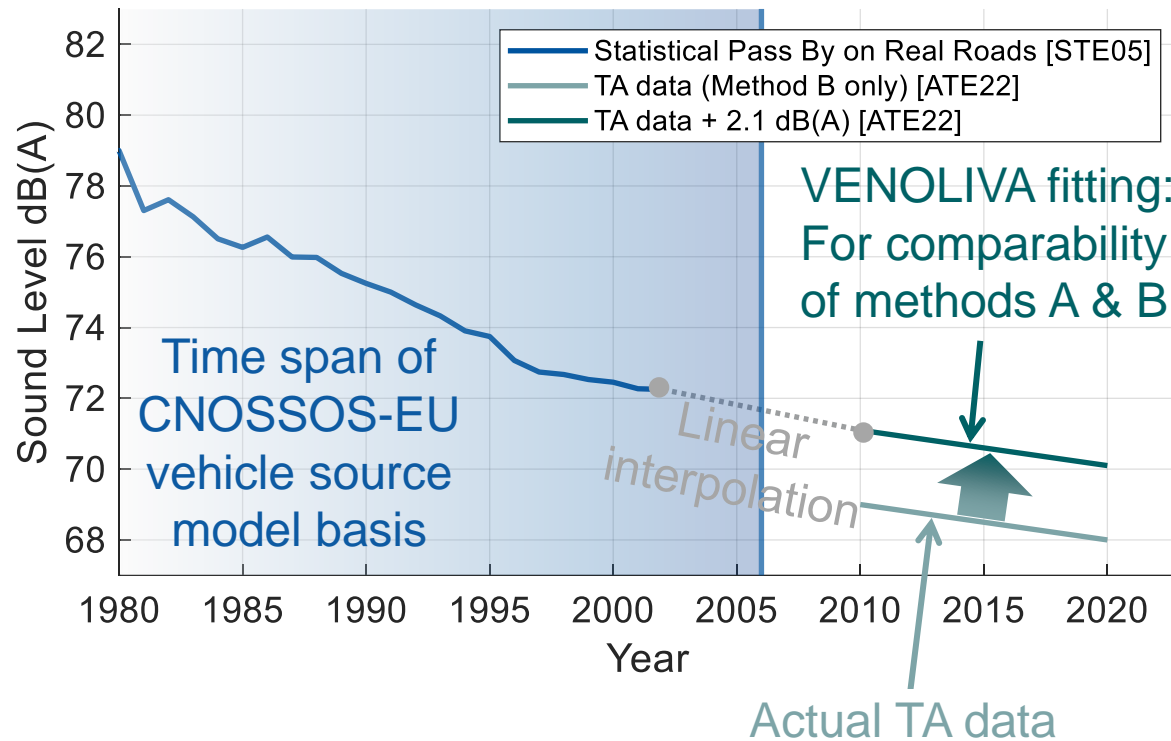

Additional information

- » **Linear interpolation** between 2002 data and 2010 data
- » For the time as of 2002, only **three data points** are available (2002, 2010, 2020)

Key message

Reduction in actual levels:

- » Data considered:
 - » Up to 2002 statistical pass-by measurements
 - » 2010-2020: TA data
- » Trend towards **decreasing values** can be seen

Relevant vehicle parameters regarding sound emission

Overall Sound Level

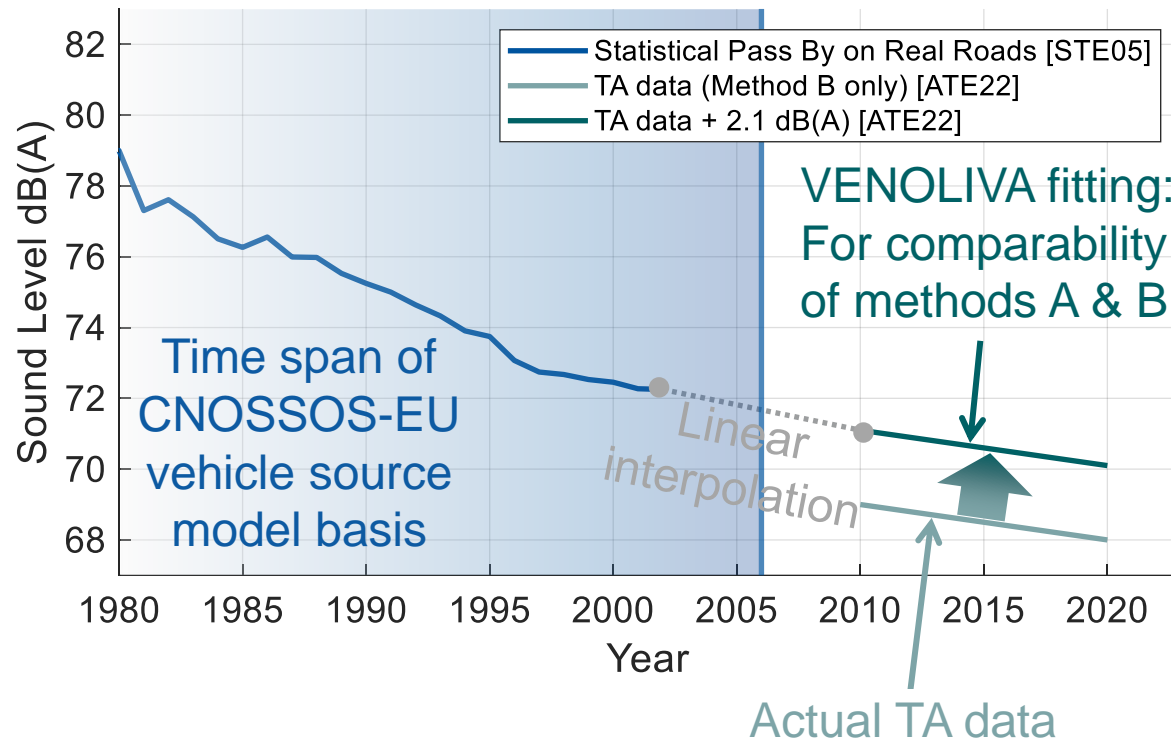

How can we compare the vehicle fleets?

Additional information

- » **Linear interpolation** between 2002 data and 2010 data
- » For the time as of 2002, only **three data points** are available (2002, 2010, 2020)

Key message

Reduction in actual levels:

- » Data considered:
 - » Up to 2002 statistical pass-by measurements
 - » 2010-2020: TA data
- » Trend towards **decreasing values** can be seen

Vehicle fleet comparison

- » From [STE05] an extraction from a vehicle fleet composition is possible based on the definition of a maximum vehicle age
- » For the following, two maximum vehicle ages are defined (for two different scenarios), namely
 - » 10 years
 - » 15 years
- » The cumulative composition can be seen in the figure on the right
 - » This is a fleet composition based on measurements in 2001/2002

Vehicle fleet composition obtained from [STE05]

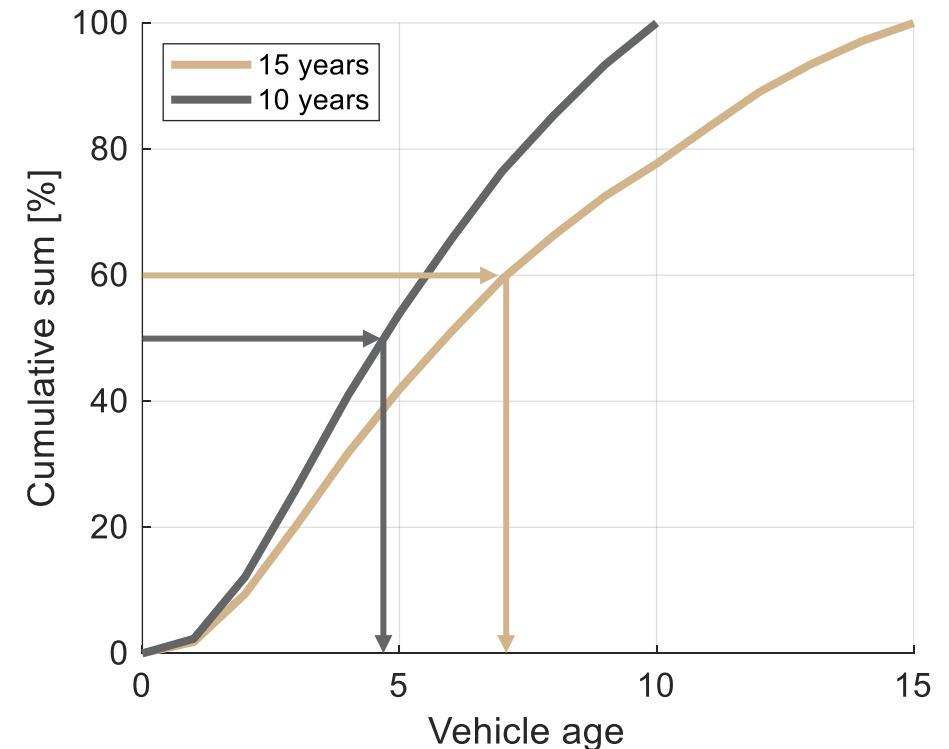

Examples

- » 10 year span: 50% of the vehicles are up to 4.8 years old
- » 15 year span: 60% of the vehicles are up to 7 years old

Vehicle fleet comparison

- » This fleet composition can be taken as a basis to compare the data provided in [STE05] with those from [ATE22]
- » Those two different fleet compositions (10 years and 15 years) are applied to the data shown before on the next slides

Vehicle fleet composition obtained from [STE05]

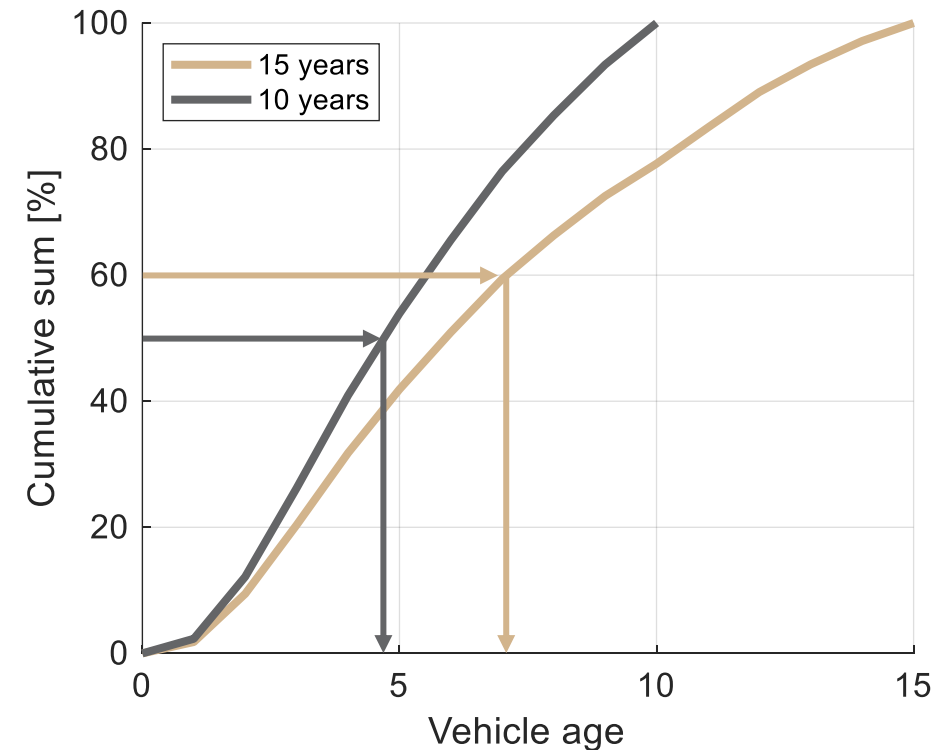

Examples

- » 10 year span: 50% of the vehicles are up to 4.8 years old
- » 15 year span: 60% of the vehicles are up to 7 years old

Relevant vehicle parameters regarding sound emission

Overall Sound Level

15 year span

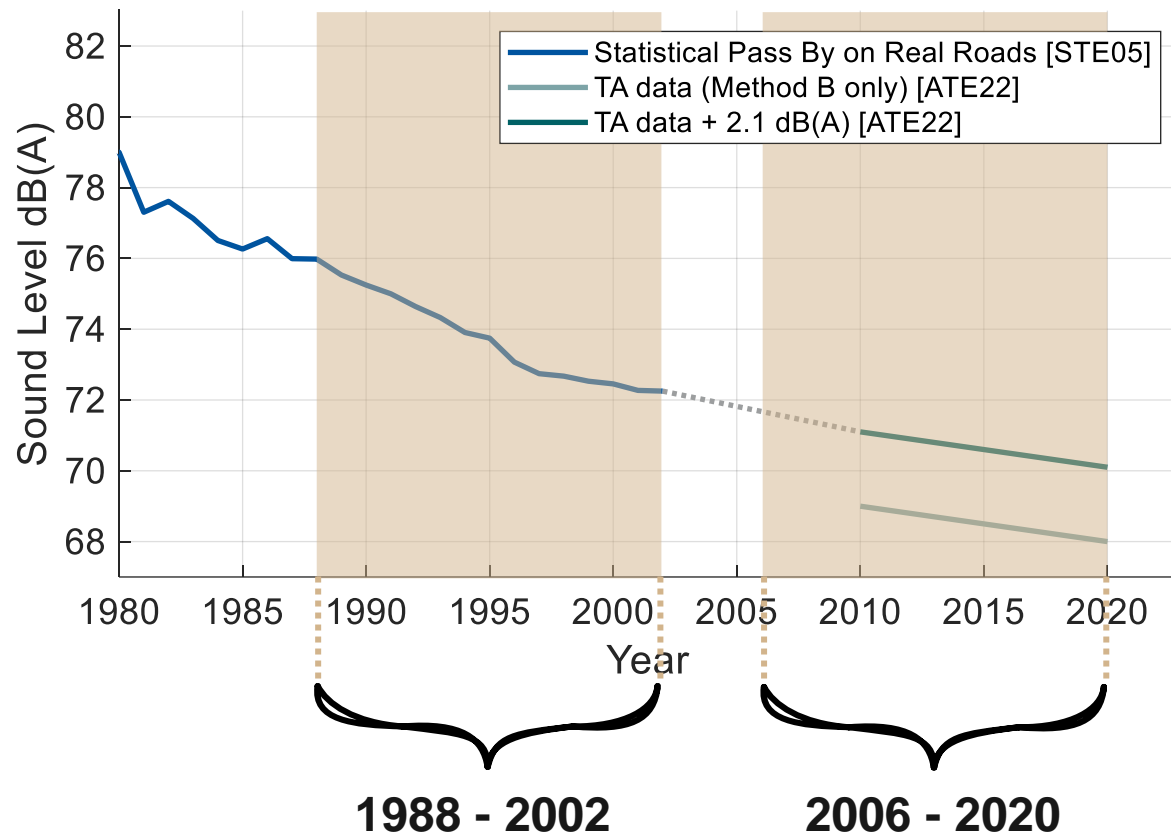

Vehicle fleet composition obtained from [STE05]

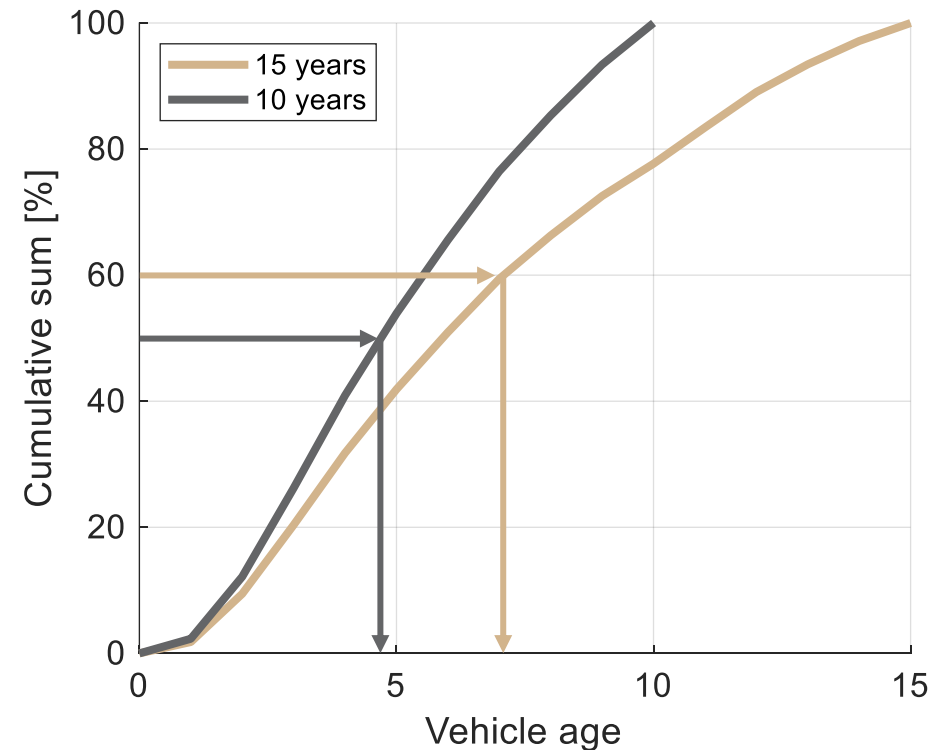

Examples

- » 10 year span: 50% of the vehicles are up to 4.8 years old
- » 15 year span: 60% of the vehicles are up to 7 years old

Relevant vehicle parameters regarding sound emission

Overall Sound Level



15 year span

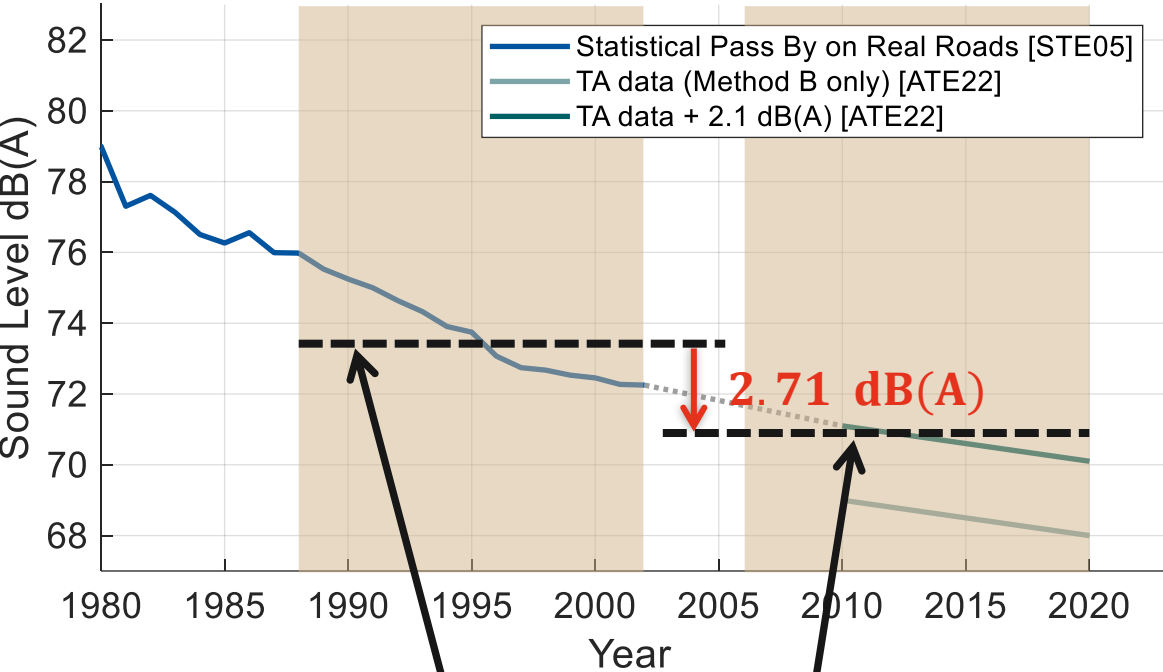

Study	$L_{A,mean}$
[STE05]	73.43 dB(A)
[ATE22] +2.1 dB(A)	70.72 dB(A)

Vehicle fleet composition obtained from [STE05]

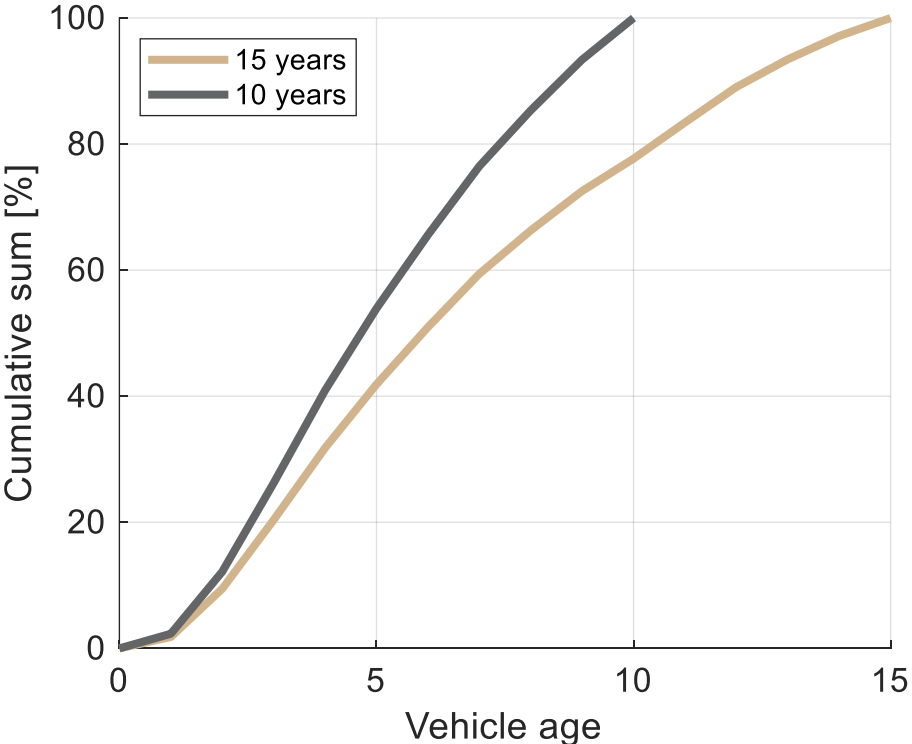

Relevant vehicle parameters regarding sound emission

Overall Sound Level

15 year span

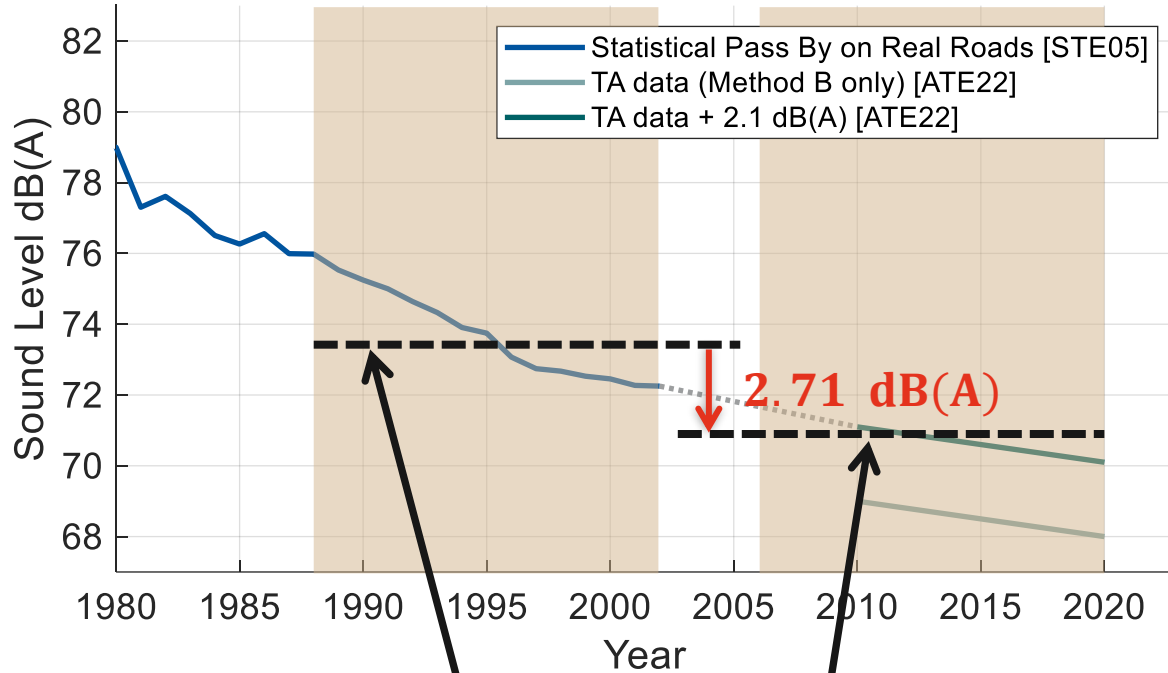

Study	$L_{A,mean}$
[STE05]	73.43 dB(A)
[ATE22] +2.1 dB(A)	70.72 dB(A)

-2.71 dB(A)

10 year span

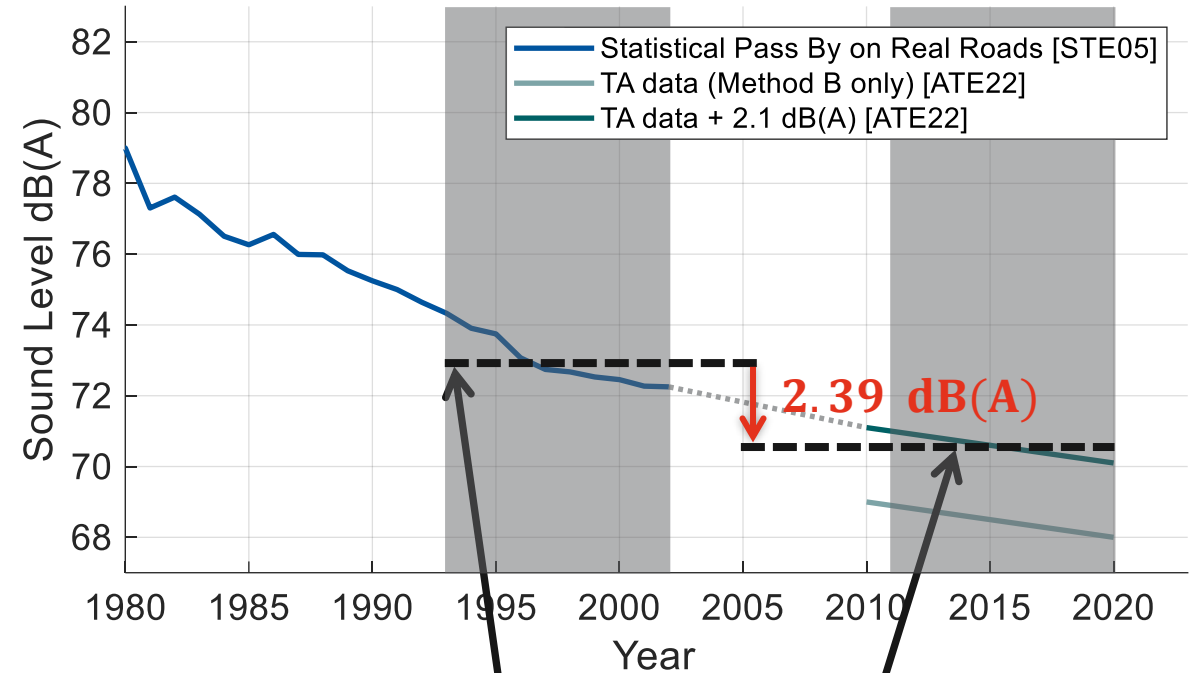

Study	L_A
[STE05]	72.93 dB(A)
[ATE22] +2.1 dB(A)	70.54 dB(A)

-2.39 dB(A)

Relevant vehicle parameters regarding sound emission

Overall Sound Level

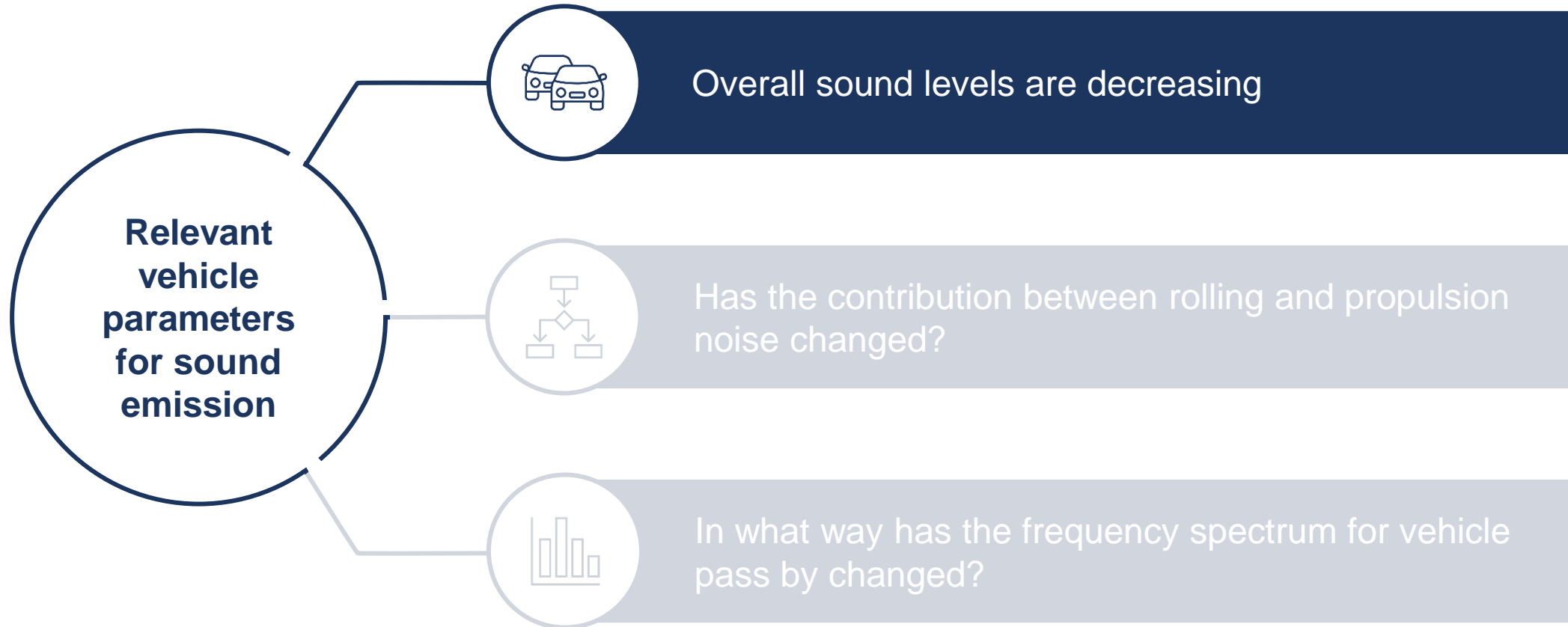

Relevant vehicle parameters regarding sound emission

Contribution of rolling and propulsion noise

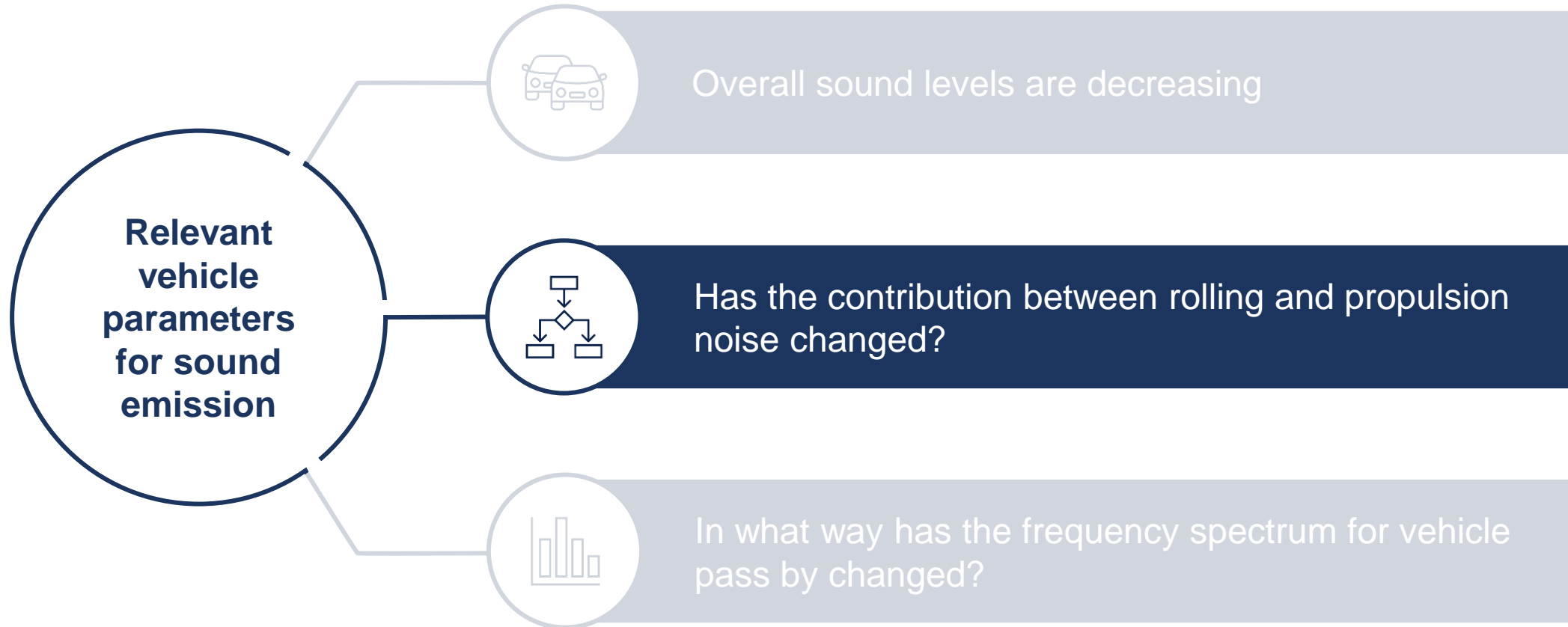

Relevant vehicle parameters regarding sound emission

Contribution of rolling and propulsion noise

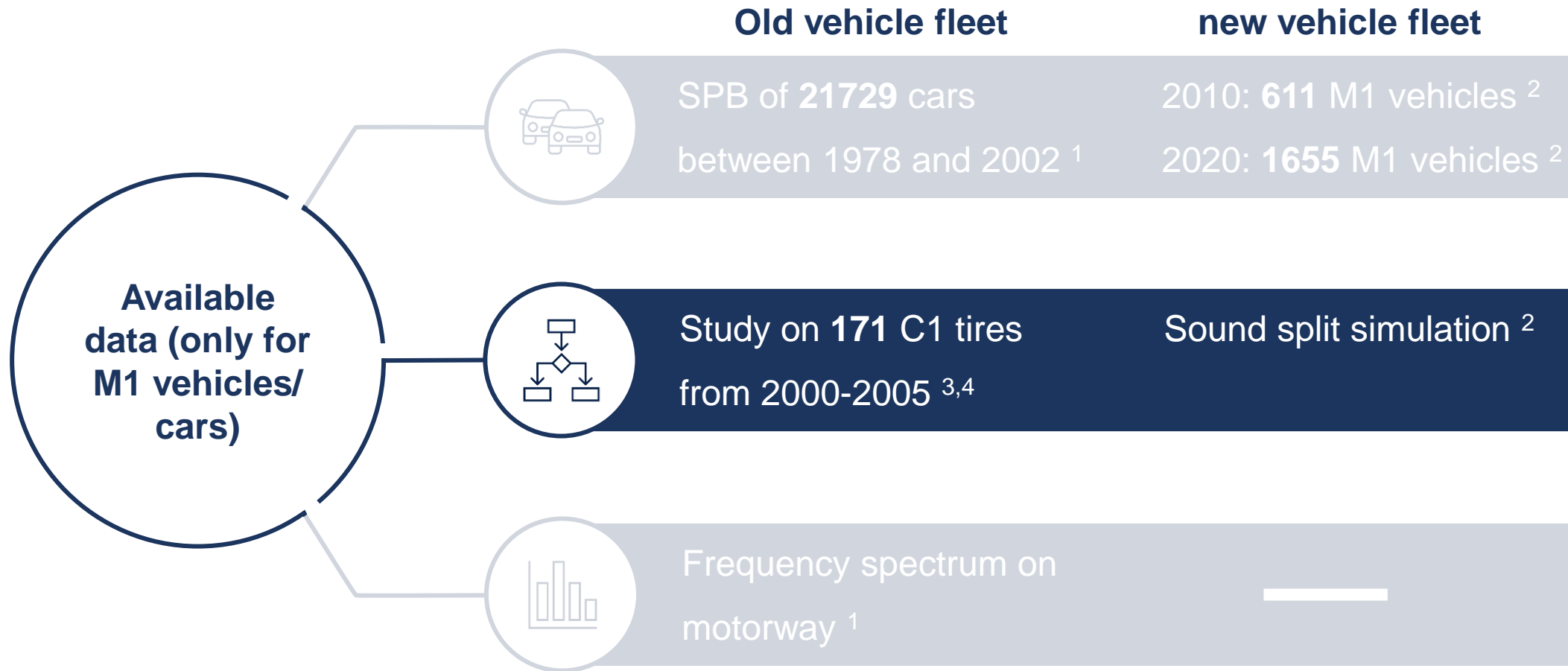

¹ [STE05]
² [ATE22]
³ [FER07]
⁴ [MOR03]

Relevant vehicle parameters regarding sound emission

Contribution of rolling and propulsion noise

Statistical distribution of L_{urban}

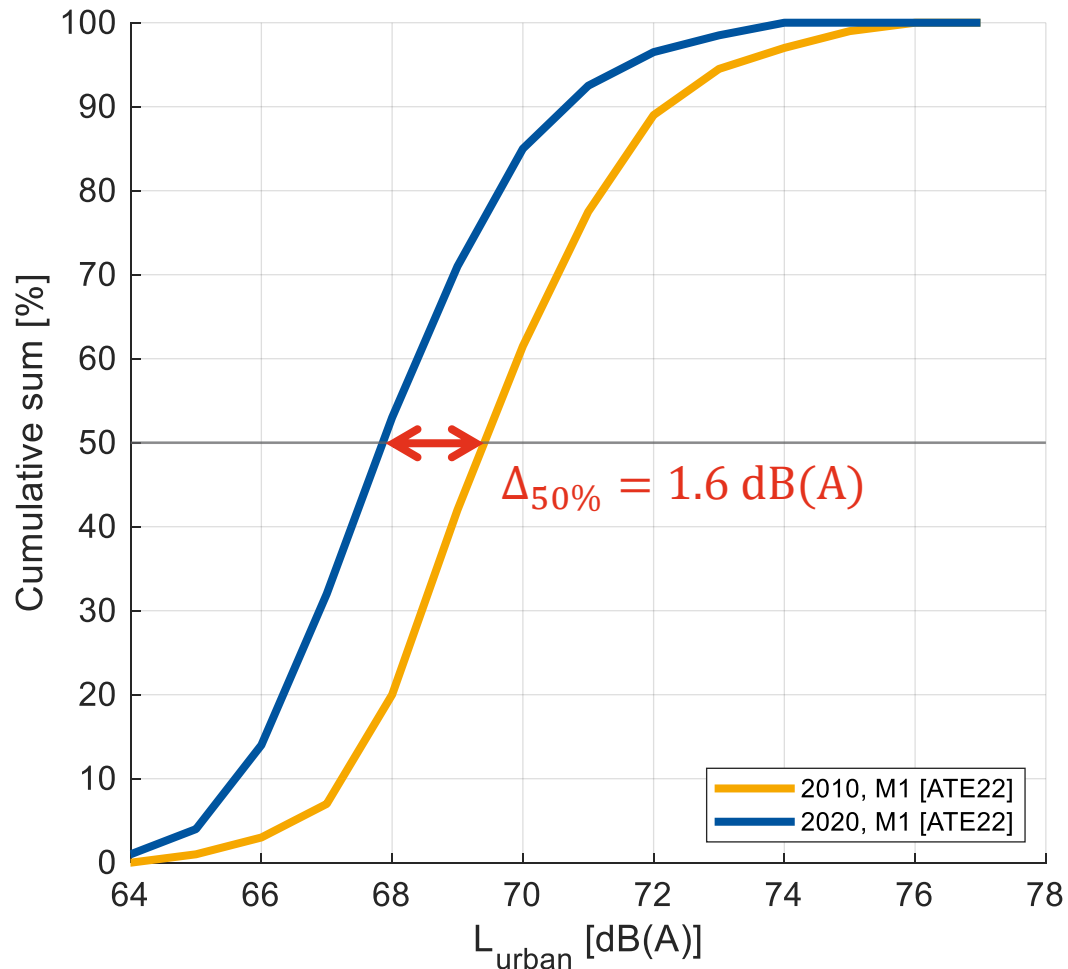

General information

- » In [ATE22], TA data of 2010 and 2020 are compared
- » The graph left shows the distribution of TA values (L_{urban}) for 2010 and 2020 cumulatively
- » Examples:
 - » 2010 (orange): 50% of the vehicles had an L_{urban} of $\sim 69.6 \text{ dB(A)}$ or less
 - » 2020 (blue): 50% of the vehicles had an L_{urban} of $\sim 68 \text{ dB(A)}$ or less
- » Reduction in L_{urban} from 2010 to 2020 of 1.6 dB(A)

Relevant vehicle parameters regarding sound emission

Contribution of rolling and propulsion noise

Statistical distribution of L_{urban}

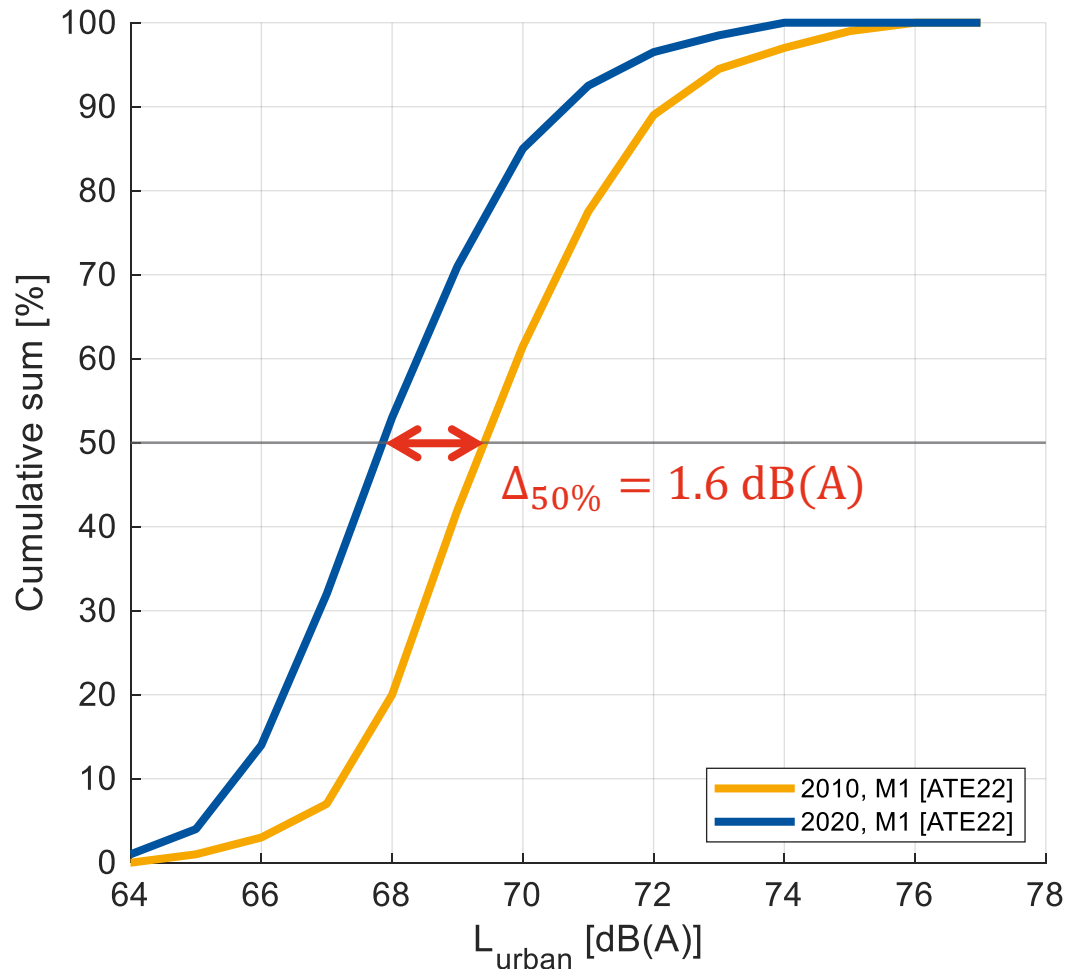

General information

- » In [ATE22], TA data of 2010 and 2020 are compared
- » The graph left shows the distribution of TA values (L_{urban}) for 2010 and 2020 cumulatively
- » L_{urban} results from a vehicle dependent factor (k_p) as well as constant (L_{crs}) and accelerated (L_{wot}) pass by measurements
 - »
$$L_{urban} = L_{wot\ rep} - k_p(L_{wot\ rep} - L_{crs\ rep})$$
- » Reduction in L_{urban} from 2010 to 2020 of **1.6 dB(A)** (median [1.553] and mean [1.559] value)

Relevant vehicle parameters regarding sound emission

Contribution of rolling and propulsion noise

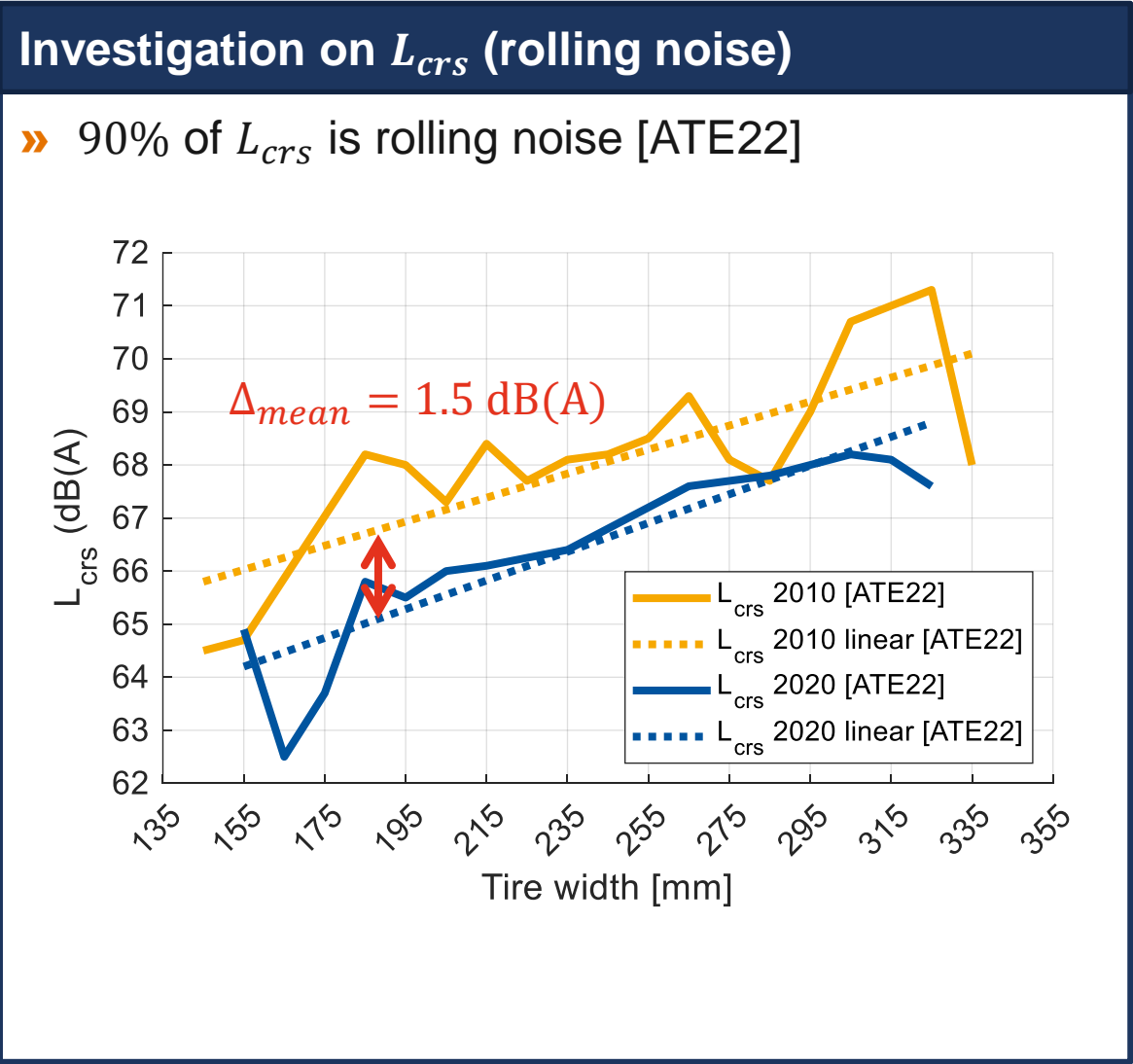
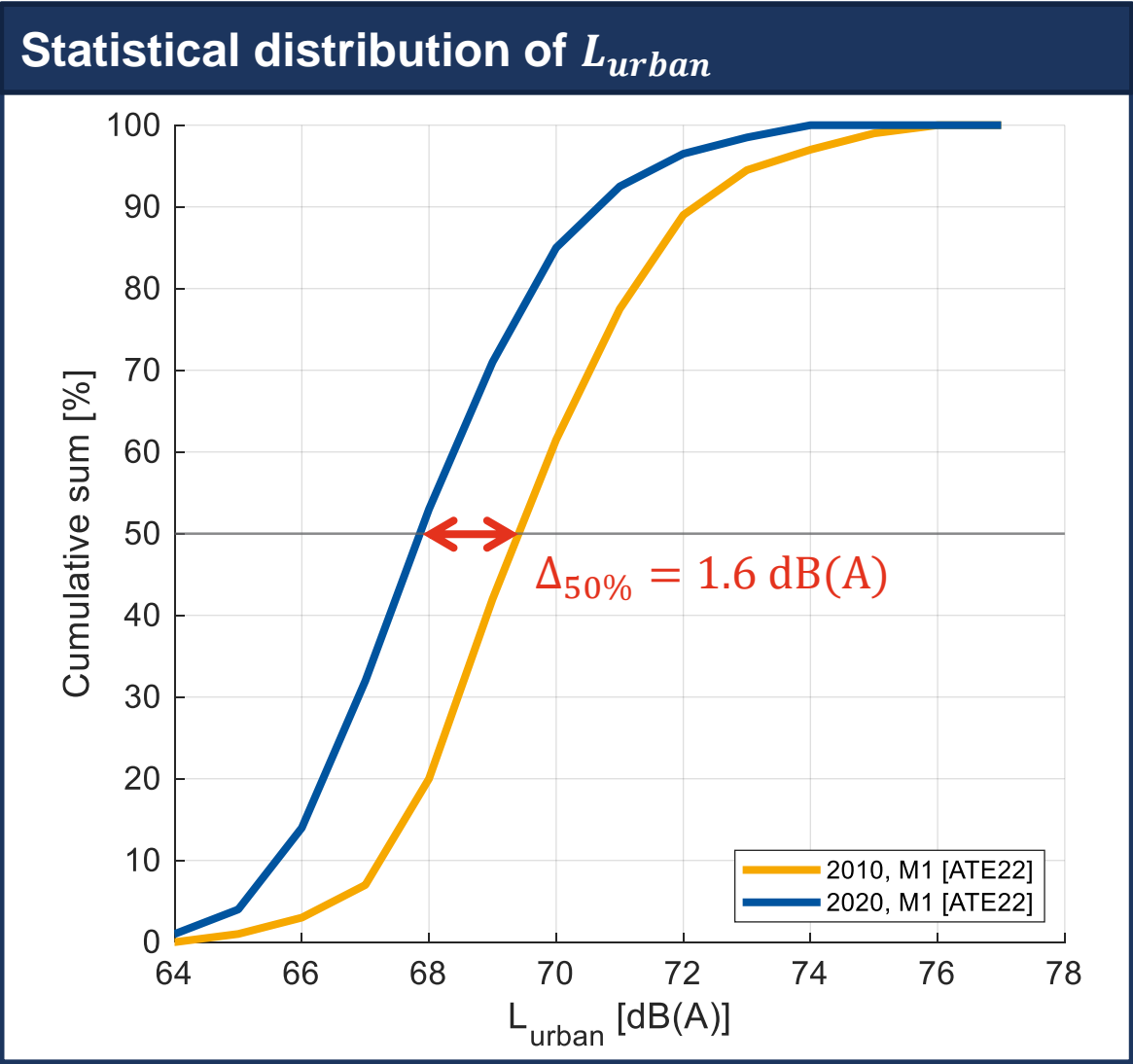

Relevant vehicle parameters regarding sound emission

Contribution of rolling and propulsion noise



Reductions from 2010 to 2020

» **1.6 dB(A) for L_{urban}**

» **1.5 dB(A) for L_{crs} (of which is 90 % rolling noise)**

Calculation of L_{urban}

» $L_{urban} = L_{wot rep} - k_p (L_{wot rep} - L_{crs rep})$

From 2010 to 2020 $\approx -1.6 \text{ dB(A)}$

$k_p = f(PMR)$

Reduction inevitable

From 2010 to 2020 $\approx -1.5 \text{ dB(A)}$

» **Indication of an unchanged contribution**

Relevant vehicle parameters regarding sound emission

Contribution of rolling and propulsion noise

Literature information

- » In [SHI15]:
 - » **Unchanged contribution** for rolling and propulsion noise is a good first estimate

might appear, but the engine noise may be ignored for light vehicles in these situations. As a first estimate it may be worthwhile to assume that the split between rolling and propulsion noise is in the same ratio as in the default CNOSSOS-EU database, provided that the appropriate asphalt type is provisionally used in the formula to help avoid the new values being a combination of vehicle and asphalt type changes.

Calculation of L_{urban}

$$L_{urban} = L_{wot rep} - k_p (L_{wot rep} - L_{crs rep})$$

From 2010 to 2020 $\approx -1.6 \text{ dB(A)}$

$k_p = f(PMR)$

From 2010 to 2020 $\approx -1.5 \text{ dB(A)}$

Reduction inevitable

- » **Indication** of an unchanged contribution
- » **Note:** The presented results do not deal with the topic of old vs. new vehicle fleets regarding the overall level (\rightarrow see meeting presentation no.10)

Relevant vehicle parameters regarding sound emission

Contribution of rolling and propulsion noise

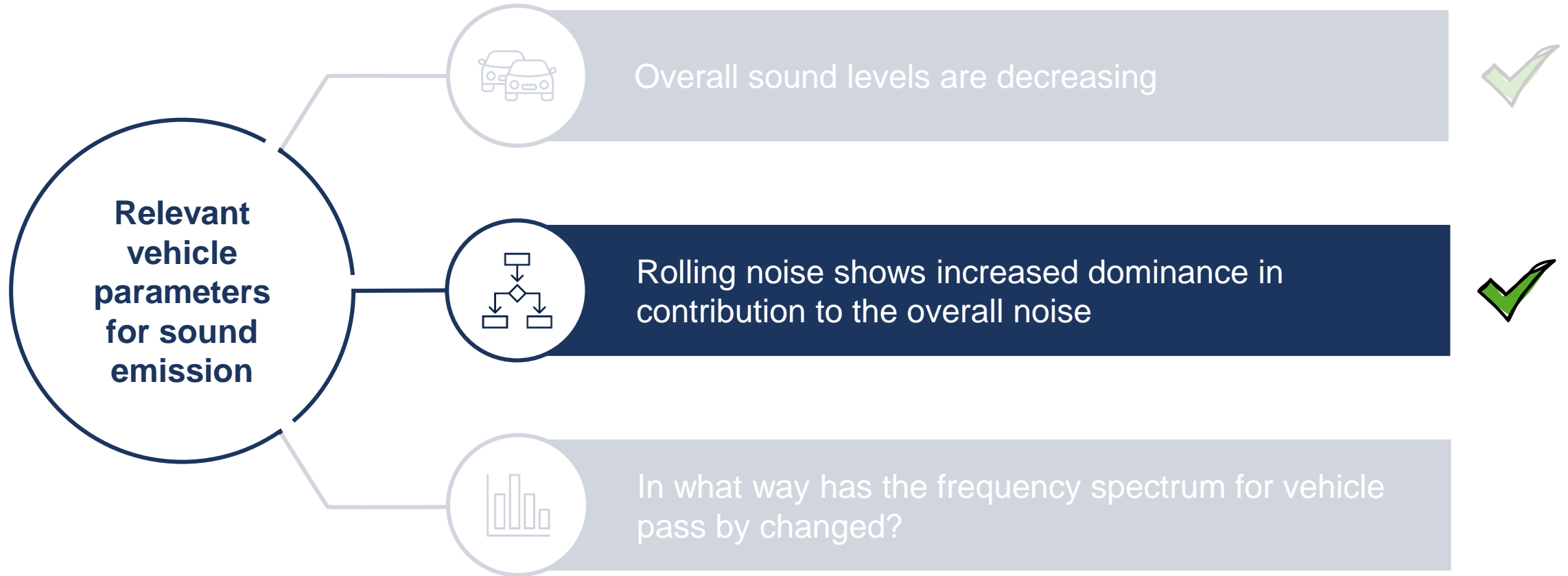

Relevant vehicle parameters regarding sound emission

Frequency spectrum

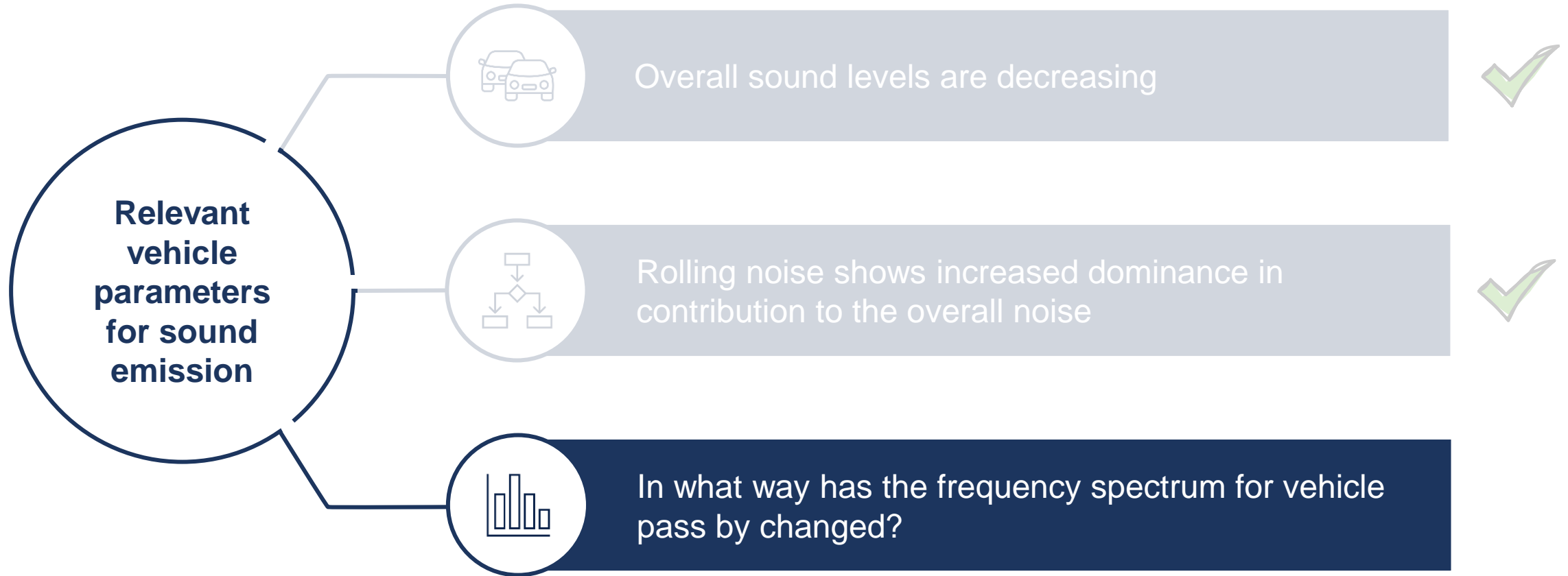

Relevant vehicle parameters regarding sound emission

Frequency spectrum

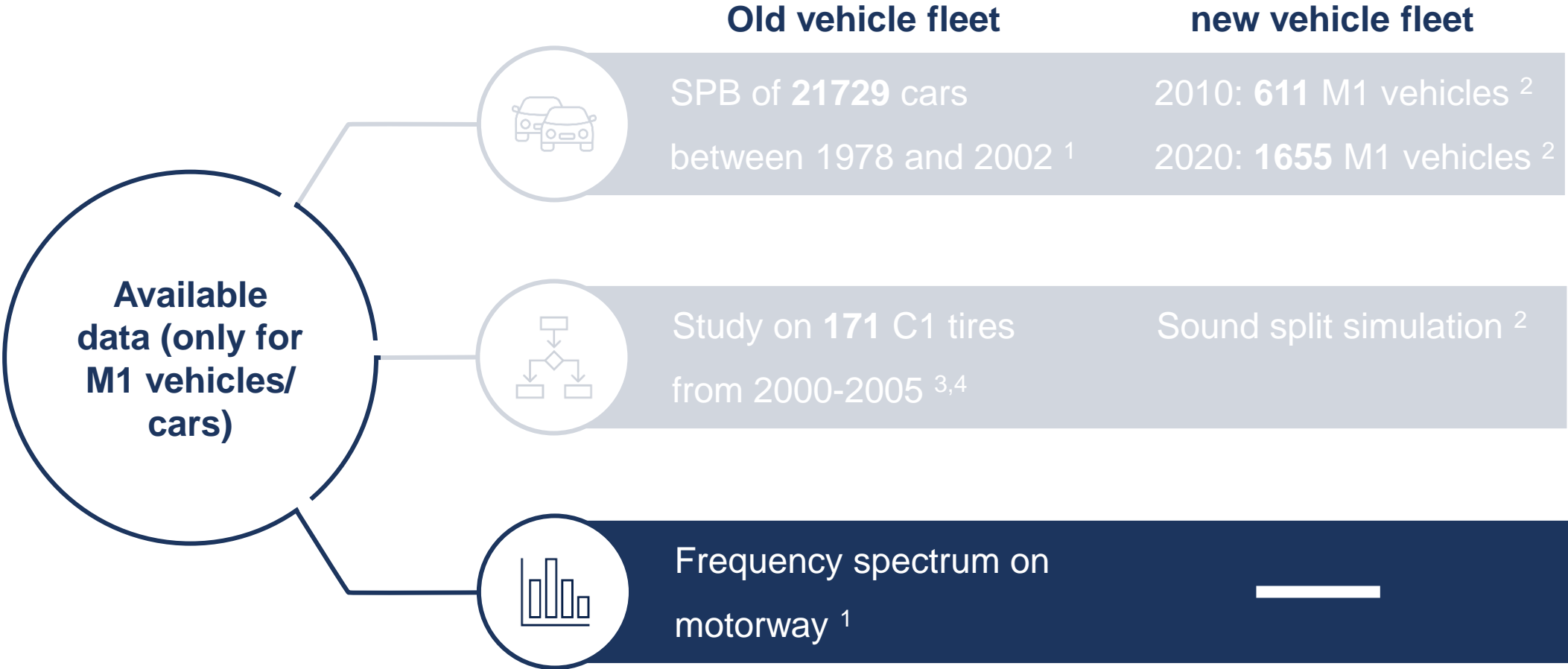

¹ [STE05]
² [ATE22]
³ [FER07]
⁴ [MOR03]

Investigations in [STE05]

- » In [STE05], **frequency spectrums on motorways** are investigated
 - » e.g. averaged frequency distribution [STE05]:

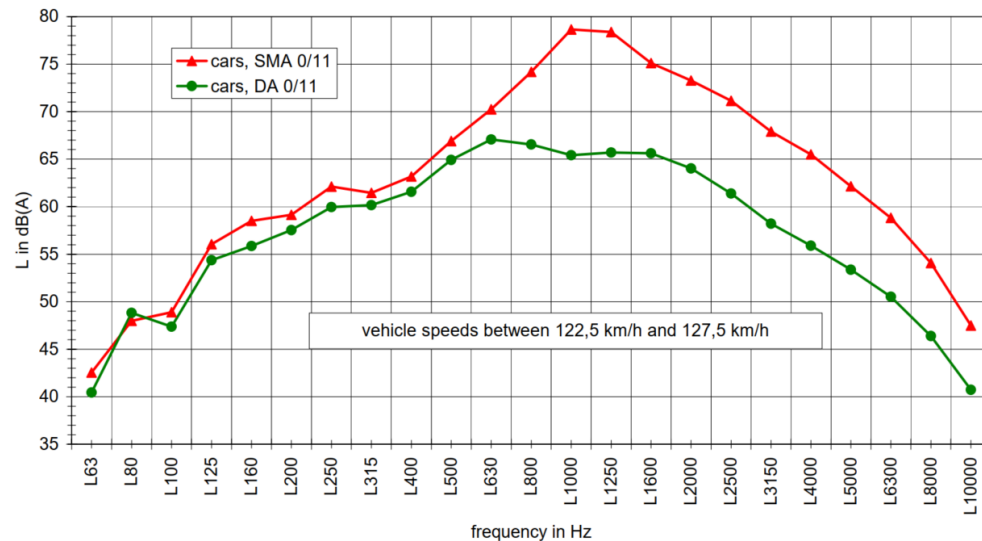

- » Frequency data for other types of roads is also unavailable in [STE05]

General information

- » **Not enough data available** for an investigation of possible changes in the frequency spectrum of pass by vehicles
- » A reasonable first assumption could be that the **frequency distribution remains unchanged** when considering the same sources (ICE & tire-road noise) due to the lack of data
 - » This could be investigated in an extensive EU project for updating the coefficients

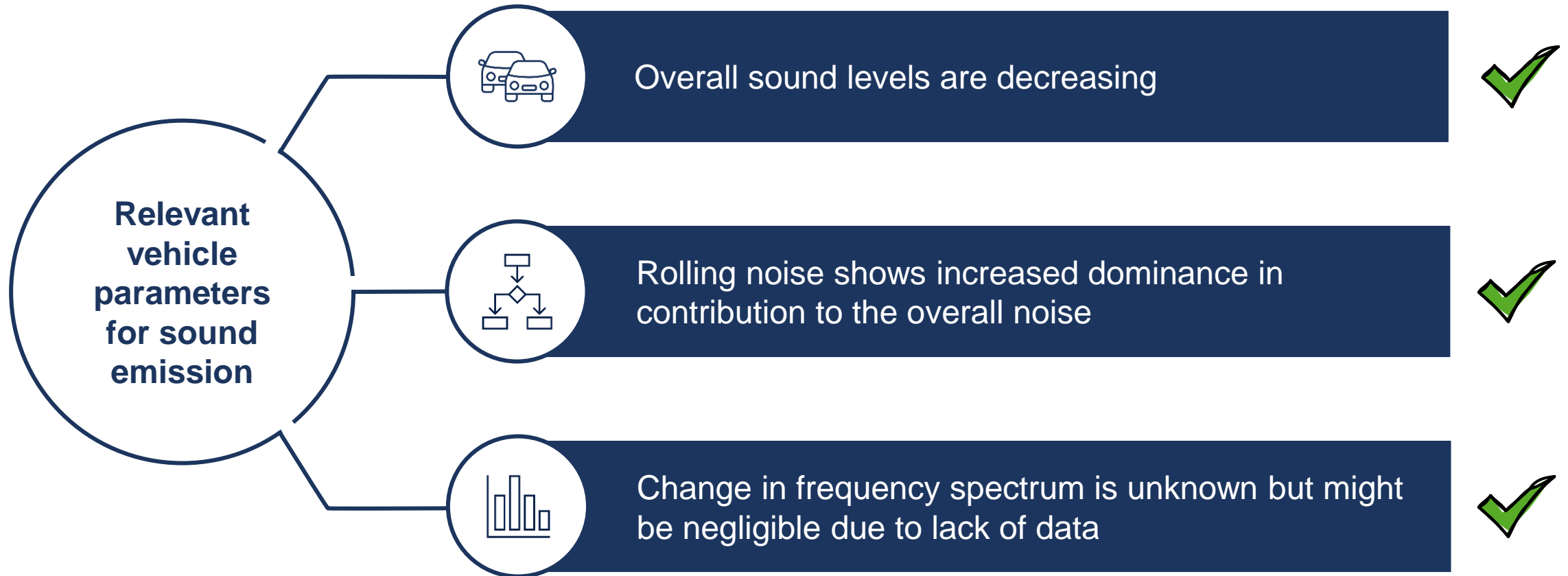

Suitable adaptations of the source description

Key questions/ tasks within work package 2.3

1. Overview on relevant vehicle parameters regarding sound emission
2. Overview on relevant changes in legislative boundary conditions
3. Determination of possibilities for integration into existing models

Type Approvals, Method A + B

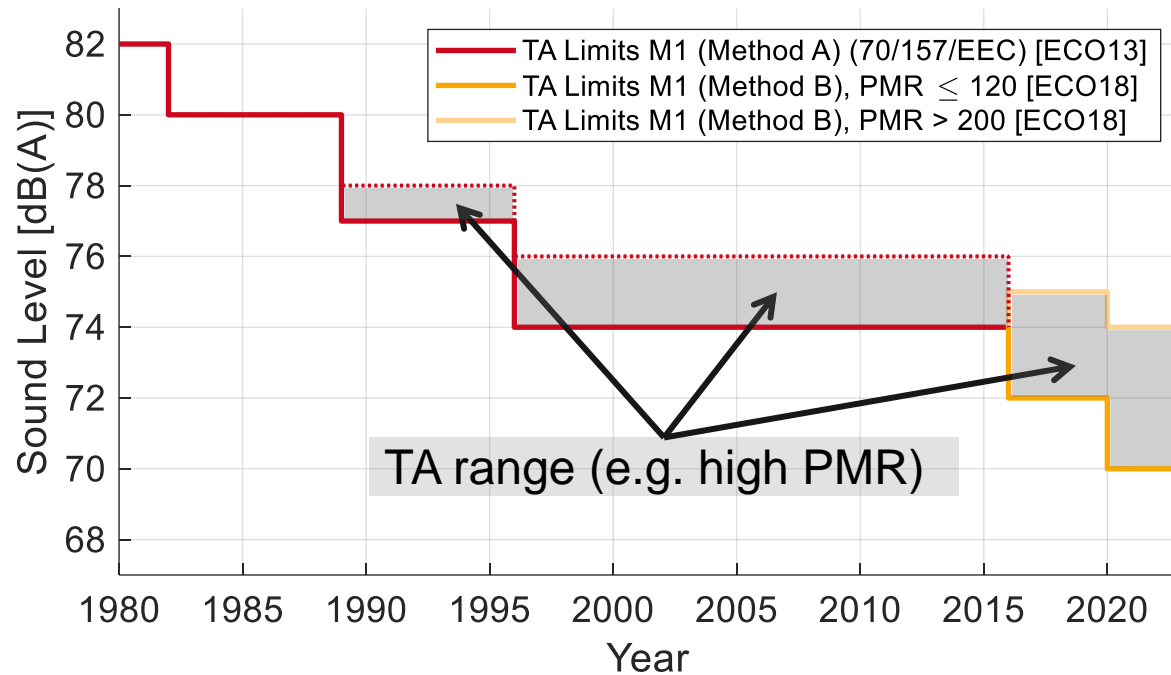

Additional information

- » From 2016 on, a new type approval method was introduced (Method B)
 - » Method A: only accelerated maneuvers
 - » Method B: accelerated and constant speed maneuvers

Key message

- » **Legal limits** regarding vehicle noise emission **decreased** significantly over the years

Type Approvals, Method A + B

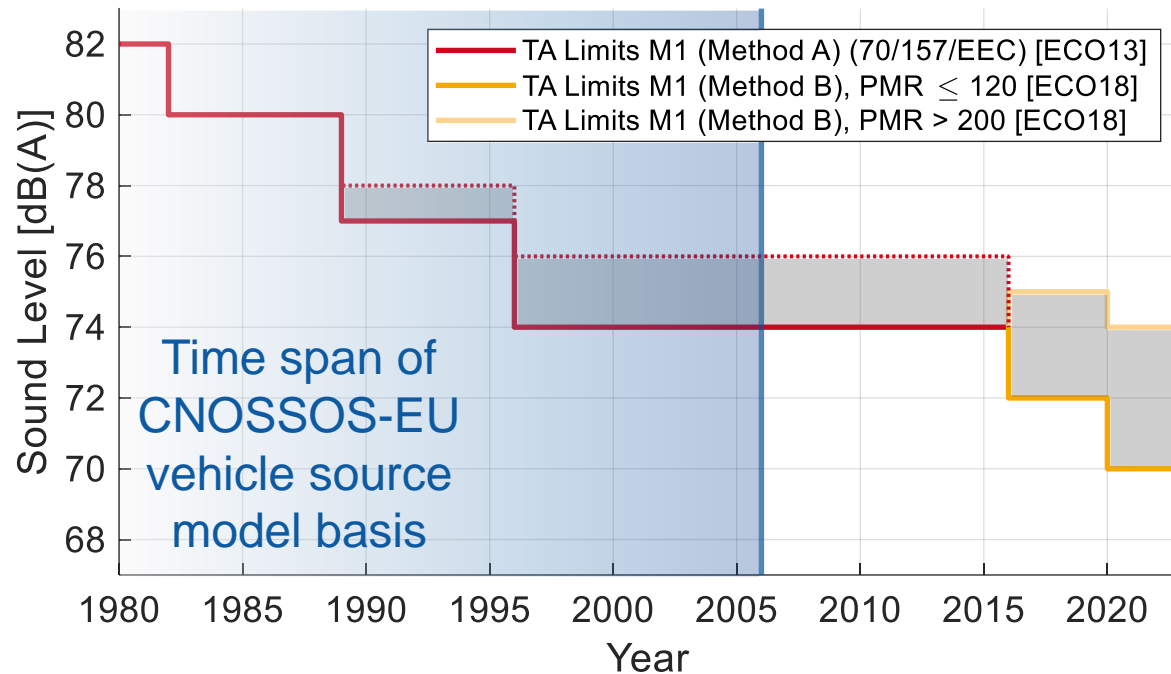

Additional information

- » From 2016 on, a new type approval method was introduced (Method B)
 - » Method A: only accelerated maneuvers
 - » Method B: accelerated and constant speed maneuvers

Key message

- » **Legal limits** regarding vehicle noise emission **decreased** significantly over the years
- » **CNOSSOS-EU** model is based on **vehicle fleets up to 2006**

Type Approvals, Method A + B

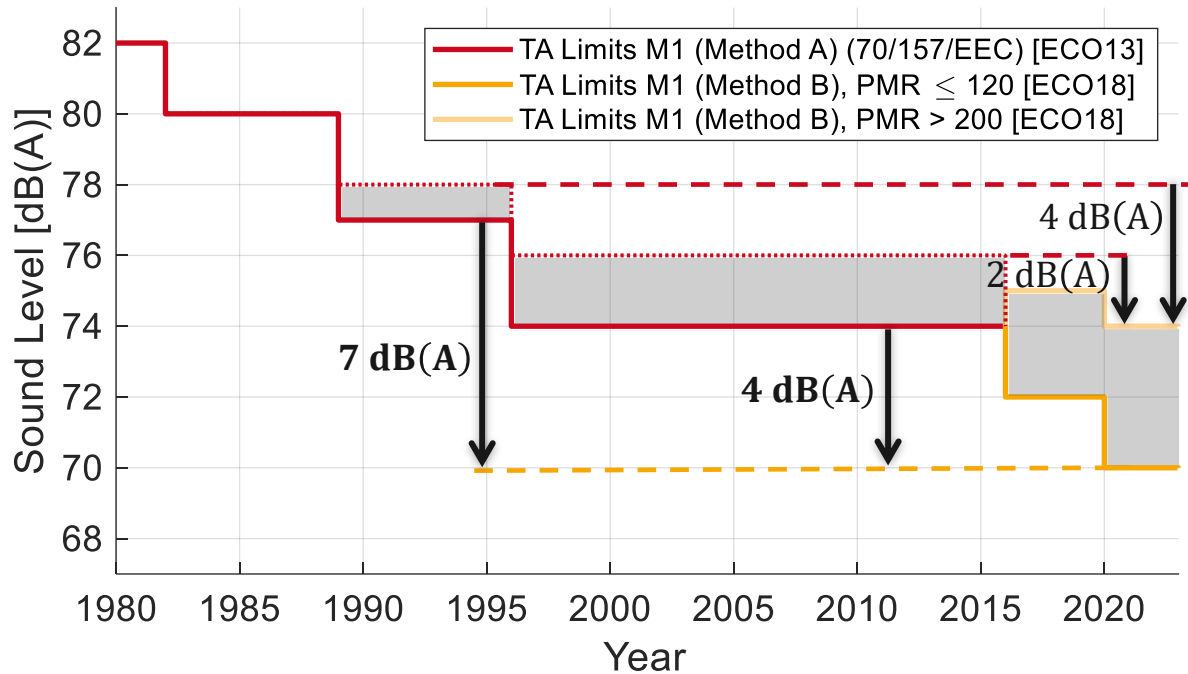

Additional information

- » From 2016 on, a new type approval method was introduced (Method B)
 - » Method A: only accelerated maneuvers
 - » Method B: accelerated and constant speed maneuvers

Key message

Reduction in TA limits:

- » “Common” vehicles
 - » 1995 → 2021: -7 dB(A)
 - » 2006 → 2021: -4 dB(A)
- » “High performance” vehicles
 - » 1995 → 2021: -4 dB(A)
 - » 2006 → 2021: -2 dB(A)

Suitable adaptations of the source description

Key questions/ tasks within work package 2.3

1. Overview on relevant vehicle parameters regarding sound emission
2. Overview on relevant changes in legislative boundary conditions
3. Determination of possibilities for integration into existing models

Possibilities for integrating sound emission changes

CNOSSOS-EU Category extension

Literature review on [SHI15] & [DEV]

- » A procedure is described on how to adapt/extent the vehicle categories:
 - » Category ID (≥ 5)
 - » Description
 - » Rolling noise (yes/no)
 - » Propulsion noise (yes/no)
 - » Corrections (Studded tires, air temperature, gradient)
 - » Speed variations
 - » Coefficients for acceleration $C_{r,k}$ & $C_{p,k}$
 - » Coefficients $A_{R,i,m}$, $B_{R,i,m}$, $A_{P,i,m}$ & $B_{P,i,m}$

Cat.	Name
1	Light motor vehicles
2	Medium heavy vehicles
3	Heavy vehicles
4	Powered two-wheelers
5	Open category
...	New categories

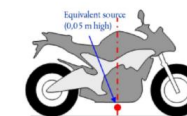
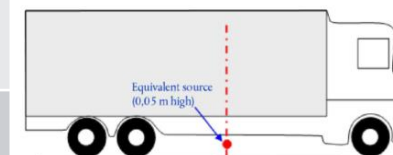
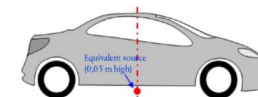

Possibilities for integrating sound emission changes

Determination of new coefficients

General information [SHI15] [DEV] [IMA07a]

- » Required measurements: Vehicle pass-by as conducted by TNO / within IMAGINE
 - » Sound emission levels (SEL)
- » There is no standardized method on the derivation of the coefficients
- » However, a procedure is presented in [SHI15] [DEV]
 - » General driving conditions:
 - » Constant speed (multiple speeds)
 - » Accelerating/decelerating
 - » Uphill/downhill
 - » SPB Measurements (information on SPB from **slide 45-47 and 147-155**)

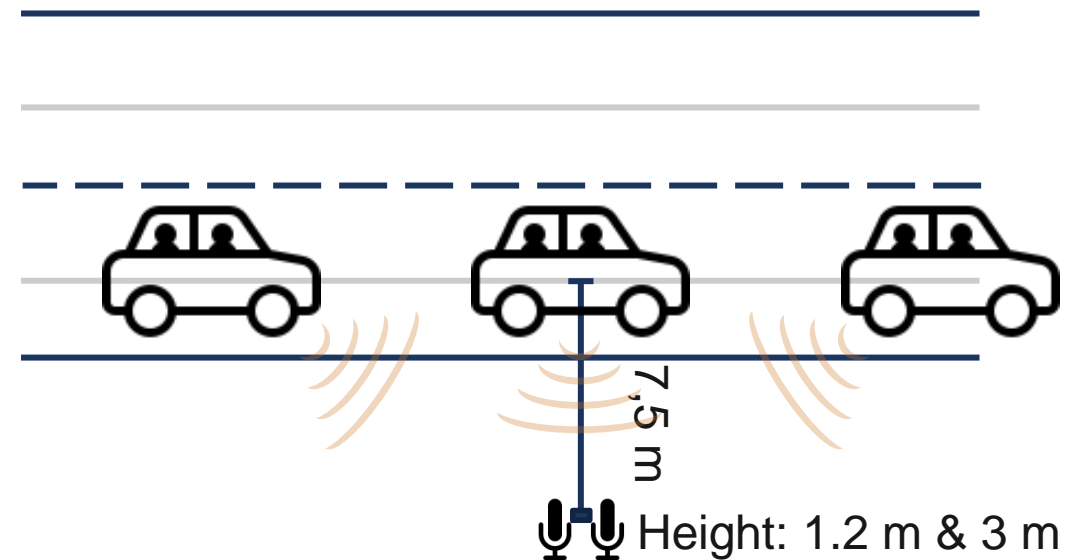

Possibilities for integrating sound emission changes

Determination of new coefficients

Coefficient estimation [SH15] [DEV]

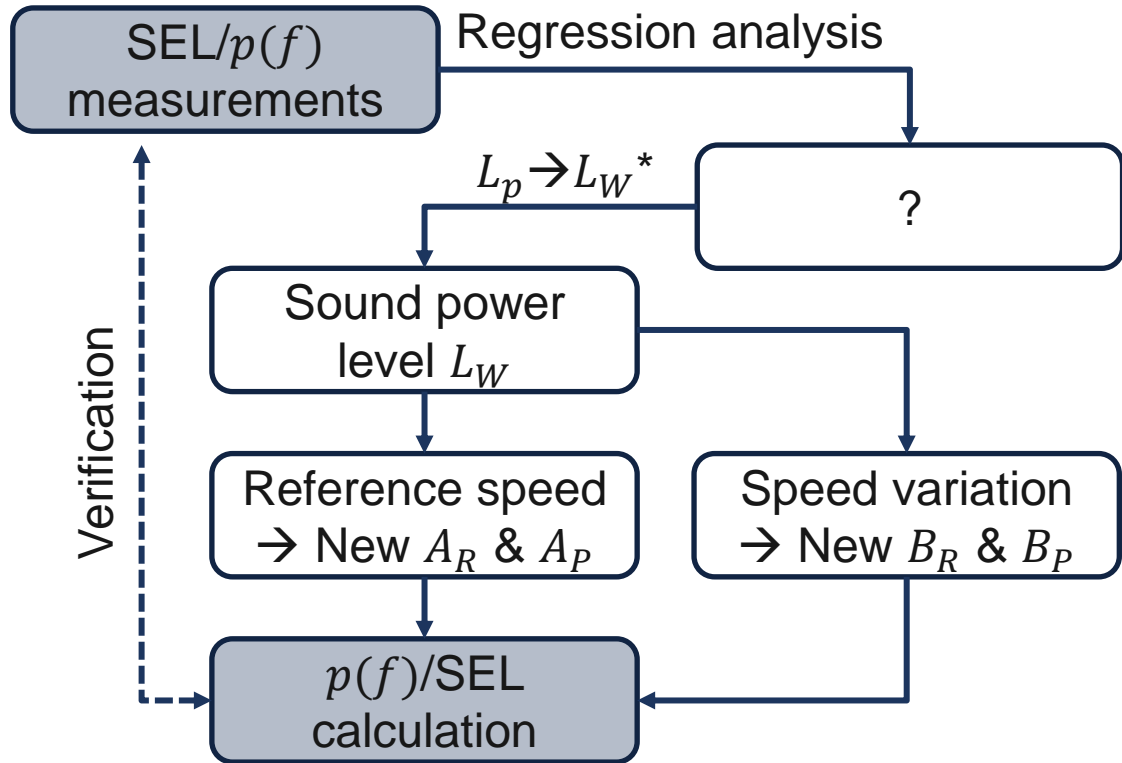

*Conversion from sound pressure level L_p to sound power level L_W considering directivity & mic. position

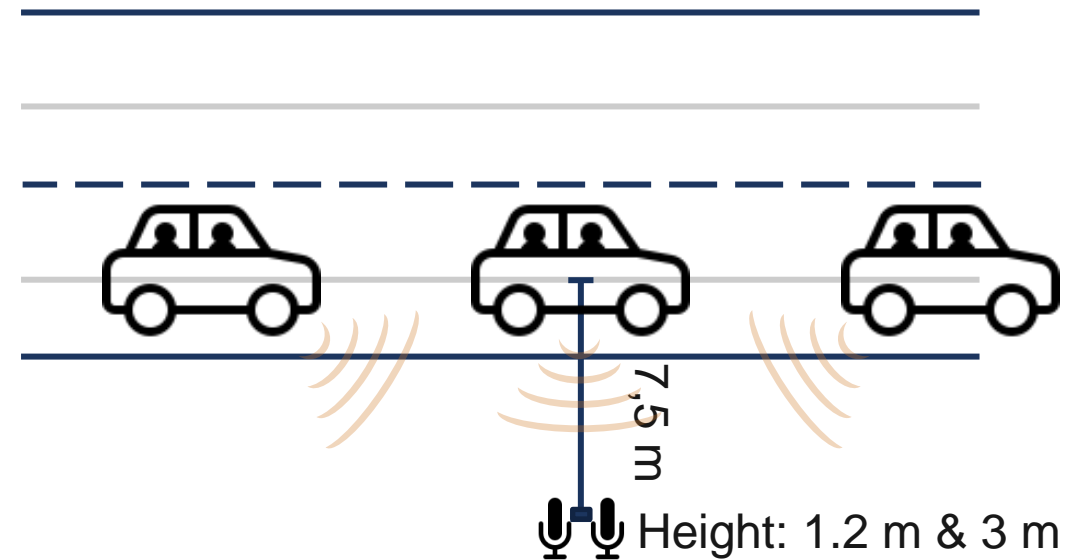

Possibilities for integrating sound emission changes

Determination of new coefficients

Coefficient estimation [SH15] [DEV]

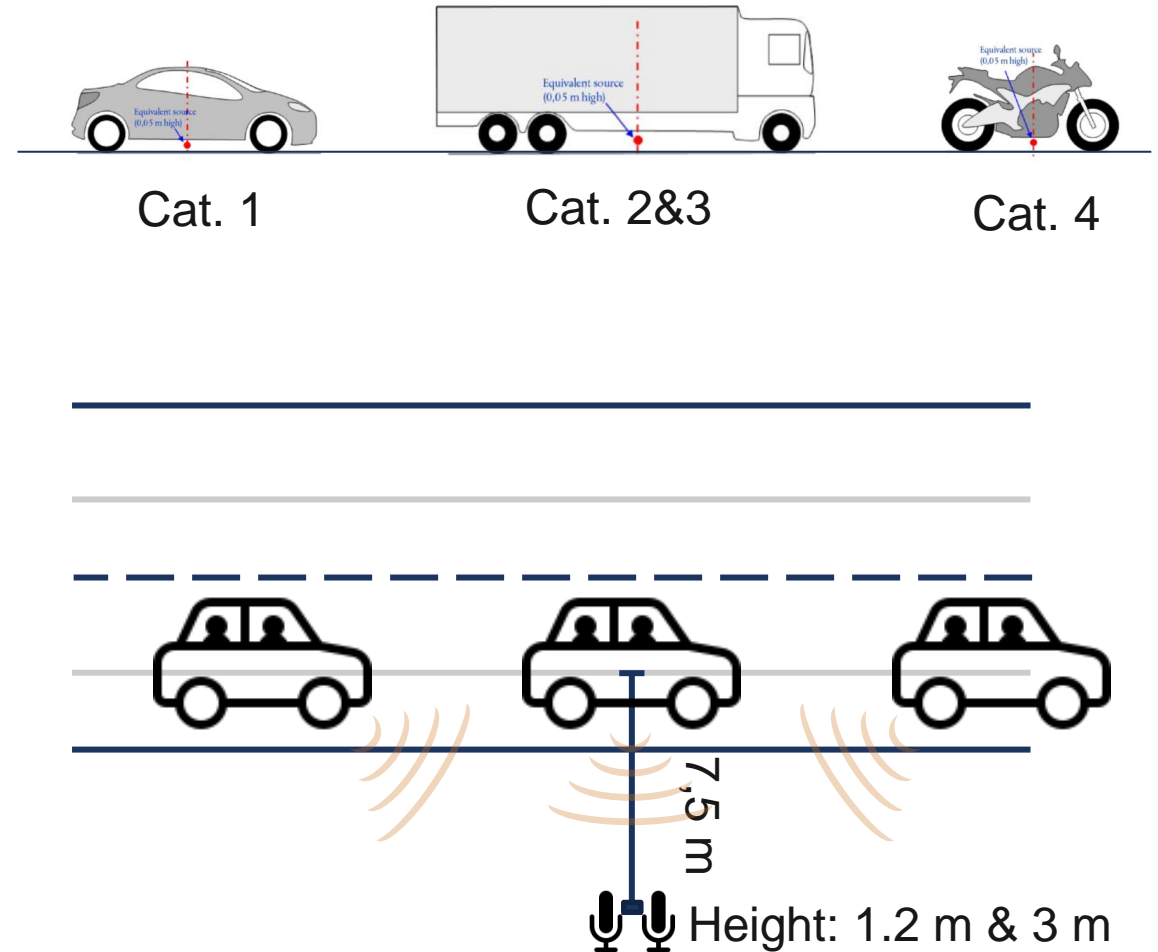
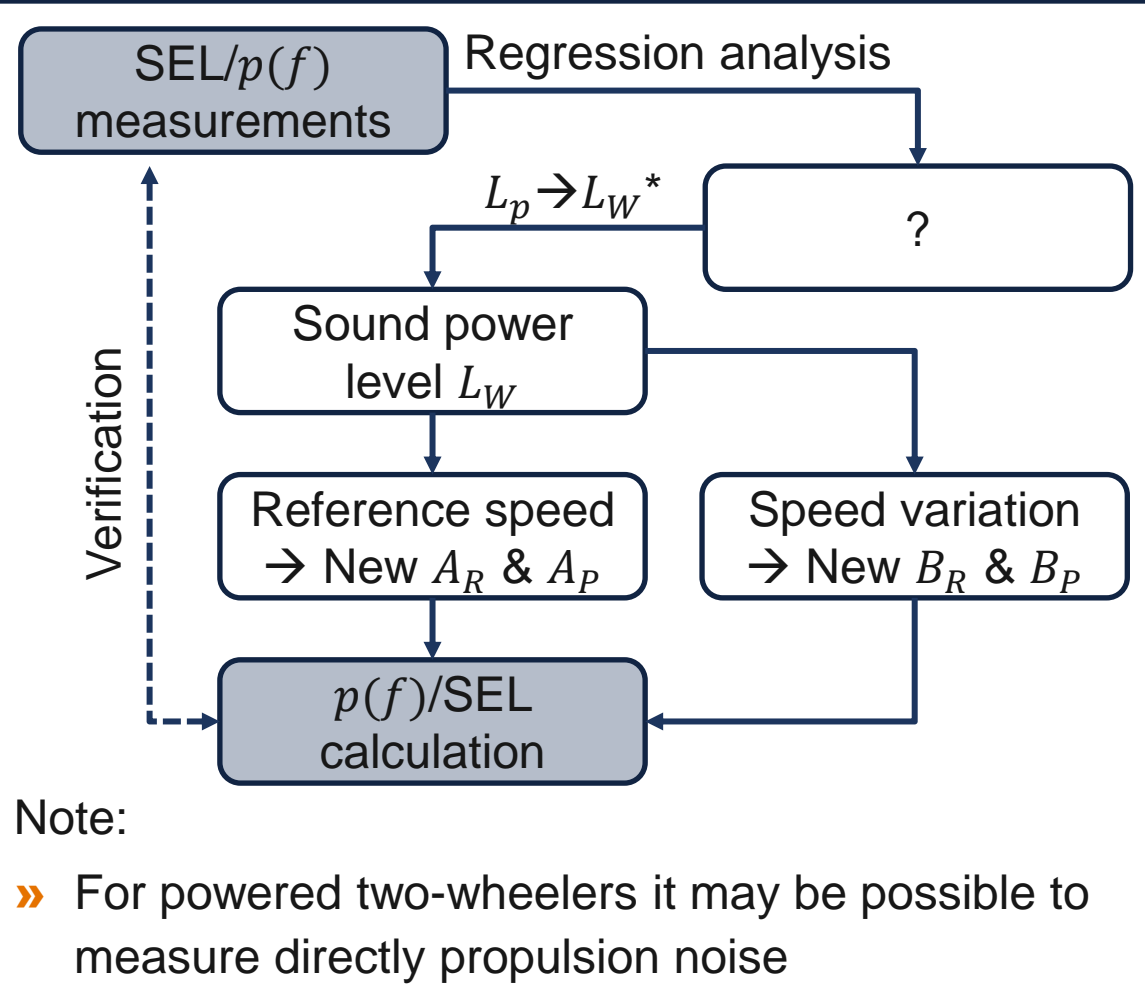

Possibilities for integrating sound emission changes

Determination of new coefficients

Coefficient estimation [SHI15] [DEV]

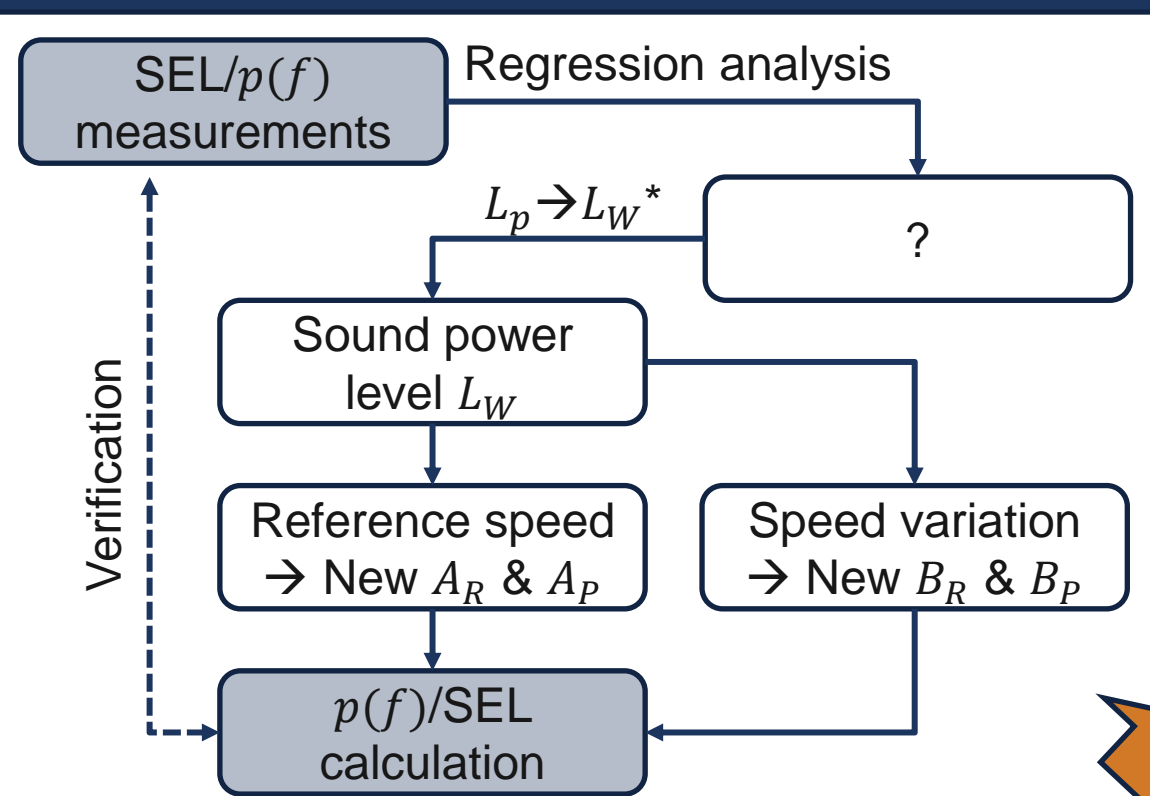

Note:

- » For powered two-wheelers it may be possible to measure directly propulsion noise

Procedure described in [SHI15]

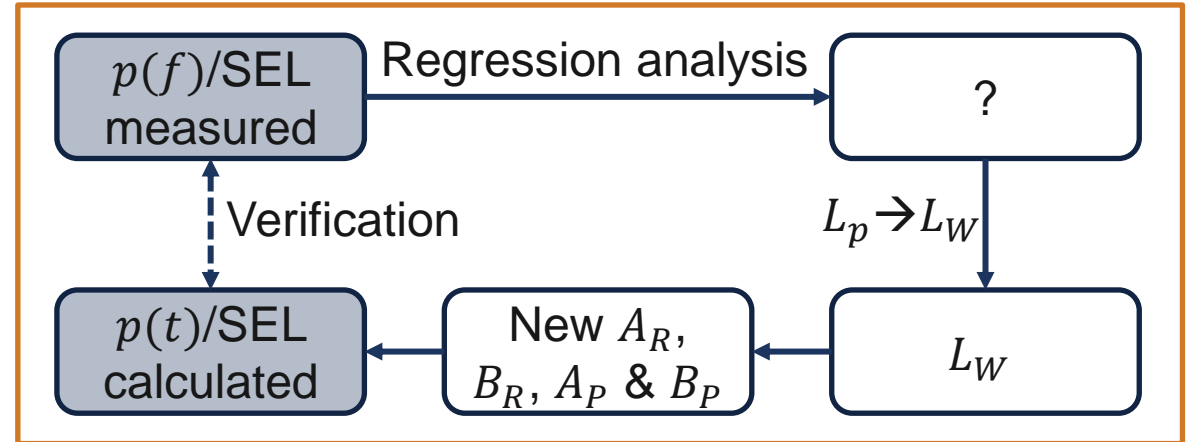

Mathematically comprehensible based on [WAT04]

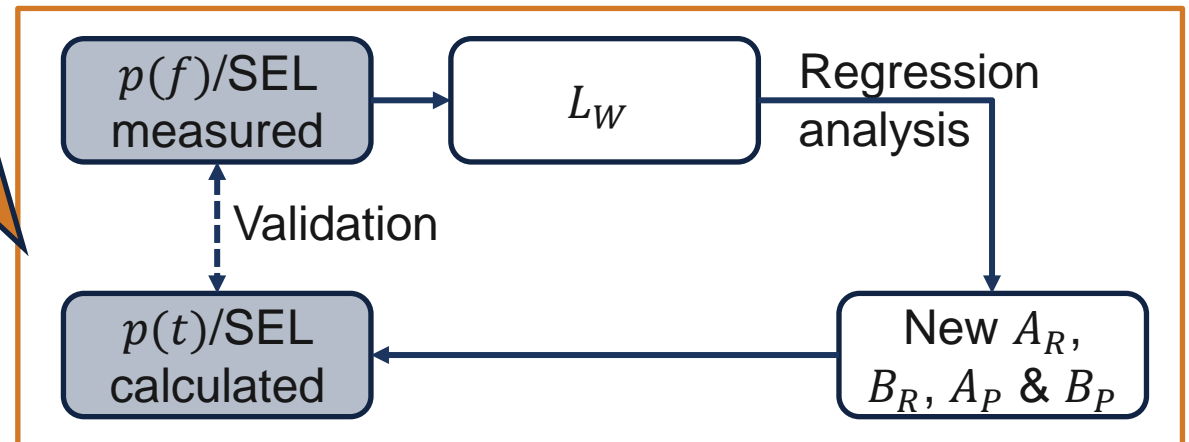

Possibilities for integrating sound emission changes

New coefficients from type approval data

SPB in IMAGINE based on ISO 11819-1

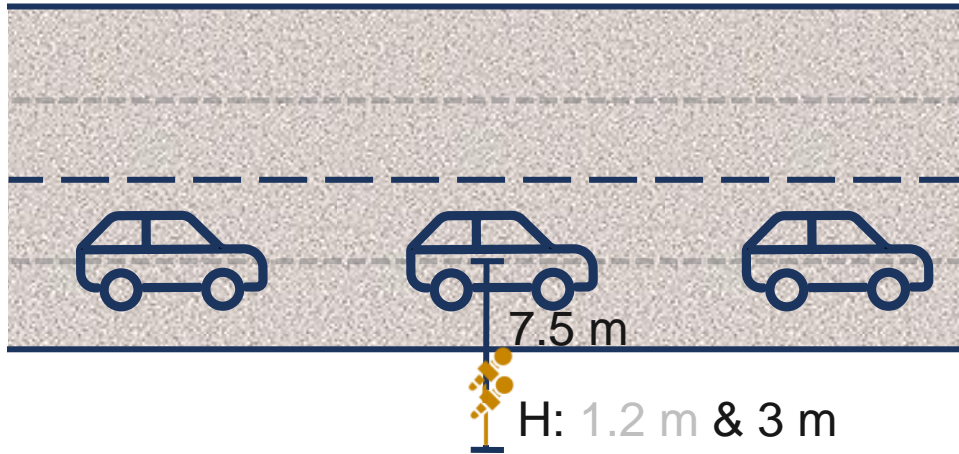

R51.03

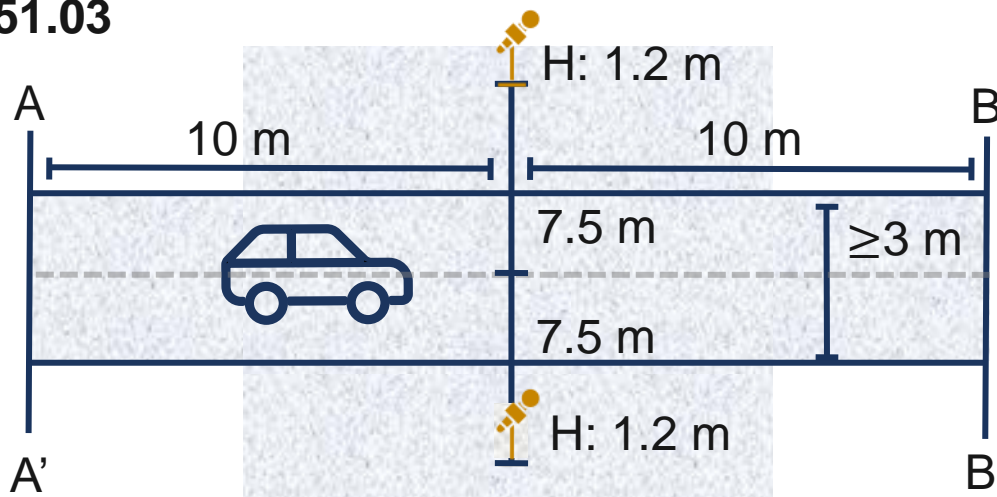

Procedure for new coefficients

Background:

- » Technical progress and changes in legislation are not considered in the coefficients
 - » Current coefficients are derived among other things from SPB measurements
- » Currently, no procedure for deriving new CNOSSOS-EU coefficients exists
 - » Conducting new SPB measurements is not resource-efficient and the issue remains for the future
- » Information about the technical progress and changes in legislation are available from type approval measurements

Possibilities for integrating sound emission changes

New coefficients from type approval data

SPB in IMAGINE based on ISO 11819-1

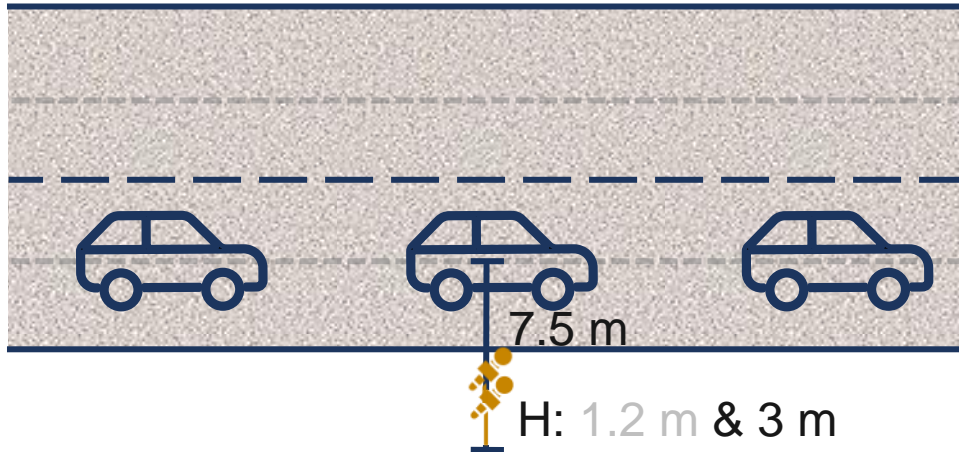

Advantage of SPB-based procedure for derivation of sound power coefficients:

- » Measurements of **real traffic/driving conditions**

R51.03

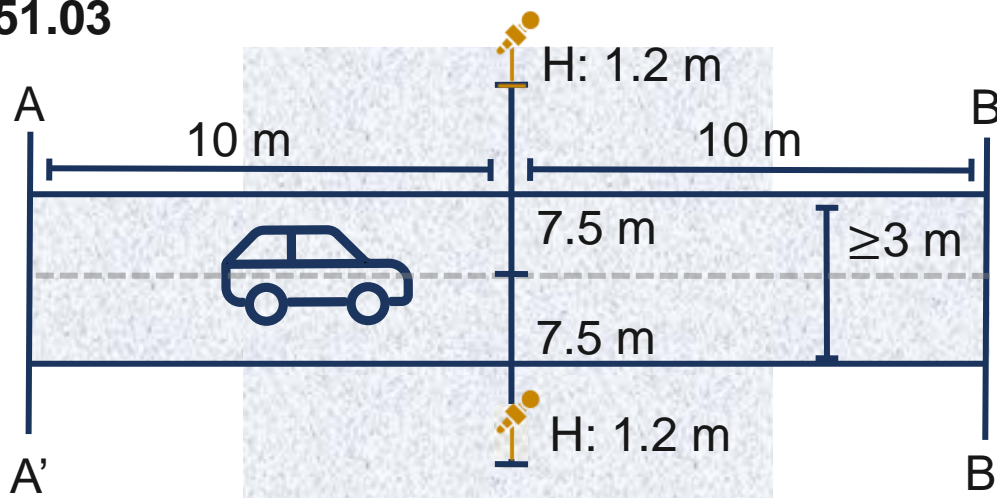

Advantage of TA-based procedure for derivation of sound power coefficients:

- » **Availability of TA data** without additional measurements
- » **Easy updating** of coefficients for new vehicles
- » **No/minimal influence** from **track** selection
- » High **repeatability/reproducibility**

Possibilities for integrating sound emission changes

New coefficients from type approval data

SPB (ISO 11819-1)

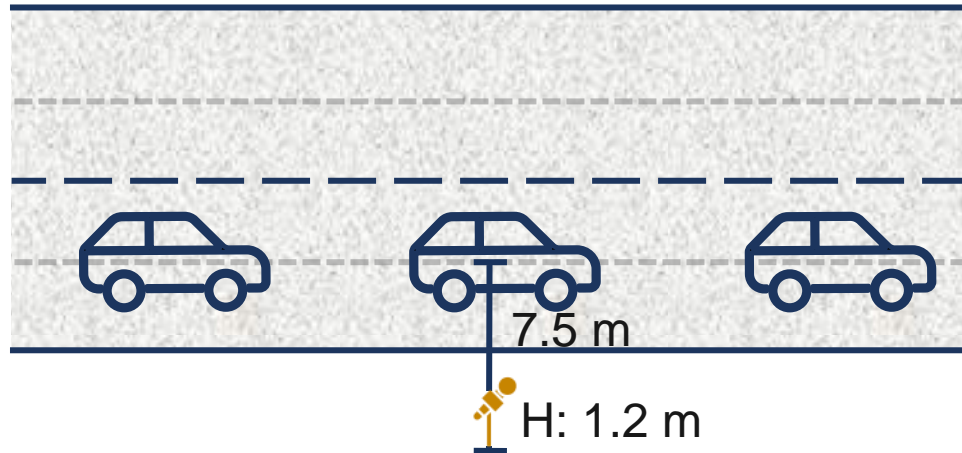

R51.03

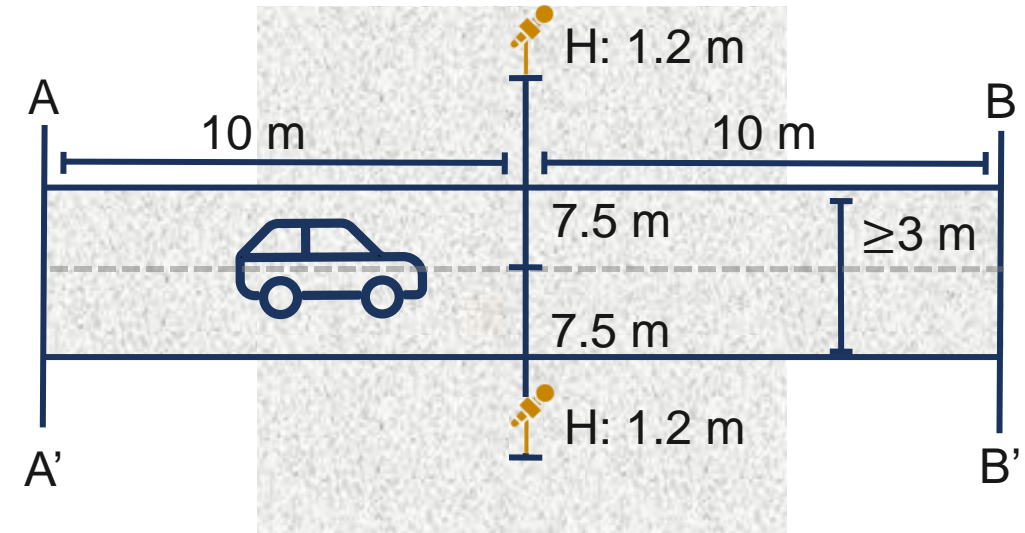

General information

- » Measurements usually on public roads
- » Measuring several vehicles passing by
- » Speed for the measurements depends on the vehicle and the type of road
- » Measurements on special test tracks
- » Measuring one vehicle at a time
- » Measurements are at **50 km/h** reference speed

Possibilities for integrating sound emission changes

New coefficients from type approval data

SPB (ISO 11819-1)

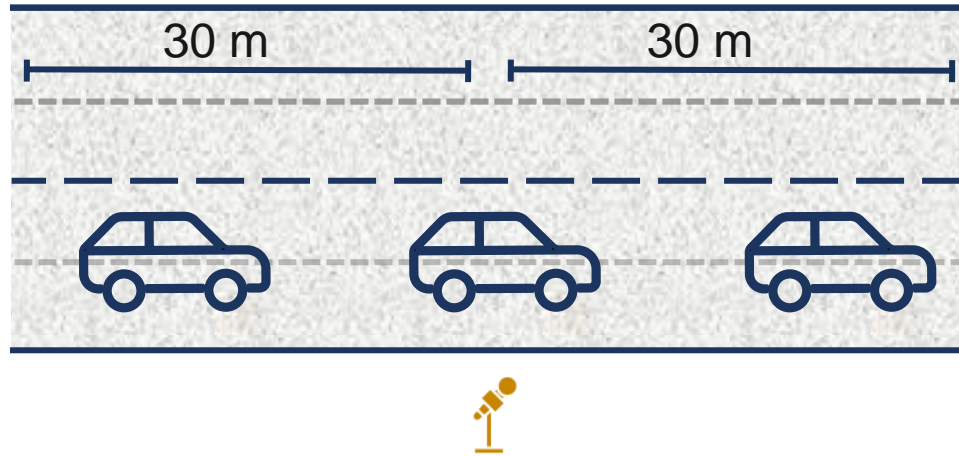

R51.03

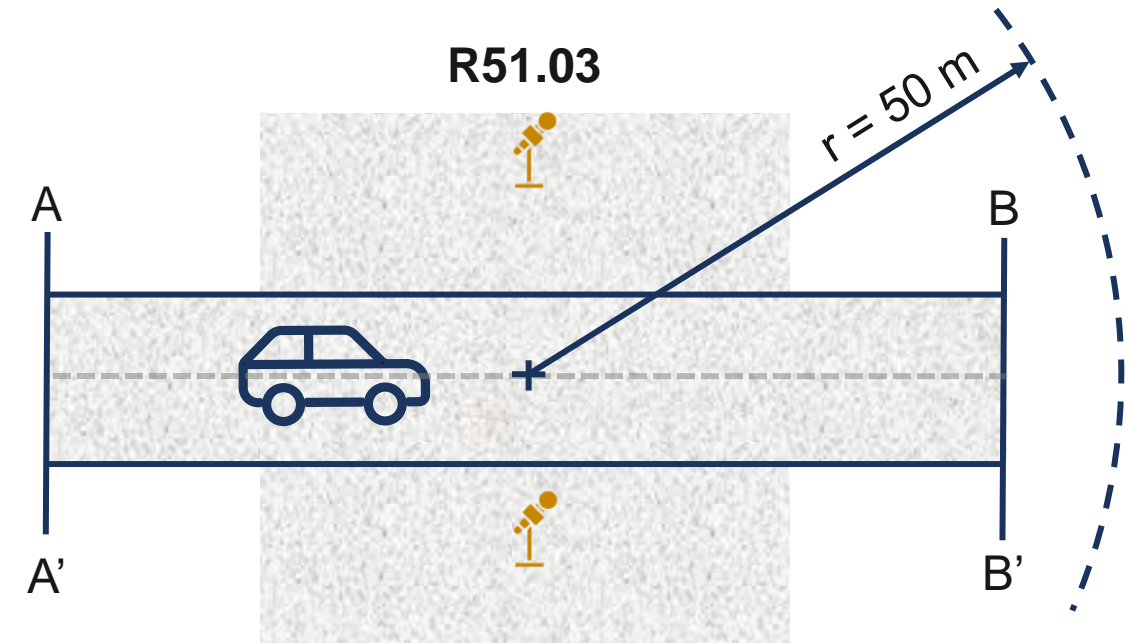

Road characteristics

- » Specified road section $\geq 30\text{m}$
 - » Road must be mainly flat and straight (light turns/ gradients $\leq 2\%$ negligible)
 - » Surface in good condition, but not new
- » Further requirements regarding free field conditions/no reflective objects
- » No reflecting obstacles within 50 m
- » Precisely defined road surface according to ISO 10844

Possibilities for integrating sound emission changes

New coefficients from type approval data

Speed

» Reference speeds **depending on type of road:**

- » **Low speed:** \emptyset 45 km/h - 64 km/h
- » **Medium speed:** \emptyset 65 km/h - 99 km/h
- » **High speed:** \emptyset > 100 km/h

» Vehicle speed to be measured approximately when the centre of the vehicle passes the microphone

» Reference speed is $50 \text{ km/h} \pm 1 \text{ km/h}$

» Vehicle speed measurement accuracy:

- » Continuously operating measurement devices:
 - » Accuracy at least $\pm 0,5 \text{ km/h}$
- » Independent measurement devices:
 - » Accuracy at least $\pm 0,2 \text{ km/h}$

Vehicle cat.	Road 1: Low speed [km/h]	Road 2: Medium speed [km/h]	Road 3: High speed [km/h]
Cars	50	80	110
Trucks	50	80	80

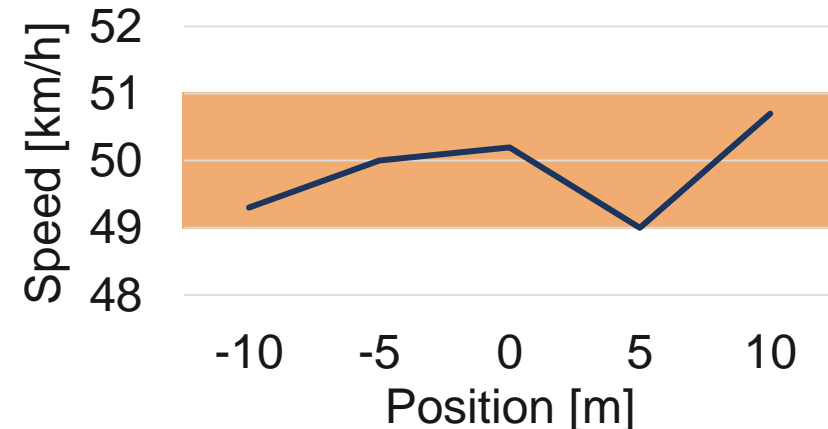

Possibilities for integrating sound emission changes

New coefficients from type approval data

SPB (ISO 11819-1)

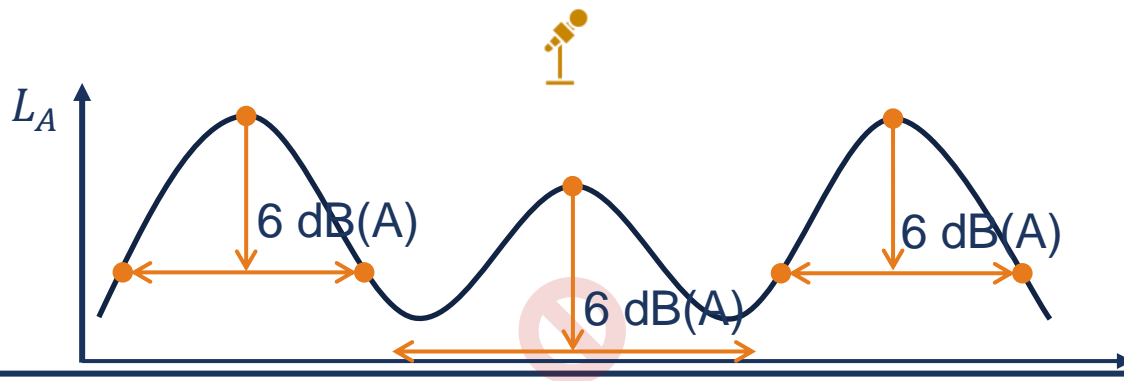
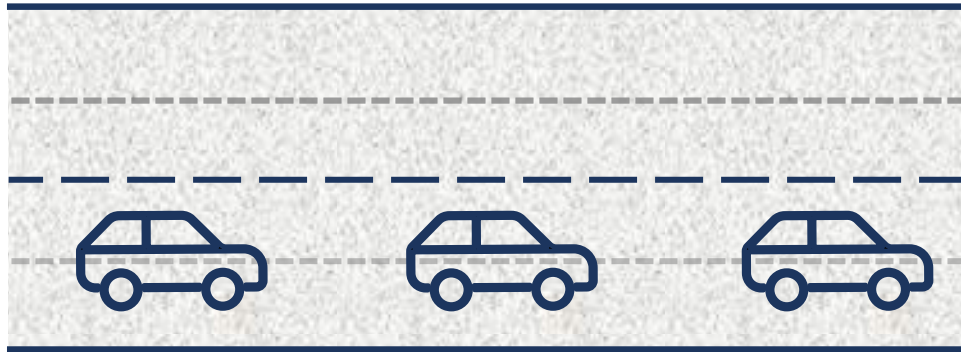

R51.03

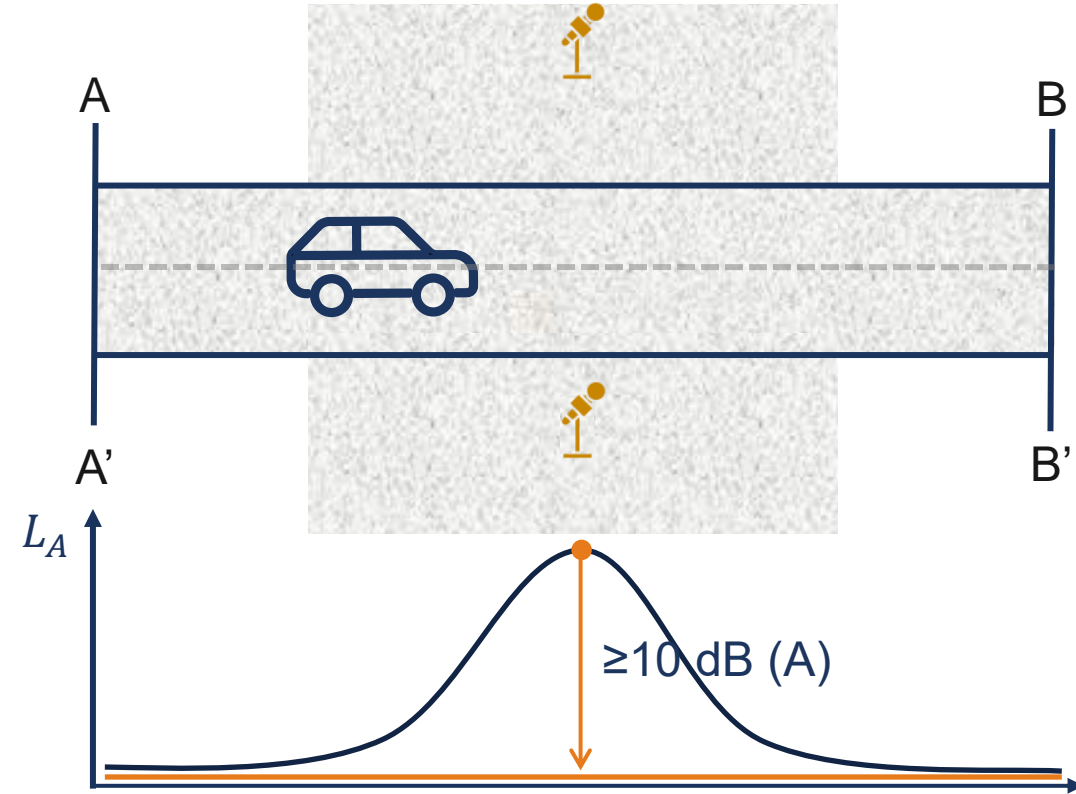

Background noise

- » At least 6 dB(A) before/after an event
- » No correction values required

- » At least 10 dB(A) difference
- » From 15 dB(A) no correction necessary

Possibilities for integrating sound emission changes

New coefficients from type approval data



SPB (ISO 11819-1)

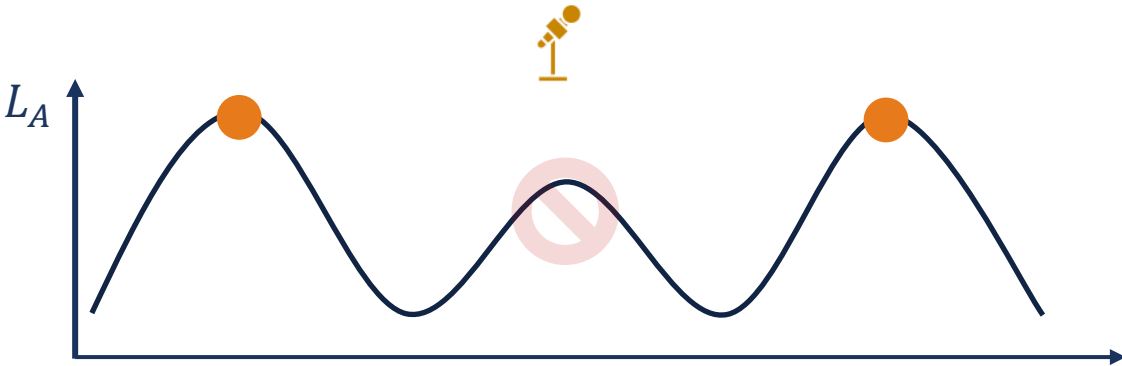
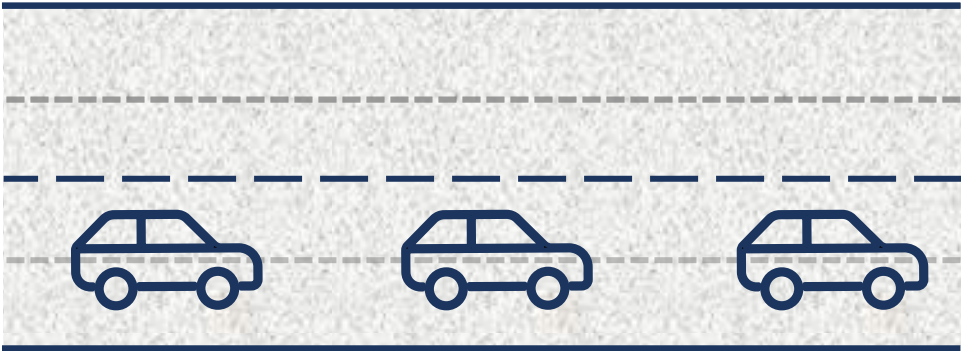

Determined parameter

» Maximum sound pressure level $L_{A,max}$

R51.03

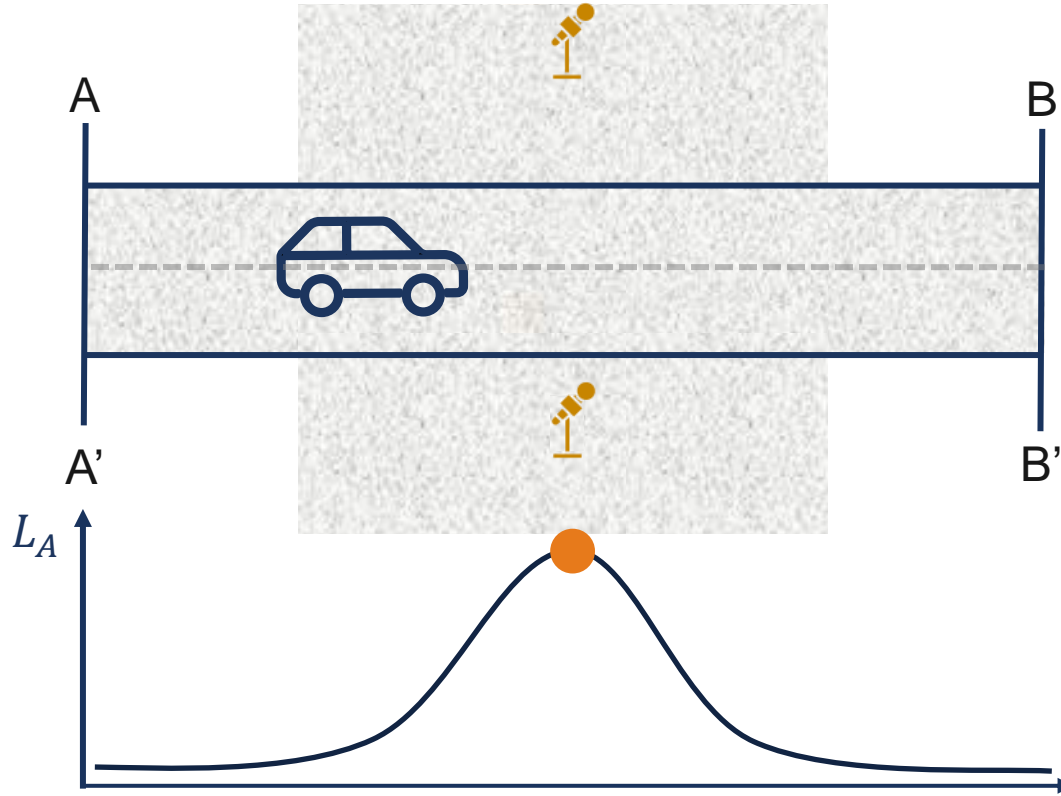









» Maximum sound pressure level $L_{A,max}$

Possibilities for integrating sound emission changes

New coefficients from type approval data

SPB (ISO 11819-1)

R51.03

		Limit	Measurement accuracy		Limit	Measurement accuracy
1	 [°C]	5 – 35 °C	± 1°C	1	 [°C]	5 – 40 °C ± 1°C
2	 [m/s]	≤ 5 m/s	--	2	 [m/s]	≤ 5 m/s ± 1 m/s
3	 [%]	--	--	3	 [%]	-- ± 5 %
4	 [hPa]	--	--	4	 [hPa]	-- ± 5 hPa

[1]: Temperature; [2]: Wind speed; [3]: Humidity; [4]: Air pressure

Environmental conditions

- » A correction to reference of 20°C to be applied
 - » Recommended: correct every measurement
 - » Correction according to ISO/TS 13471-2
- » No correction required

Possibilities for integrating sound emission changes

New coefficients from type approval data

SPB (ISO 11819-1)

R51.03

Preliminary/additional calculations

» No additional calculations

» Vehicle specific PMR $\rightarrow a_{urban}, a_{wot,ref}$

Measurements

Postprocessing

- » L_{SPB} from measurements of several vehicles
- » Temperature correction (ISO/TS 1347-2)
- » Statistical pass by index (SPBI) can be calculated

$$SPBI = 10 \log \left[W_P \times 10^{\frac{L_{SPB:P,v_{ref,P}}}{10}} + W_H \left(\frac{v_{ref,P}}{v_{ref,H}} \right) \times 10^{\frac{L_{SPB:H,v_{ref,H}}}{10}} \right]$$

- » Acceleration $a_{wot,i}$ (reached) \rightarrow Gear selection
- » Partial power factor k_p (& transmission factor k)
- » Maximum SPL for constant driving $L_{crs,rep}$ and for WOT driving $L_{wot,rep}$
- » Final sound pressure level for type approval

$$L_{urban} = L_{wot,rep} - k_p (L_{wot,rep} - L_{crs,rep})$$

Vehicle	Road 1		Road 2		Road 3	
	v_{ref} [km/h]	W	v_{ref} [km/h]	W	v_{ref} [km/h]	W
Cars (P)	50	0,9	80	0,8	110	0,7
Trucks (H)	50	0,1	80	0,2	80	0,3

* Note: For overview reasons it is referred to the respective standards regarding variable definition & abbreviations

Possibilities for integrating sound emission changes

New coefficients from type approval data

Procedures of using $L_{A,max}$ from type approvals

- » **Possibility 1:** The software used for type approval measurements already allows the determination of SEL or after small adjustments
- » **Possibility 2:** Derivation of conclusions about changes in SEL/ L_E based on changes in $L_{A,max}$
 - » Consideration: It is possible, if the noise characteristics do not change significantly (frequency content, directivity, ...)

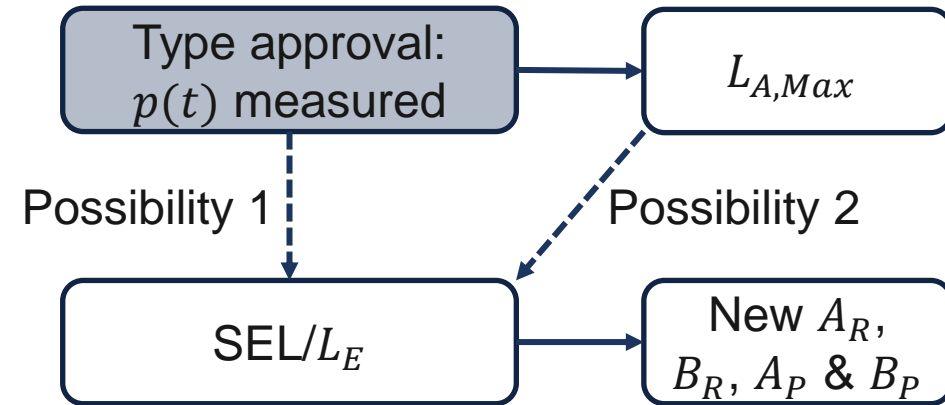

Pass-by noise measurements vehicle 1

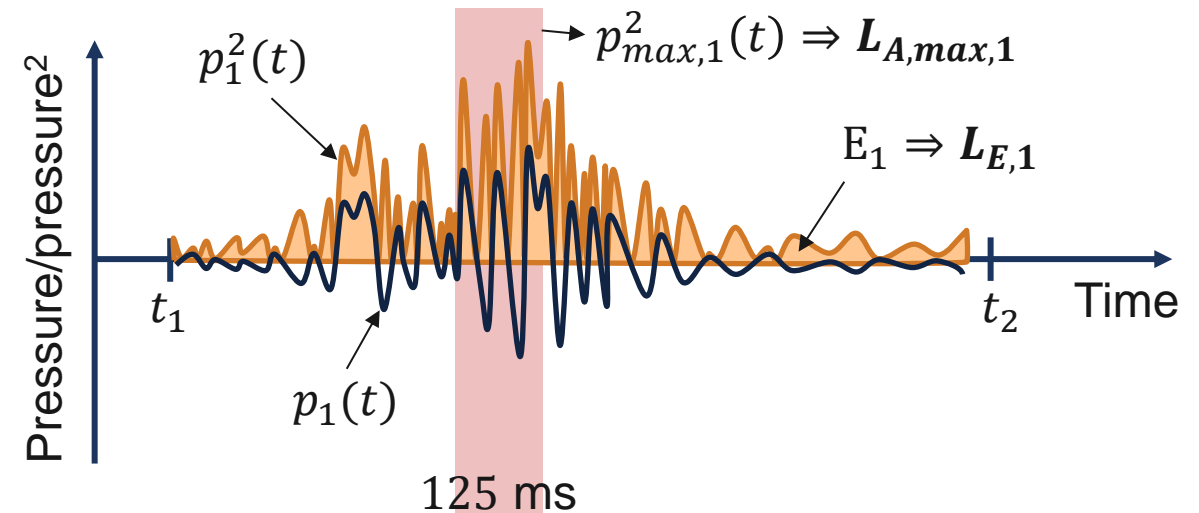

Possibilities for integrating sound emission changes

New coefficients from type approval data

Procedures of using $L_{A,max}$ from type approvals

- » **Possibility 1:** The software used for type approval measurements already allows the determination of SEL or after small adjustments
- » **Possibility 2:** Derivation of conclusions about changes in SEL/ L_E based on changes in $L_{A,max}$
 - » Consideration: It is possible, if the noise characteristics do not change significantly (frequency content, directivity, ...)

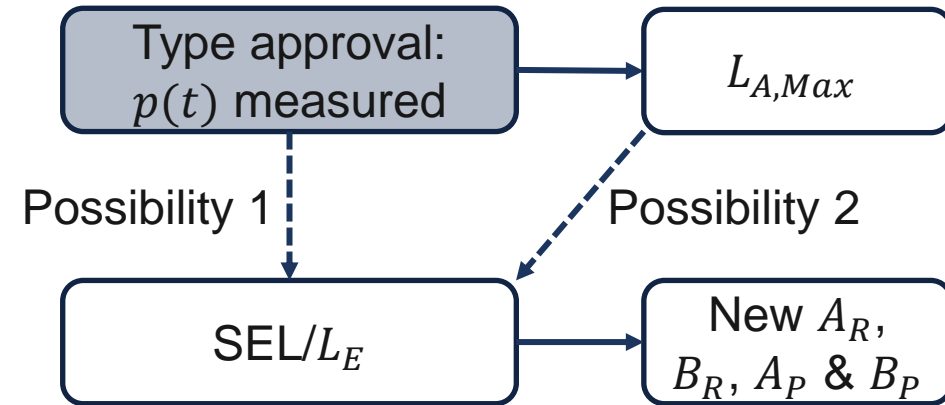

Pass-by noise measurements vehicle 2

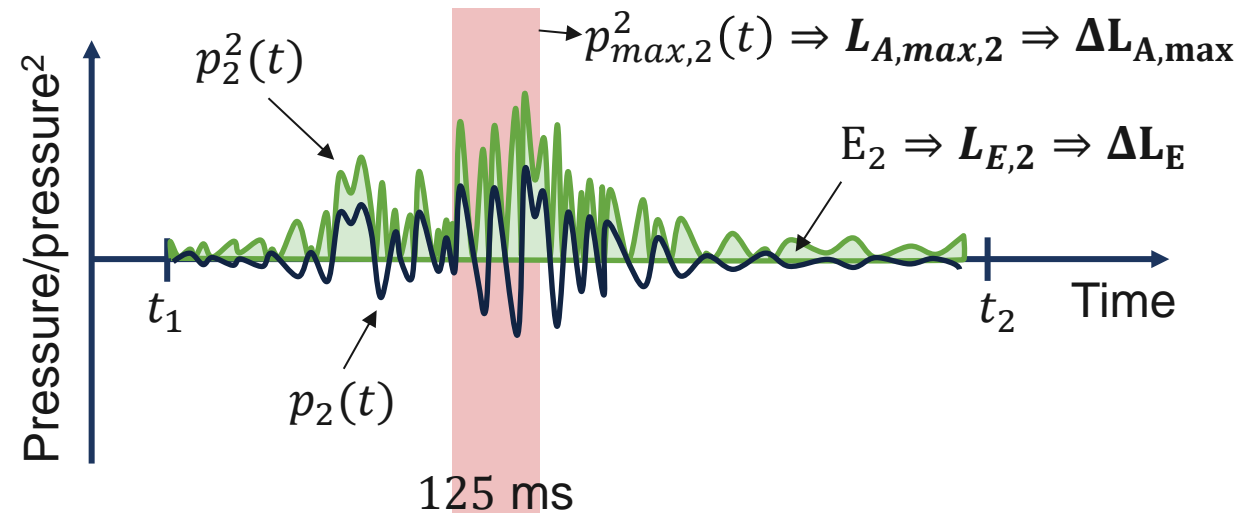

Possibilities for integrating sound emission changes

New coefficients from type approval data

Possibility 2 – Background information

Derivation of conclusions about changes in SEL/ L_E based on changes in $L_{A,max}$

- » SILVIA project started 2002 with the aim to establish a European Guidance Manual on the “Utilisation of Low-Noise Road Surfaces”
 - » The correlation (linear relation) between SEL/ L_E and $L_{A,max}$ ($-10 \cdot \log v$) has been investigated
 - » For cat. 1 > 88 %
 - » Based on [BEC01] measurements
- » [ASC22]: “ROSANNE project found good correlation between [pass-by noise levels] and SEL”

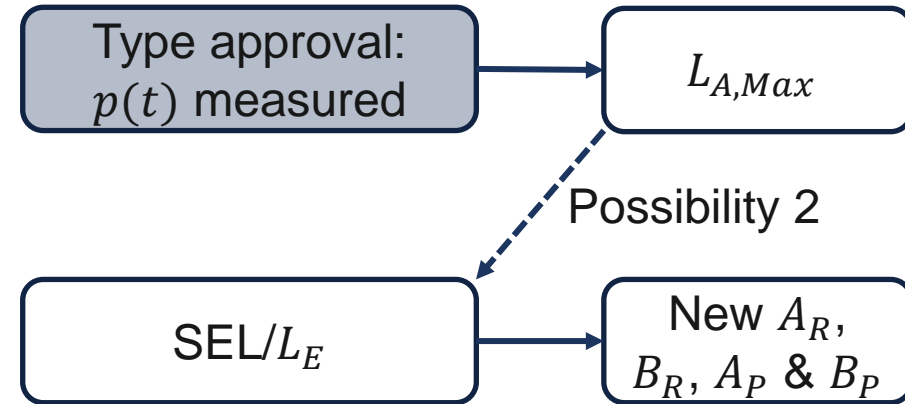

Correlation: SEL/ L_E and $L_{A,max} - 10 \cdot \log v$

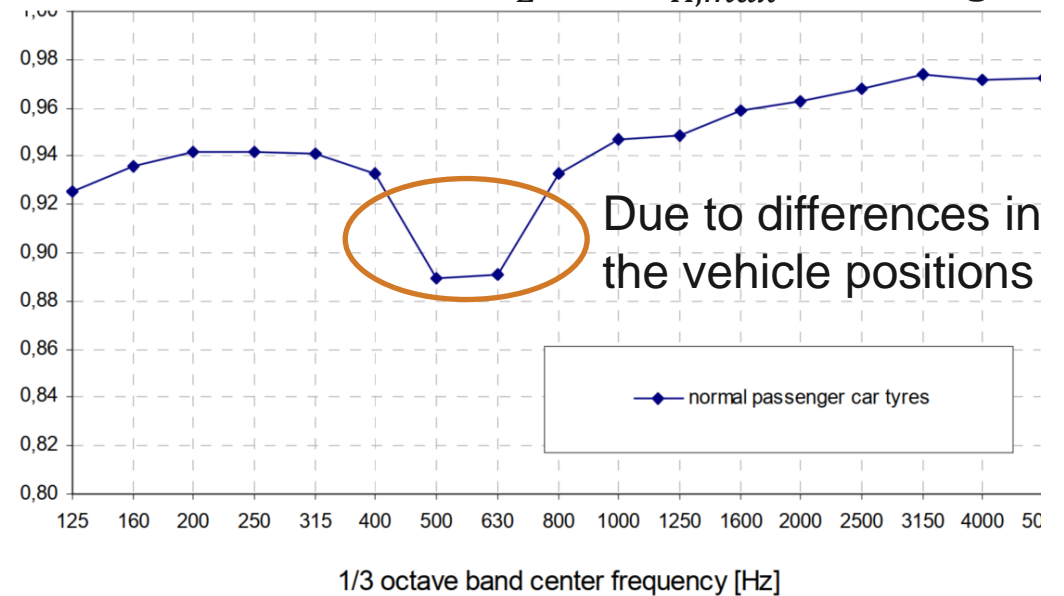

Motivation

- » Aim: Update CNOSSOS coefficients using type approval measurements (TA)
- » Procedure:
 1. Estimate calculation procedure to get SEL from TA
 2. Comprehend the CNOSSOS transfer functions (TFs) from point source (vehicle) to receiver (microphone)
 3. Rebuilding the TFs
 4. Identification of different conditions for TA compared to SPB reg. the TFs
 5. Adaption of the TFs (according to findings in 4.)
 6. Identification of different conditions for TA compared to SPB reg. the correction factors in CNOSSOS
 7. Estimation of coefficients for new vehicles

Transfer functions from L_W to SEL

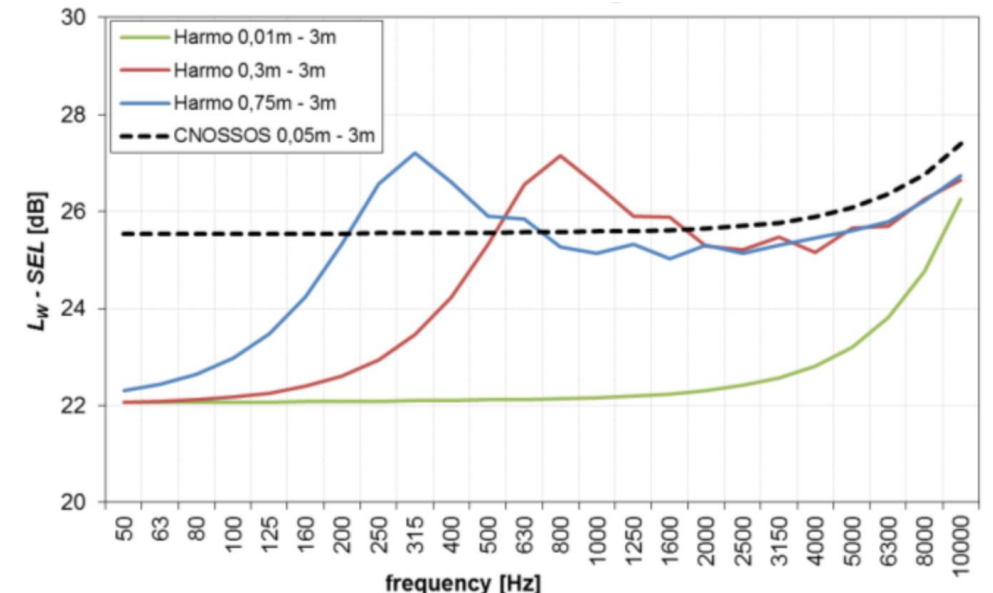

50 Hz	63 Hz	80 Hz	100 Hz	125 Hz	160 Hz	200 Hz	250 Hz	315 Hz	400 Hz	500 Hz	630 Hz
25.53	25.53	25.53	25.53	25.54	25.54	25.54	25.55	25.55	25.56	25.56	25.57
800 Hz	1 kHz	1.25 kHz	1.6 kHz	2 kHz	2.5 kHz	3.15 kHz	4 kHz	5 kHz	6.3 kHz	8 kHz	10 kHz
25.58	25.59	25.60	25.62	25.65	25.70	25.77	25.89	26.07	26.35	26.77	27.40

[BLO17] [PEE18]

Considered physical effects/ parameters

- » Geometric divergence
 - » Divergence Source height (5 cm)
 - » Microphone height (3 m)
 - » Microphone horizontal distance to line center (7.5 m)
 - $A_{div} = 20 \cdot \log(d) + 11$ [EUR15] [PEE18] [BLO17]
- » Integration angle (-80° → 80°) [PEE18]
- » Vehicle speed (70 km/h*) [EUR15] [PEE18] [BLO17]
- » Atmospheric absorption (15°C and 70% humidity) [EUR15]
 - » $A_{atm} = \alpha_{atm} \cdot d/1000$ with α_{atm} from ISO 9613-1
- » Ground reflection -3 dB [BLO17]

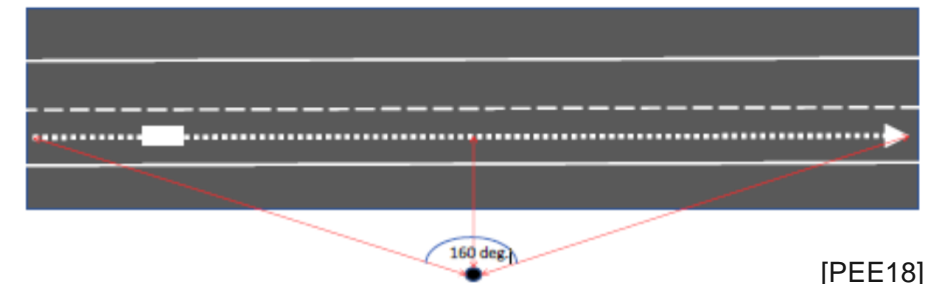
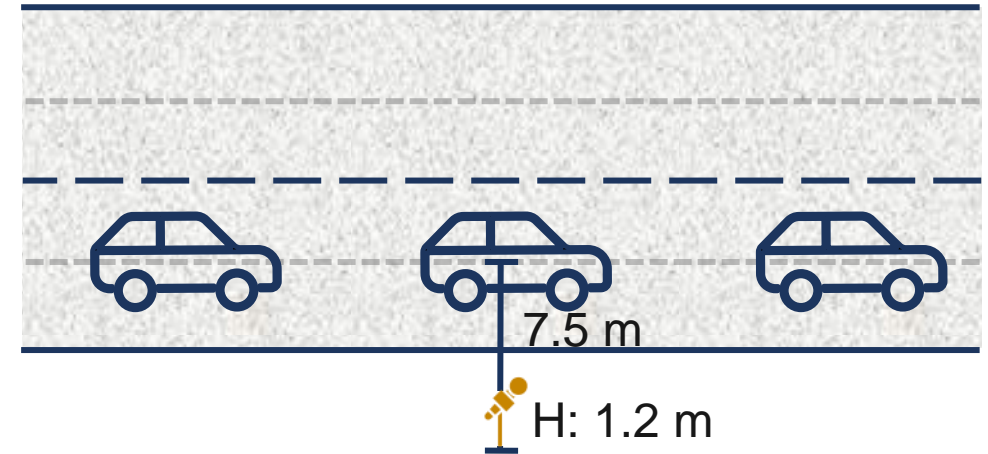

[PEE18]

* [BLO17]: Error in [EUR15] since TFs for cat. 2, 3 and 4 estimated for 50 km/h -> Error: $\log(70/50) = 1.46$ dB

Divergence

- » Issue: During pass-by, the distance between source and receiver changes
 - » There is no indication how this is taken into account in [PEE18] [BLO17]
- » In [WAT04], however, an approach is proposed:
 - » Authors:

G Watts^a, D van Maercke^b, H van Leeuwen^c, R Barelds^c, M Beuving^d, J Defrance^b,
 H Jonasson^e, R Nota^c, G Taraldsen^f and J Witte^c

Dynamic pass-by characteristic (influences on duration)

$$SEL = L_W - 10 \log v + 10 \log d + 10 \log \alpha - 10 \log [4\pi (d^2 + (h_r - h_s))] - \Delta L$$

Divergence

Reflection

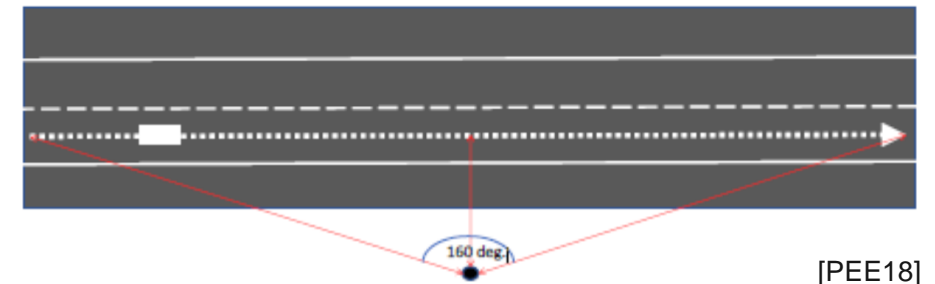
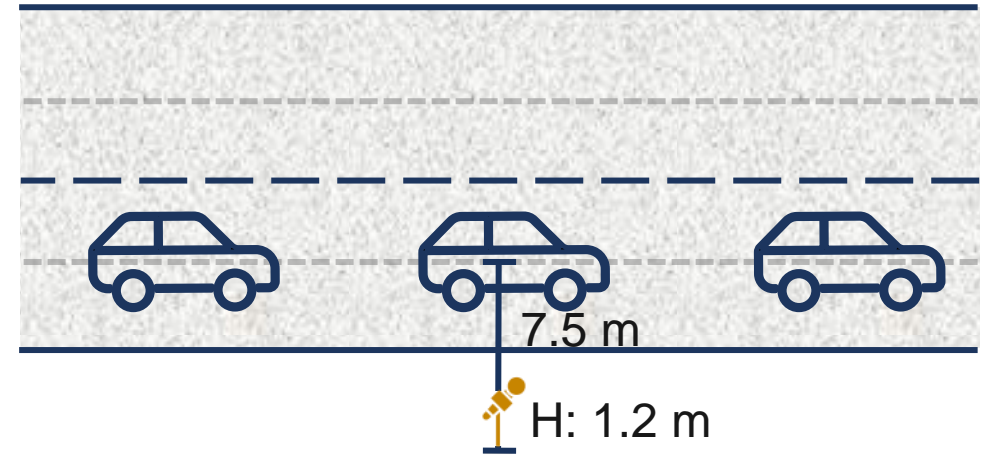

[PEE18]

Divergence

- » Issue: During pass-by, the distance between source and receiver changes
 - » There is no indication how this is taken into account in [PEE18] [BLO17]
- » In [WAT04], however, an approach is proposed:
 - » $SEL = L_W - 10 \log v + 10 \log d + 10 \log \alpha - 10 \log [4\pi(d^2 + (h_r - h_s))] - \Delta L$
 - » Faster passage reduces Time (& SEL)

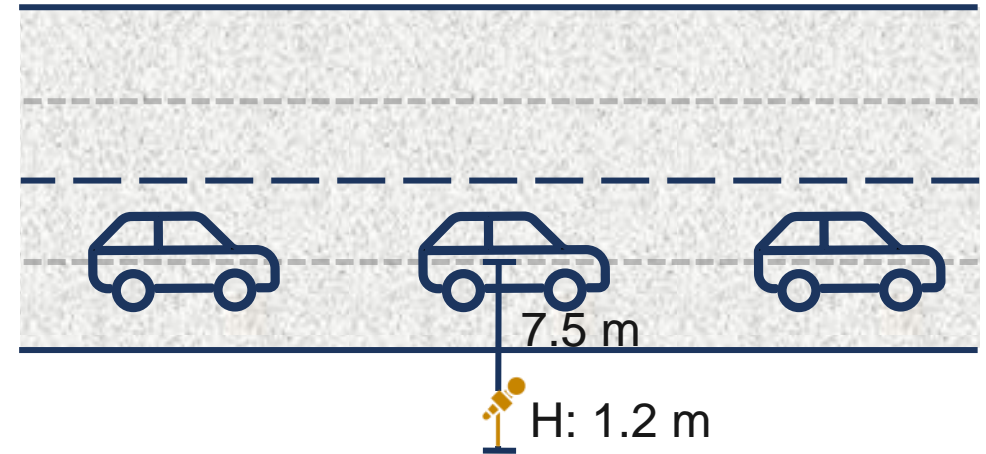
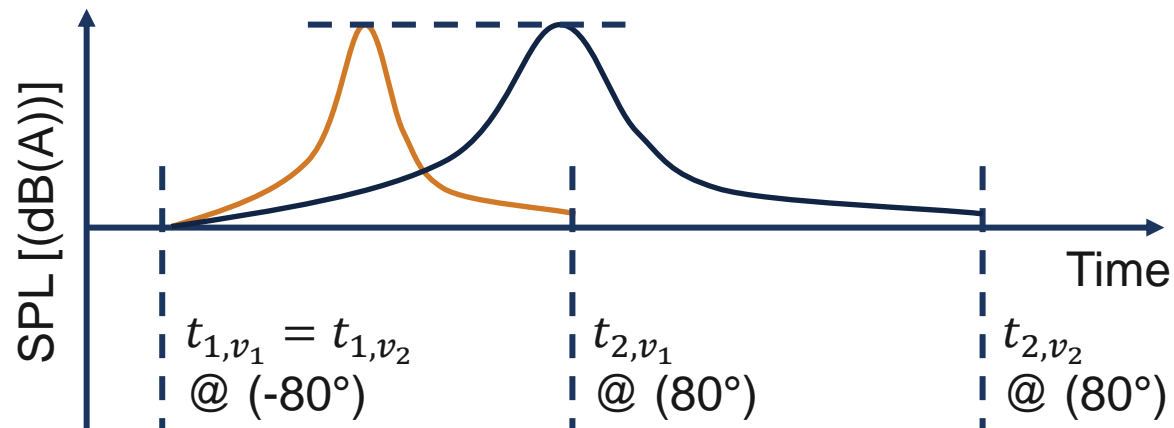

Divergence

- » Issue: During pass-by, the distance between source and receiver changes
 - » There is no indication how this is taken into account in [PEE18] [BLO17]
- » In [WAT04], however, an approach is proposed:
 - » $SEL = L_W - 10 \log v + 10 \log d + 10 \log \alpha - 10 \log [4\pi(d^2 + (h_r - h_s))] - \Delta L$
 - » Further horizontal distance from line increases considered track width (& SEL)

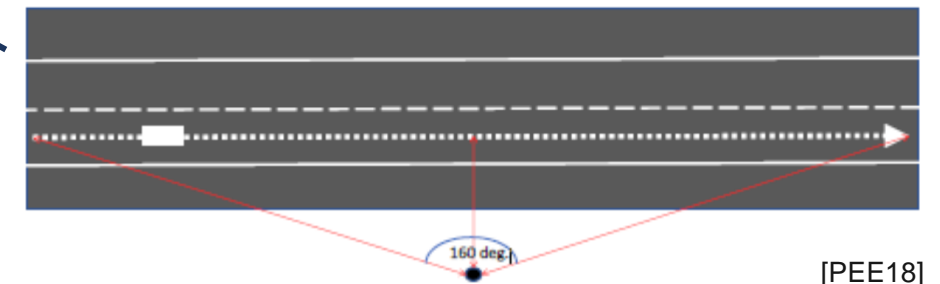
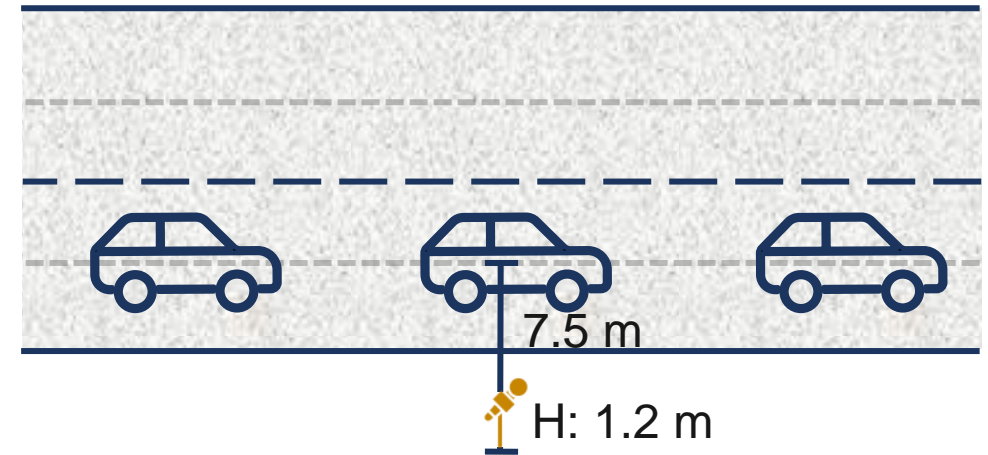
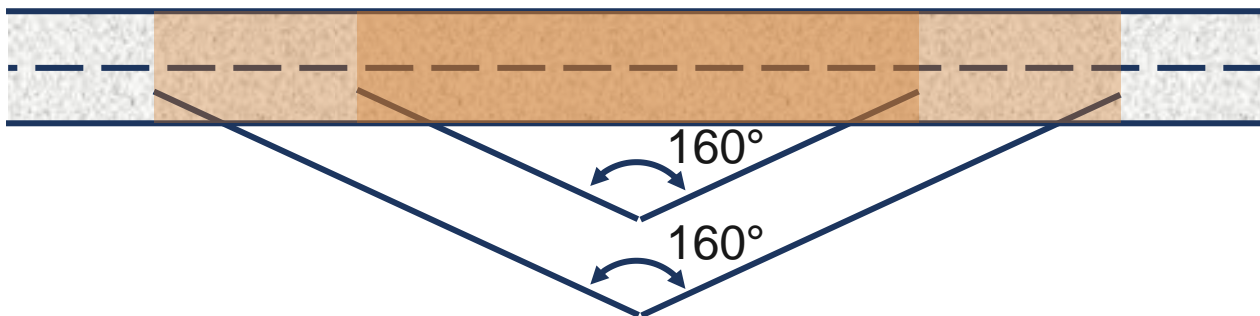

Divergence

- » Issue: During pass-by, the distance between source and receiver changes
 - » There is no indication how this is taken into account in [PEE18] [BLO17]
- » In [WAT04], however, an approach is proposed:
 - » $SEL = L_W - 10 \log v + 10 \log d + 10 \log \alpha - 10 \log [4\pi(d^2 + (h_r - h_s))] - \Delta L$
 - » In [WAT04] 180° (π), in [PEE18] 160° ; increasing angle increases considered track width (& SEL)

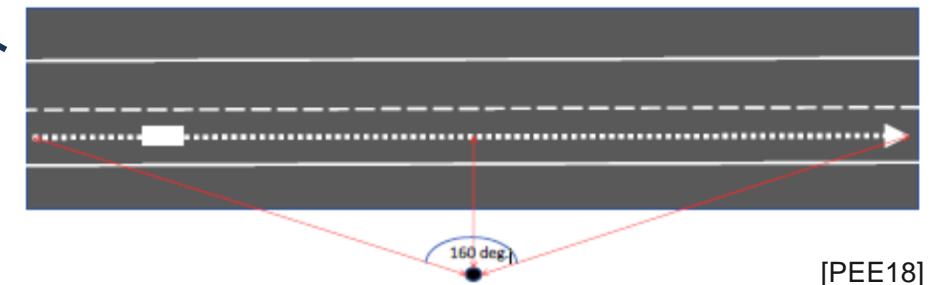
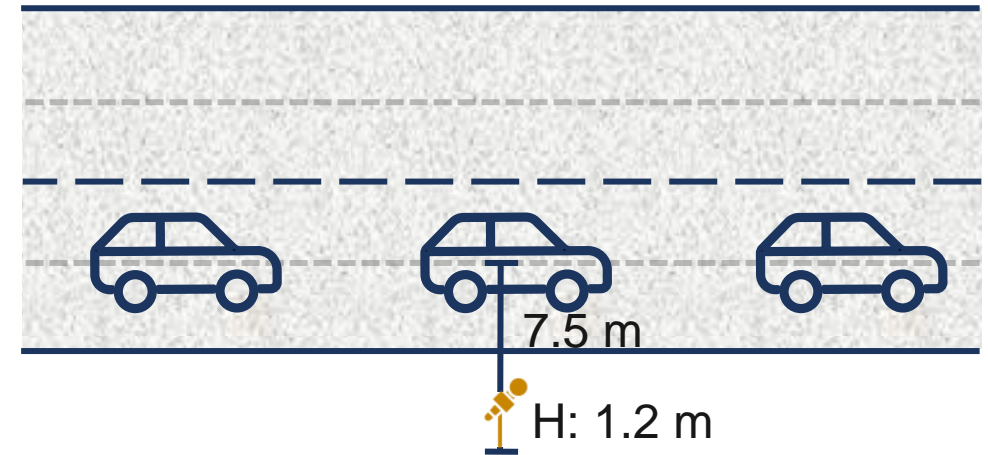
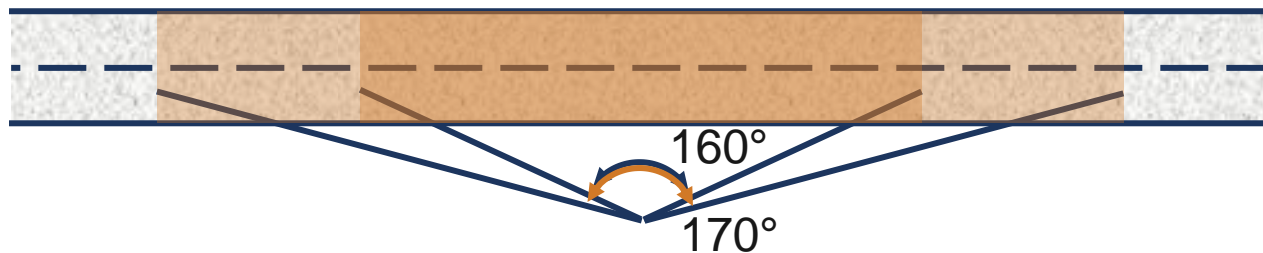

[PEE18]

Divergence

- » Issue: During pass-by, the distance between source and receiver changes
 - » There is no indication how this is taken into account in [PEE18] [BLO17]
- » In [WAT04], however, an approach is proposed:
 - » $SEL = L_W - 10 \log v + 10 \log d + 10 \log \alpha - 10 \log [4\pi(d^2 + (h_r - h_s))] - \Delta L$
 - » Conventional divergence for a 4π spherical point source
 - » [PEE18] “The text [...] should be neglected or corrected to represent a freefield (4π) point source, where the first reflection on the road surface is treated by the propagation model.”

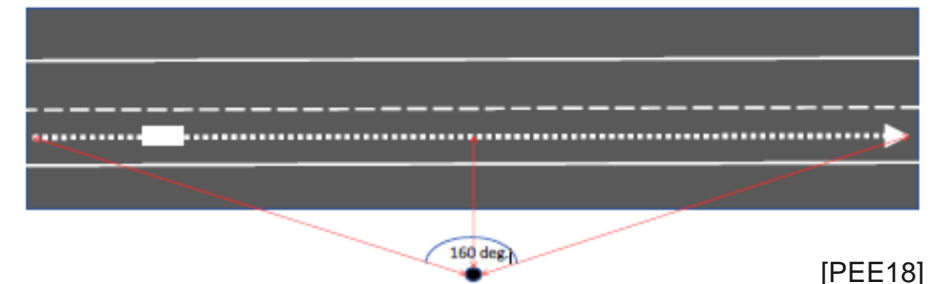
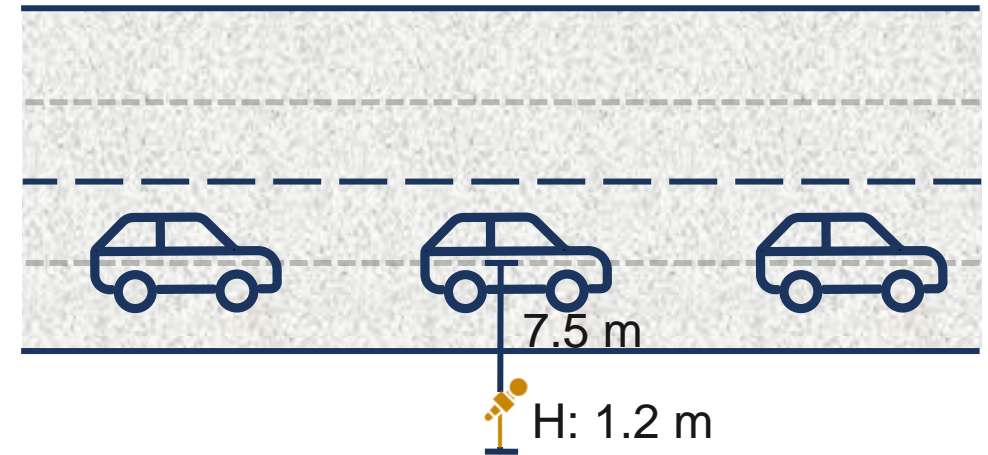

[PEE18]

Divergence

- » Issue: During pass-by, the distance between source and receiver changes
 - » There is no indication how this is taken into account in [PEE18] [BLO17]
- » In [WAT04], however, an approach is proposed:
 - » $SEL = L_W - 10 \log v + 10 \log d + 10 \log \alpha - 10 \log [4\pi(d^2 + (h_r - h_s))] - \Delta L$
 - » Conventional divergence for a 4π spherical point source
 - » [EUR15]“In this method, each vehicle [...] is represented by one single point source radiating uniformly into the $2\text{-}\pi$ half space above the ground. The first reflection on the road surface is treated implicitly.”

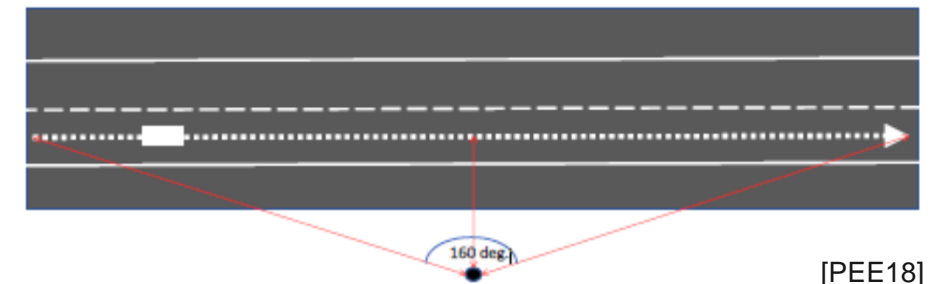
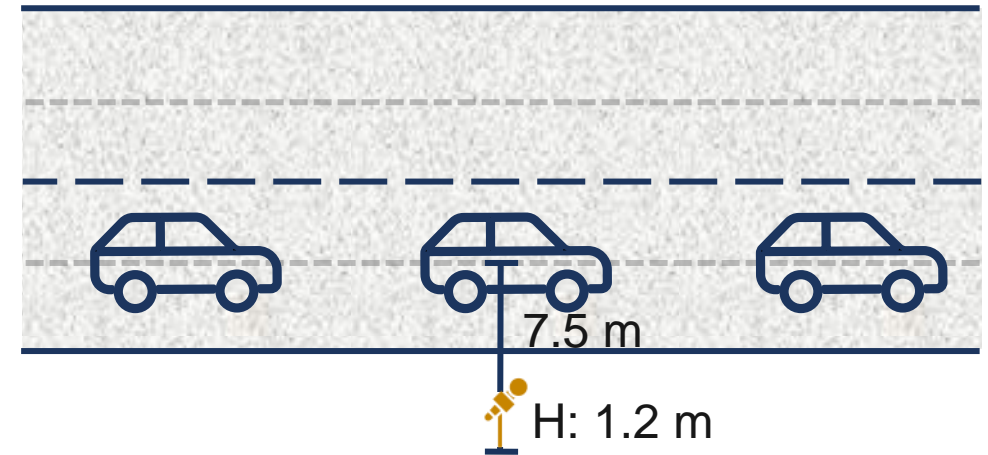

[PEE18]

Possibilities for integrating sound emission changes

New coefficients from TA data – Procedure – Step 2

Divergence

- » Issue: During pass-by, the distance between source and receiver changes
 - » There is no indication how this is taken into account in [PEE18] [BLO17]
- » In [WAT04], however, an approach is proposed:
 - » $SEL = L_W - 10 \log v + 10 \log d + 10 \log \alpha - 10 \log [4\pi(d^2 + (h_r - h_s))] - \Delta L$

Side note: This description is kept, but it may have to be from SEL to L_W

table I CNOSSOS transfer functions from L_W to SEL at 70 km/h, including atmospheric absorption and ground reflection ($A_{ground} = -3$ dB); source at 5 cm height and receiver at 7,5 m distance, 3 m height

50 Hz	63 Hz	80 Hz	100 Hz	125 Hz	160 Hz	200 Hz	250 Hz	315 Hz	400 Hz	500 Hz	630 Hz
25,53	25,53	25,53	25,53	25,54	25,54	25,54	25,55	25,55	25,56	25,56	25,57
800 Hz	1 kHz	1,25 kHz	1,6 kHz	2 kHz	2,5 kHz	3,15 kHz	4 kHz	5 kHz	6,3 kHz	8 kHz	10 kHz
25,58	25,59	25,60	25,62	25,65	25,70	25,77	25,89	26,07	26,35	26,77	27,40

[BLO17]

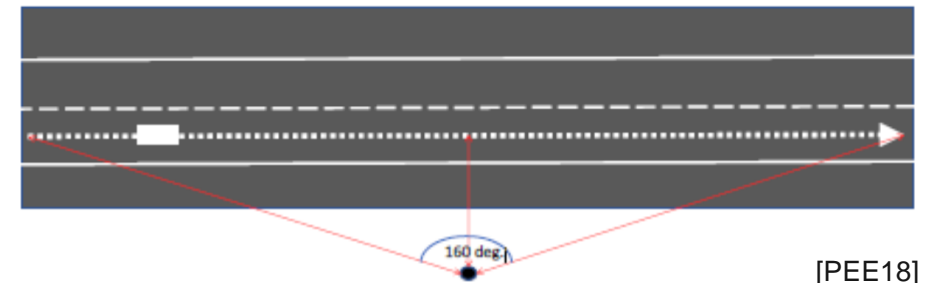
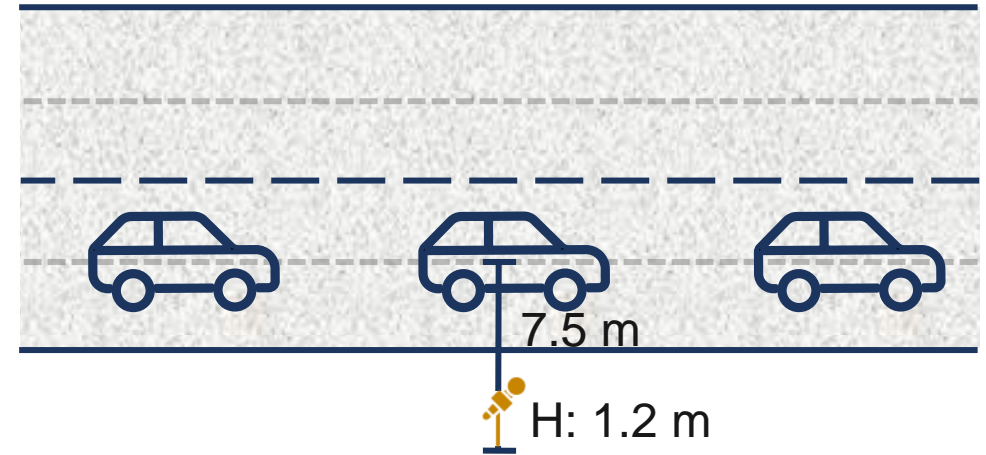

[PEE18]

Motivation

- » Aim: Update CNOSSOS coefficients using type approval measurements (TA)
- » Procedure:
 1. Estimate calculation procedure to get SEL from TA
 2. Comprehend the CNOSSOS transfer functions (TFs) from point source (vehicle) to receiver (microphone)
 3. Rebuilding the TFs
 4. Identification of different conditions for TA compared to SPB reg. the TFs
 5. Adaption of the TFs (according to findings in 4.)
 6. Identification of different conditions for TA compared to SPB reg. the correction factors in CNOSSOS
 7. Estimation of coefficients for new vehicles

Transfer functions from L_W to SEL

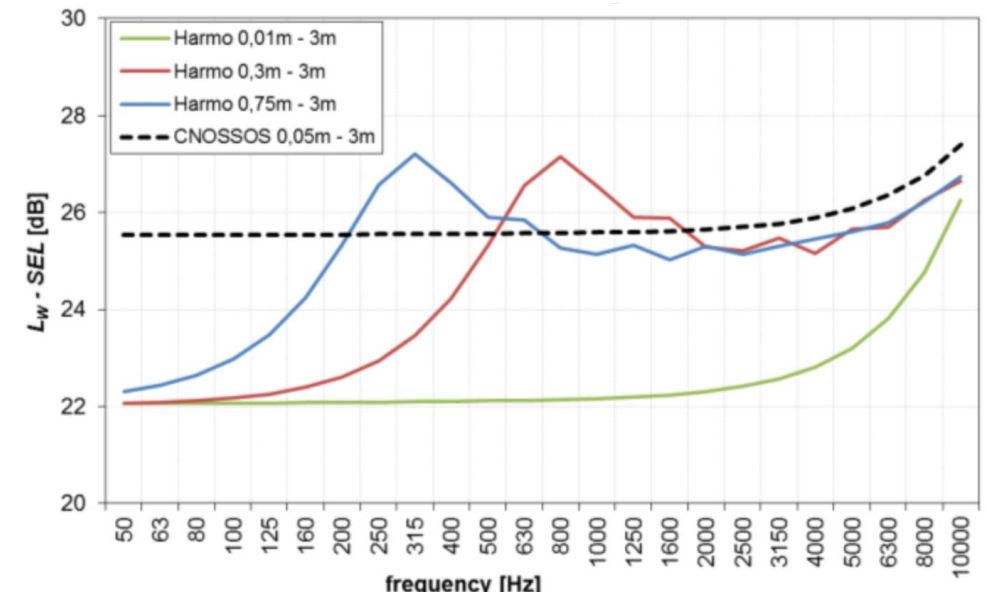

50 Hz	63 Hz	80 Hz	100 Hz	125 Hz	160 Hz	200 Hz	250 Hz	315 Hz	400 Hz	500 Hz	630 Hz
25.53	25.53	25.53	25.53	25.54	25.54	25.54	25.55	25.55	25.56	25.56	25.57
800 Hz	1 kHz	1.25 kHz	1.6 kHz	2 kHz	2.5 kHz	3.15 kHz	4 kHz	5 kHz	6.3 kHz	8 kHz	10 kHz
25.58	25.59	25.60	25.62	25.65	25.70	25.77	25.89	26.07	26.35	26.77	27.40

[BLO17] [PEE18]

Possibilities for integrating sound emission changes

New coefficients from TA data – Procedure – Step 3



Several issues arise

- » Definition issue:
 - » [PEE18]: “Transfer functions from LW to SEL”
 - » It should be the transfer function from SEL to LW
- » Final equation:

$$L_W = SEL + 10 \log\left(\frac{70}{3.6} \text{ m/s}\right) - 10 \log(7.5\text{m}) - 10 \log\left(\frac{160}{180} \pi + 10 \log[4\pi((7.5\text{m})^2 + (3\text{m} - 0.05\text{m})^2)] + \alpha_{atm} \cdot \frac{r_{atm}}{1000} - 3\text{dB}\right)$$

table I CNOSSOS transfer functions from L_W to SEL at 70 km/h, including atmospheric absorption and ground reflection ($A_{ground} = -3 \text{ dB}$); source at 5 cm height and receiver at 7,5 m distance, 3 m height

50 Hz	63 Hz	80 Hz	100 Hz	125 Hz	160 Hz	200 Hz	250 Hz	315 Hz	400 Hz	500 Hz	630 Hz
25,53	25,53	25,53	25,53	25,54	25,54	25,54	25,55	25,55	25,56	25,56	25,57
800 Hz	1 kHz	1,25 kHz	1,6 kHz	2 kHz	2,5 kHz	3,15 kHz	4 kHz	5 kHz	6,3 kHz	8 kHz	10 kHz
25,58	25,59	25,60	25,62	25,65	25,70	25,77	25,89	26,07	26,35	26,77	27,40

[BLO17]

$$A_{atm} = \alpha_{atm} \cdot d / 1000 \quad (2.5.13)$$

where

d is the direct 3D slant distance between the source and the receiver in m;

α_{atm} is the atmospheric attenuation coefficient in dB/km at the nominal centre frequency for each frequency band, in accordance with ISO 9613-1.

The values of the α_{atm} coefficient are given for a temperature of 15 °C, a relative humidity of 70 % and an atmospheric pressure of 101 325 Pa. They are calculated with the exact centre frequencies of the frequency band. These values comply with ISO 9613-1. Meteorological average over the long term shall be used if meteorological data is available.

[EUR15]

Preferred frequency, Hz	Relative humidity, %										
	10	15	20	30	40	50	60	70	80	90	100
50	2,68 × 10 ⁻¹	2,24 × 10 ⁻¹	1,89 × 10 ⁻¹	1,41 × 10 ⁻¹	1,11 × 10 ⁻¹	9,14 × 10 ⁻²	7,74 × 10 ⁻²	6,70 × 10 ⁻²	5,91 × 10 ⁻²	5,28 × 10 ⁻²	4,77 × 10 ⁻²
63	3,53 × 10 ⁻¹	3,10 × 10 ⁻¹	2,72 × 10 ⁻¹	2,12 × 10 ⁻¹	1,71 × 10 ⁻¹	1,42 × 10 ⁻¹	1,21 × 10 ⁻¹	1,05 × 10 ⁻¹	9,27 × 10 ⁻²	8,31 × 10 ⁻²	7,52 × 10 ⁻²
80	4,54 × 10 ⁻¹	4,13 × 10 ⁻¹	3,78 × 10 ⁻¹	3,11 × 10 ⁻¹	2,57 × 10 ⁻¹	2,17 × 10 ⁻¹	1,87 × 10 ⁻¹	1,63 × 10 ⁻¹	1,45 × 10 ⁻¹	1,30 × 10 ⁻¹	1,18 × 10 ⁻¹
100	5,77 × 10 ⁻¹	5,31 × 10 ⁻¹	5,04 × 10 ⁻¹	4,41 × 10 ⁻¹	3,78 × 10 ⁻¹	3,26 × 10 ⁻¹	2,85 × 10 ⁻¹	2,51 × 10 ⁻¹	2,24 × 10 ⁻¹	2,02 × 10 ⁻¹	1,84 × 10 ⁻¹
125	7,35 × 10 ⁻¹	6,67 × 10 ⁻¹	6,47 × 10 ⁻¹	6,01 × 10 ⁻¹	5,39 × 10 ⁻¹	4,79 × 10 ⁻¹	4,26 × 10 ⁻¹	3,81 × 10 ⁻¹	3,43 × 10 ⁻¹	3,12 × 10 ⁻¹	2,85 × 10 ⁻¹
160	9,56 × 10 ⁻¹	8,28 × 10 ⁻¹	8,06 × 10 ⁻¹	7,86 × 10 ⁻¹	7,40 × 10 ⁻¹	6,81 × 10 ⁻¹	6,21 × 10 ⁻¹	5,65 × 10 ⁻¹	5,16 × 10 ⁻¹	4,73 × 10 ⁻¹	4,36 × 10 ⁻¹
200	1,28	1,04	9,91 × 10 ⁻¹	9,89 × 10 ⁻¹	9,73 × 10 ⁻¹	9,30 × 10 ⁻¹	8,74 × 10 ⁻¹	8,15 × 10 ⁻¹	7,57 × 10 ⁻¹	7,04 × 10 ⁻¹	6,55 × 10 ⁻¹
250	1,78	1,33	1,22	1,21	1,23	1,22	1,18	1,13	1,07	1,02	9,59 × 10 ⁻¹
315	2,55	1,77	1,54	1,47	1,50	1,53	1,51	1,47	1,41	1,41	1,36
400	3,74	2,44	2,00	1,79	1,81	1,87	1,91	1,92	1,91	1,89	1,85
500	5,58	3,49	2,70	2,23	2,18	2,24	2,31	2,36	2,40	2,41	2,41
630	8,36	5,11	3,80	2,89	2,68	2,69	2,75	2,84	2,91	2,97	3,01
800	1,25 × 10	7,63	5,50	3,89	3,41	3,29	3,31	3,38	3,48	3,57	3,65
1 000	1,84 × 10	1,15 × 10	8,17	5,45	4,51	4,16	4,06	4,08	4,15	4,25	4,35
1 250	2,65 × 10	1,74 × 10	1,23 × 10	7,90	6,22	5,49	5,17	5,05	5,05	5,11	5,20
1 600	3,69 × 10	2,60 × 10	1,86 × 10	1,17 × 10	8,90	7,55	6,86	6,51	6,35	6,30	6,32
2 000	4,93 × 10	3,83 × 10	2,82 × 10	1,77 × 10	1,31 × 10	1,08 × 10	9,50	8,75	8,31	8,07	7,95
2 500	6,25 × 10	5,48 × 10	4,22 × 10	2,69 × 10	1,97 × 10	1,59 × 10	1,36 × 10	1,22 × 10	1,14 × 10	1,08 × 10	1,04 × 10
3 150	7,55 × 10	7,57 × 10	6,21 × 10	4,10 × 10	2,99 × 10	2,38 × 10	2,01 × 10	1,77 × 10	1,61 × 10	1,50 × 10	1,43 × 10
4 000	8,73 × 10	9,99 × 10	8,89 × 10	6,20 × 10	4,57 × 10	3,62 × 10	3,03 × 10	2,64 × 10	2,37 × 10	2,17 × 10	2,03 × 10
5 000	9,74 × 10	1,26 × 10 ²	1,22 × 10 ²	9,24 × 10	6,97 × 10	5,54 × 10	4,62 × 10	3,99 × 10	3,55 × 10	3,22 × 10	2,98 × 10
6 300	1,06 × 10 ²	1,51 × 10 ²	1,61 × 10 ²	1,35 × 10 ²	1,05 × 10 ²	8,47 × 10	7,08 × 10	6,11 × 10	5,40 × 10	4,87 × 10	4,47 × 10
8 000	1,14 × 10 ²	1,74 × 10 ²	2,02 × 10 ²	1,90 × 10 ²	1,56 × 10 ²	1,29 × 10 ²	1,08 × 10 ²	9,37 × 10	8,28 × 10	7,46 × 10	6,81 × 10
10 000	1,23 × 10 ²	1,95 × 10 ²	2,42 × 10 ²	2,57 × 10 ²	2,26 × 10 ²	1,92 × 10 ²	1,65 × 10 ²	1,44 × 10 ²	1,27 × 10 ²	1,15 × 10 ²	1,05 × 10 ²

[ISO9613-1]

Several issues arise

- » Definition issue:
 - » [PEE18]: “Transfer functions from LW to SEL”
 - » It should be the transfer function from SEL to LW
- » Final equation:
 - » $L_W = SEL + 10 \log\left(\frac{70}{3.6} \text{ m/s}\right) - 10 \log(7.5\text{m}) - 10 \log\frac{160}{180} \pi + 10 \log\left[4\pi\left((7.5\text{m})^2 + (3\text{m} - 0.05\text{m})^2\right)\right] + \alpha_{atm} \cdot \frac{r_{atm}}{1000} - 3\text{dB}$
 - » $r_{atm} \geq \sqrt{d^2 + (h_r - h_s)^2} = 8.0593\text{m}$
 - » $r_{atm} \leq \sqrt{b^2 + (h_r - h_s)^2} = 43.2914\text{m}$
 - » with $b = \frac{d}{\cos\left(\frac{\alpha}{2}\right)} = 43.1908\text{m}$

Transfer functions from L_W to SEL

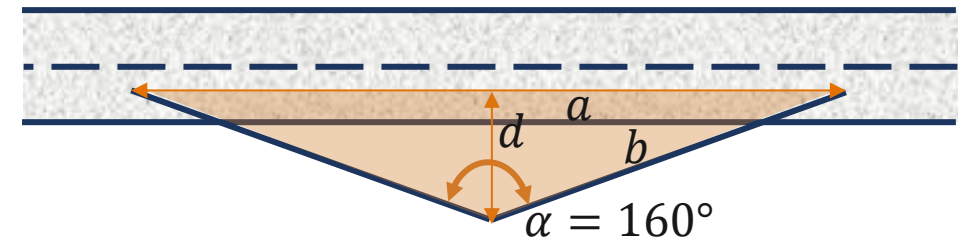
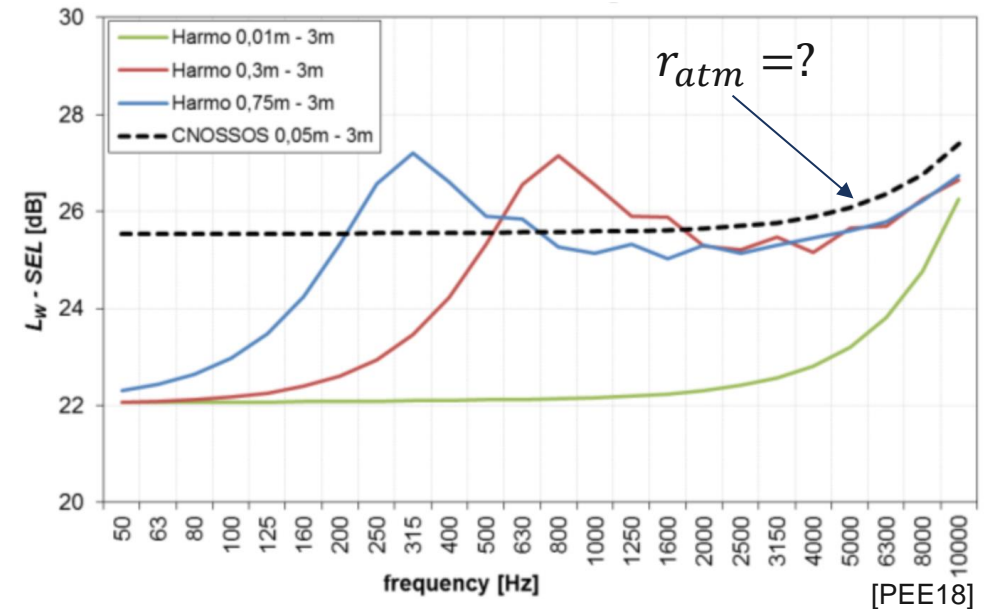

Several issues arise

- » Definition issue:
 - » [PEE18]: “Transfer functions from LW to SEL”
 - » It should be the transfer function from SEL to LW
- » Final equation:
 - » $L_W = SEL + 10 \log\left(\frac{70}{3.6} \text{ m/s}\right) - 10 \log(7.5\text{m}) - 10 \log\frac{160}{180} \pi + 10 \log[4\pi((7.5\text{m})^2 + (3\text{m} - 0.05\text{m})^2)] + \alpha_{atm} \cdot \frac{r_{atm}}{1000} - 3\text{dB}$
 - » $r_{atm} \geq \sqrt{d^2 + (h_r - h_s)^2} = 8.0593\text{m}$
 - » $r_{atm} \leq \sqrt{b^2 + (h_r - h_s)^2} = 43.2914\text{m}$
 - » $(r_{atm,min} + r_{atm,max})/2 = 25.68\text{m}$

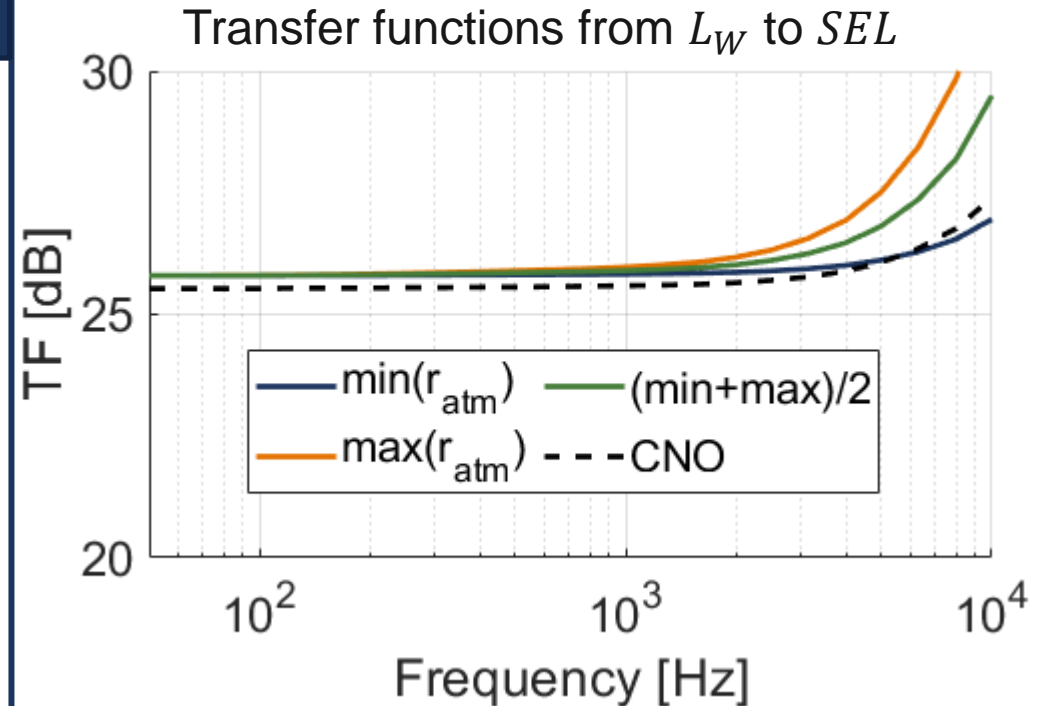

- An constant offset of 0.2681dB can be seen, probably due to rounding/smoothing
- Still a high deviation reg. frequency deviation

Calculation of exact r_{atm}

- » Definition issue:
 - » [PEE18]: “Transfer functions from LW to SEL”
 - » It should be the transfer function from SEL to LW
- » Final equation:
 - » $L_W = SEL + 10 \log\left(\frac{70}{3.6} \text{ m/s}\right) - 10 \log(7.5\text{m}) -$
 $10 \log\frac{160}{180} \pi + 10 \log[4\pi((7.5\text{m})^2 + (3\text{m} - 0.05\text{m})^2)] +$
 $\alpha_{atm} \cdot \frac{r_{atm}}{1000} - 3\text{dB}$
 - » $r_{atm} \geq \sqrt{d^2 + (h_r - h_s)^2} = 8.0593\text{m}$
 - » $r_{atm} \leq \sqrt{b^2 + (h_r - h_s)^2} = 43.2914\text{m}$
 - » $(r_{atm,min} + r_{atm,max})/2 = 25.68\text{m}$
 - » $r_{atm,ave} = 23.45\text{m}$

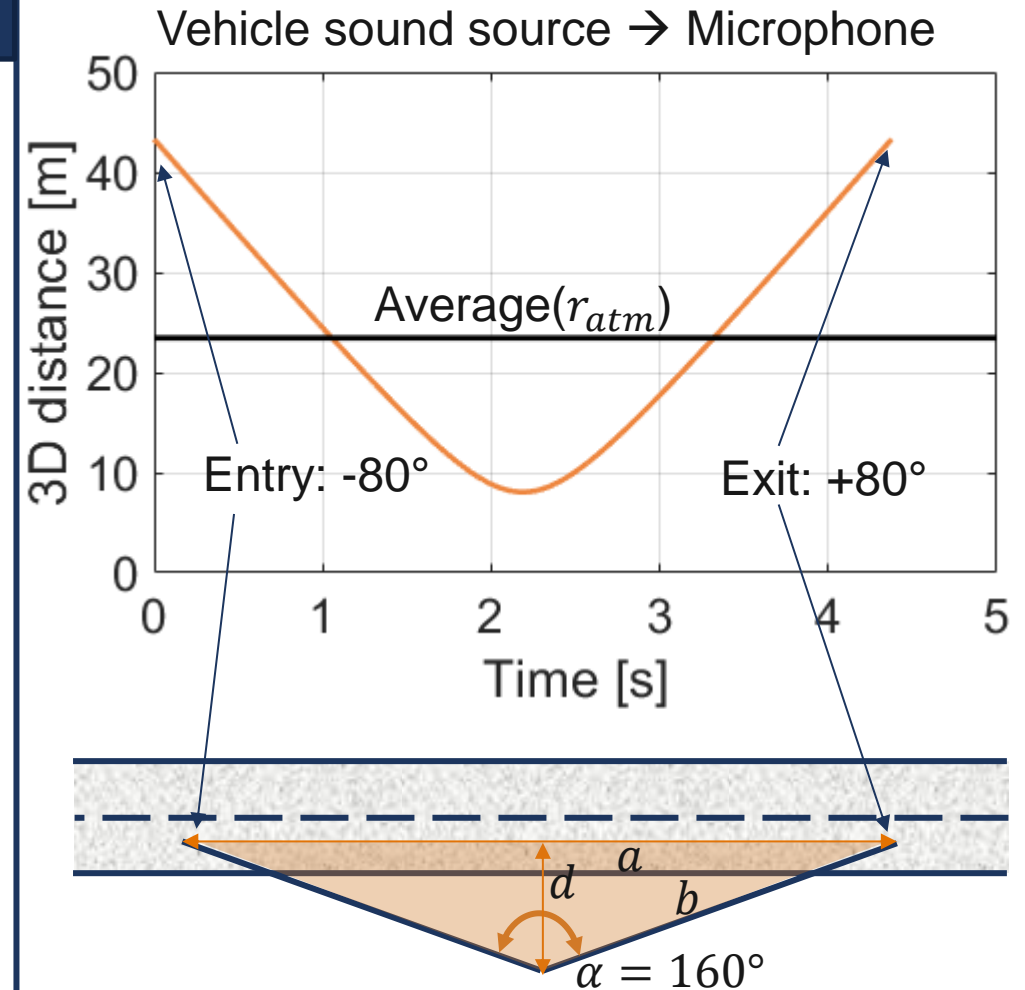

Calculation of exact r_{atm}

- » Definition issue:
 - » [PEE18]: “Transfer functions from LW to SEL”
 - » It should be the transfer function from SEL to LW
- » Final equation:
 - » $L_W = SEL + 10 \log\left(\frac{70}{3.6} \text{ m/s}\right) - 10 \log(7.5\text{m}) - 10 \log\left(\frac{160}{180} \pi + 10 \log\left[4\pi\left((7.5\text{m})^2 + (3\text{m} - 0.05\text{m})^2\right)\right] + \alpha_{atm} \cdot \frac{r_{atm}}{1000} - 3\text{dB}\right)$
 - » $r_{atm} \geq \sqrt{d^2 + (h_r - h_s)^2} = 8.0593\text{m}$
 - » $r_{atm} \leq \sqrt{b^2 + (h_r - h_s)^2} = 43.2914\text{m}$
 - » $(r_{atm,min} + r_{atm,max})/2 = 25.68\text{m}$
 - » $r_{atm,ave} = 23.45\text{m}$
 - » $r_{atm,best} = 13\text{m}$ (good regarding frequency dependency)

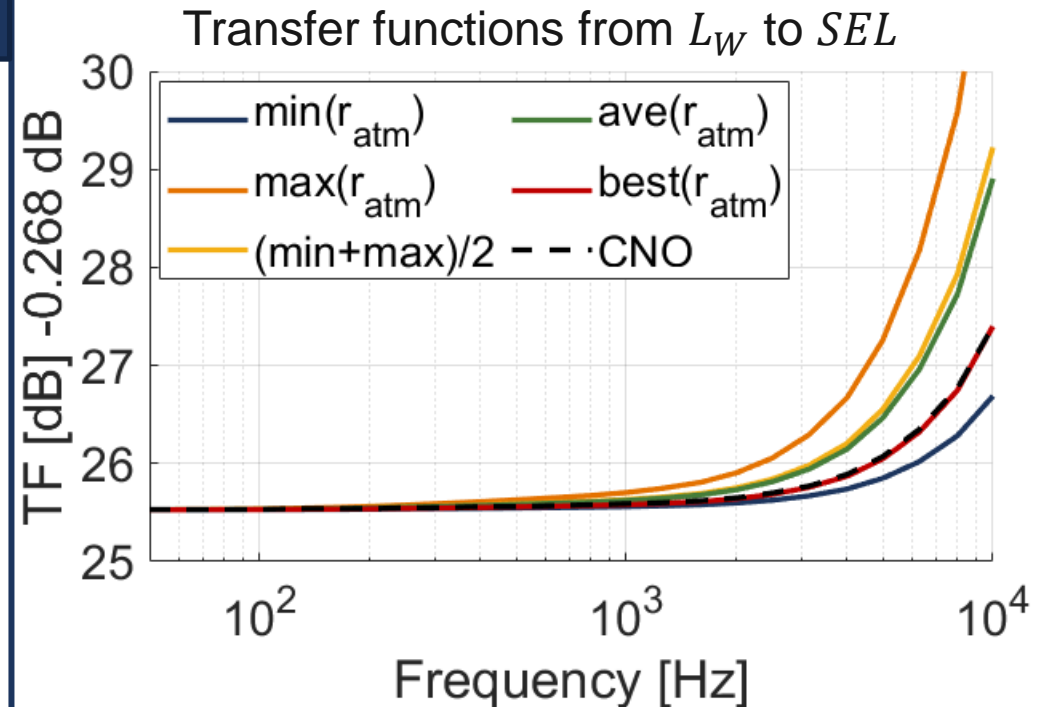

- » Offset of 0.2681dB subtracted for better comparibility

Calculation of exact SPL over the time (→SEL)

» New approach: Estimation based on a hypothetical source with 10^{-12} W for each frequency band

$$1. \quad L_p(t, f) = L_w - 11 - 20 \cdot \log(r_{atm}(t)) - \alpha_{atm}(f) \cdot \frac{r_{atm}(t)}{1000} + \Delta L$$

$$= 10 \cdot \log\left(\frac{P}{P_0}\right) = 0 \text{ dB}$$

Constant over time
and frequency

$$= 10 \cdot \log(4\pi) = 11 \text{ dB}$$

Constant parameter

Depending considered track
width, microphone position and
vehicle speed

Frequency and time
dependent atmospheric
absorption

Assumed to be 3dB
acc. to CNOSSOS

Calculation of exact SPL over the time (→SEL)

» New approach: Estimation based on a hypothetical source with 10^{-12} W for each frequency band

1.
$$L_p(t, f) = L_w - 11 - 20 \cdot \log(r_{atm}(t)) - \alpha_{atm}(f) \cdot \frac{r_{atm}(t)}{1000} + \Delta L$$

2. Relative sound pressure
$$\frac{p(t, f)}{p_0} = 10^{L_p(t, f) \cdot 0.1}$$

3.
$$SEL(f) = 10 \cdot \log\left(\text{sum}\left(\frac{p(t, f)}{p_0}\right)\right) + 10 \cdot \log(\Delta t)$$

4. For source power 10^{-12} W, the inverse SEL equals the transfer function

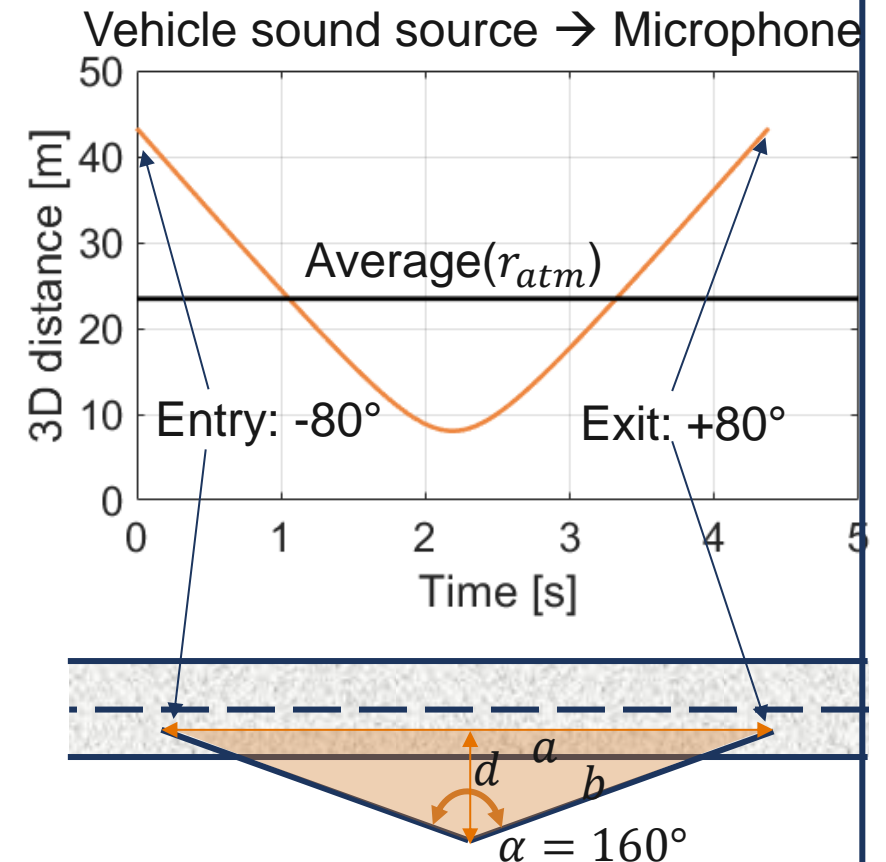

Calculation of exact SPL over the time (→SEL)

» New approach: Estimation based on a hypothetical source with 10^{-12} W for each frequency band

1.
$$L_p(t, f) = L_w - 11 - 20 \cdot \log(r_{atm}(t)) - \alpha_{atm}(f) \cdot \frac{r_{atm}(t)}{1000} + \Delta L$$

2. Relative sound pressure
$$\frac{p(t, f)}{p_0} = 10^{L_p(t, f) \cdot 0.1}$$

3.
$$SEL(f) = 10 \cdot \log\left(\text{sum}\left(\frac{p(t, f)}{p_0}\right)\right) + 10 \cdot \log(\Delta t)$$

4. For source power 10^{-12} W, the inverse SEL equals the transfer function

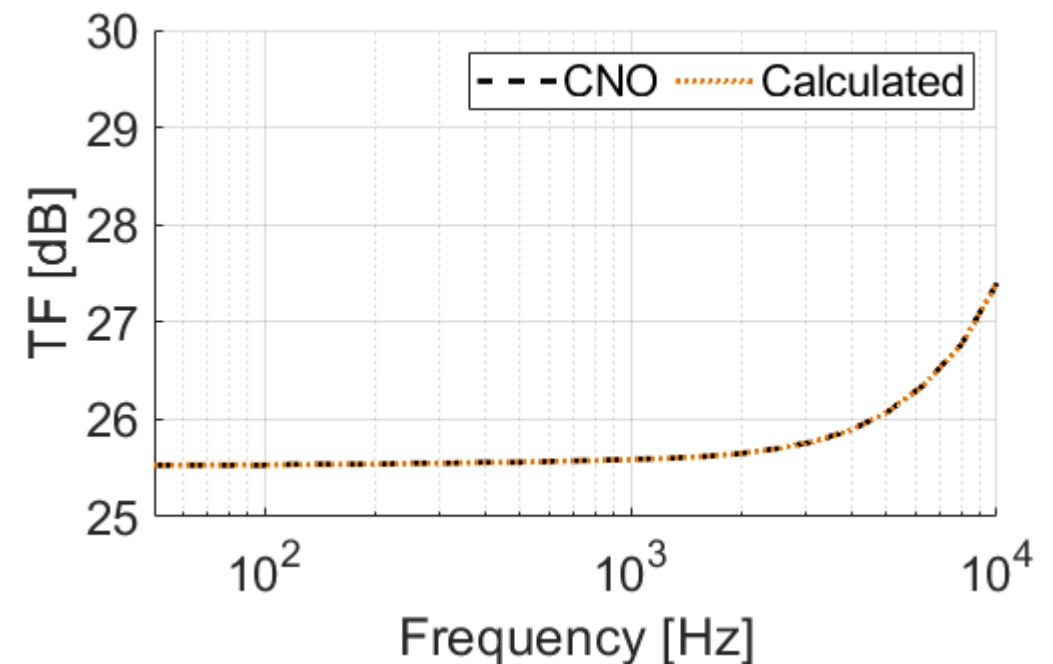

Motivation

- » Aim: Update CNOSSOS coefficients using type approval measurements (TA)
- » Procedure:
 1. Estimate calculation procedure to get SEL from TA
 2. Comprehend the CNOSSOS transfer functions (TFs) from point source (vehicle) to receiver (microphone)
 3. Rebuilding the TFs
 4. Identification of different conditions for TA compared to SPB reg. the TFs
 5. Adaption of the TFs (according to findings in 4.)
 6. Identification of different conditions for TA compared to SPB reg. the correction factors in CNOSSOS
 7. Estimation of coefficients for new vehicles

Transfer functions from L_W to SEL

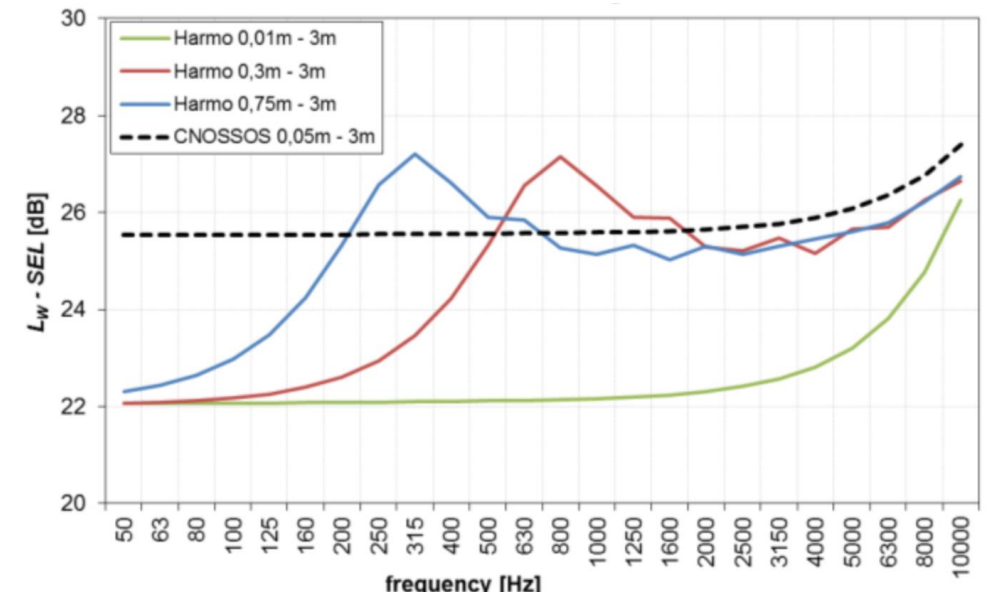

50 Hz	63 Hz	80 Hz	100 Hz	125 Hz	160 Hz	200 Hz	250 Hz	315 Hz	400 Hz	500 Hz	630 Hz
25.53	25.53	25.53	25.53	25.54	25.54	25.54	25.55	25.55	25.56	25.56	25.57
800 Hz	1 kHz	1.25 kHz	1.6 kHz	2 kHz	2.5 kHz	3.15 kHz	4 kHz	5 kHz	6.3 kHz	8 kHz	10 kHz
25.58	25.59	25.60	25.62	25.65	25.70	25.77	25.89	26.07	26.35	26.77	27.40

[BLO17] [PEE18]

Possibilities for integrating sound emission changes

New coefficients from TA data – Procedure – Step 4

Required changes

- » Microphone position
 - » 1.2 m height instead of 3 m
- » Reference vehicle speed
 - » 50 km/h instead of 70 km/h
- » Considered angle/track width
 - » Before +/-80°, for TA narrower
- » If required reference conditions (temperature, humidity)
 - » Currently $T = 15^{\circ}\text{C}$ & $h = 70\%$
- » New: vehicle acceleration for trajectory calculation

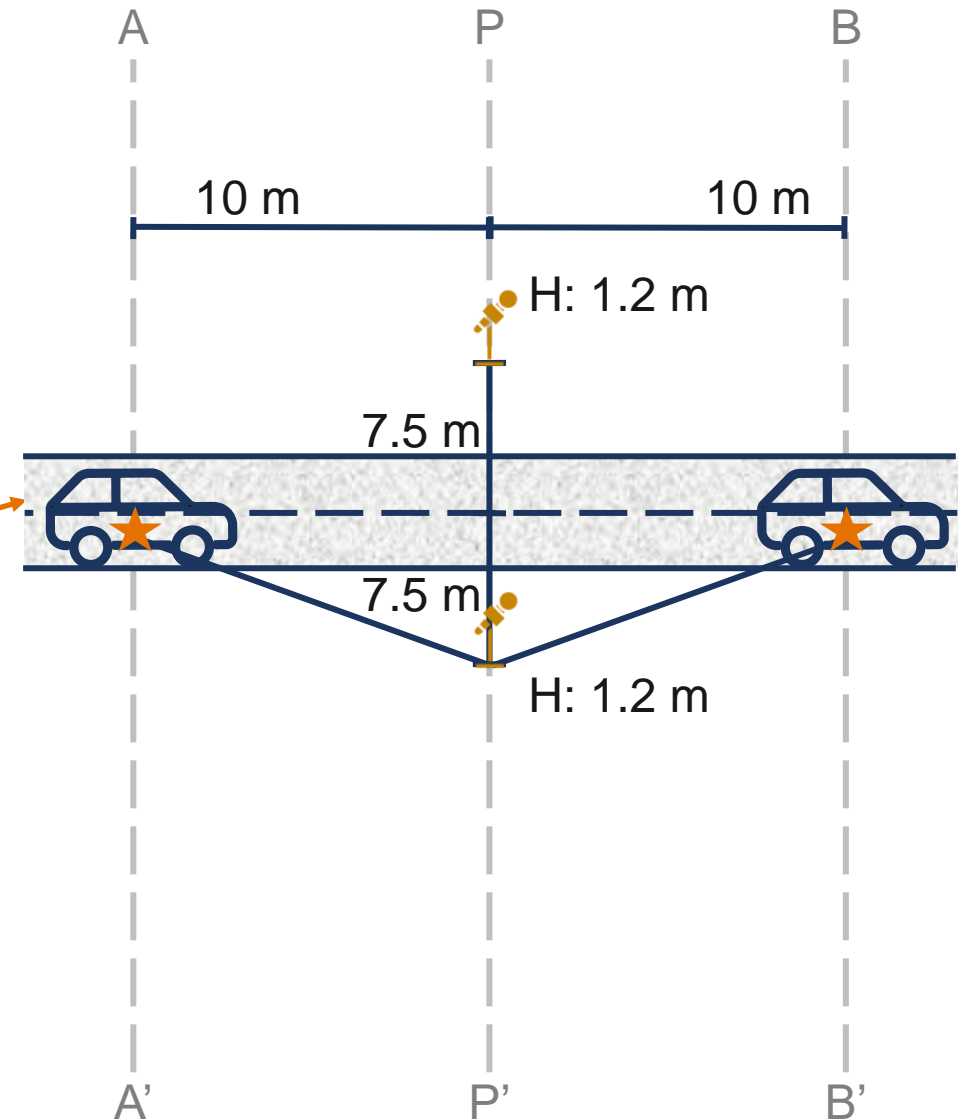

Possibilities for integrating sound emission changes

New coefficients from TA data – Procedure – Step 4

Which track width and position should be considered?

From R51.03

» “Calculation of acceleration”:

» “The speed either at AA' or PP' is defined as the vehicle speed when the reference point passes AA' ($v_{AA'}$) or PP' ($v_{PP'}$).“

» “The speed at BB' is defined when the rear of the vehicle passes BB' ($v_{BB'}$).“

$$a_{wot\ test} = \frac{\left(\frac{v_{BB'}}{3.6}\right)^2 - \left(\frac{v_{AA'}}{3.6}\right)^2}{2 \cdot (20 + l)}$$

Front engine: $l = l_{veh}$
Mid engine: $l = l_{veh} \cdot 0.5$
Rear engine: $l = 0\text{ m}$

» It can be assumed that $l_{veh} = 5\text{ m}$

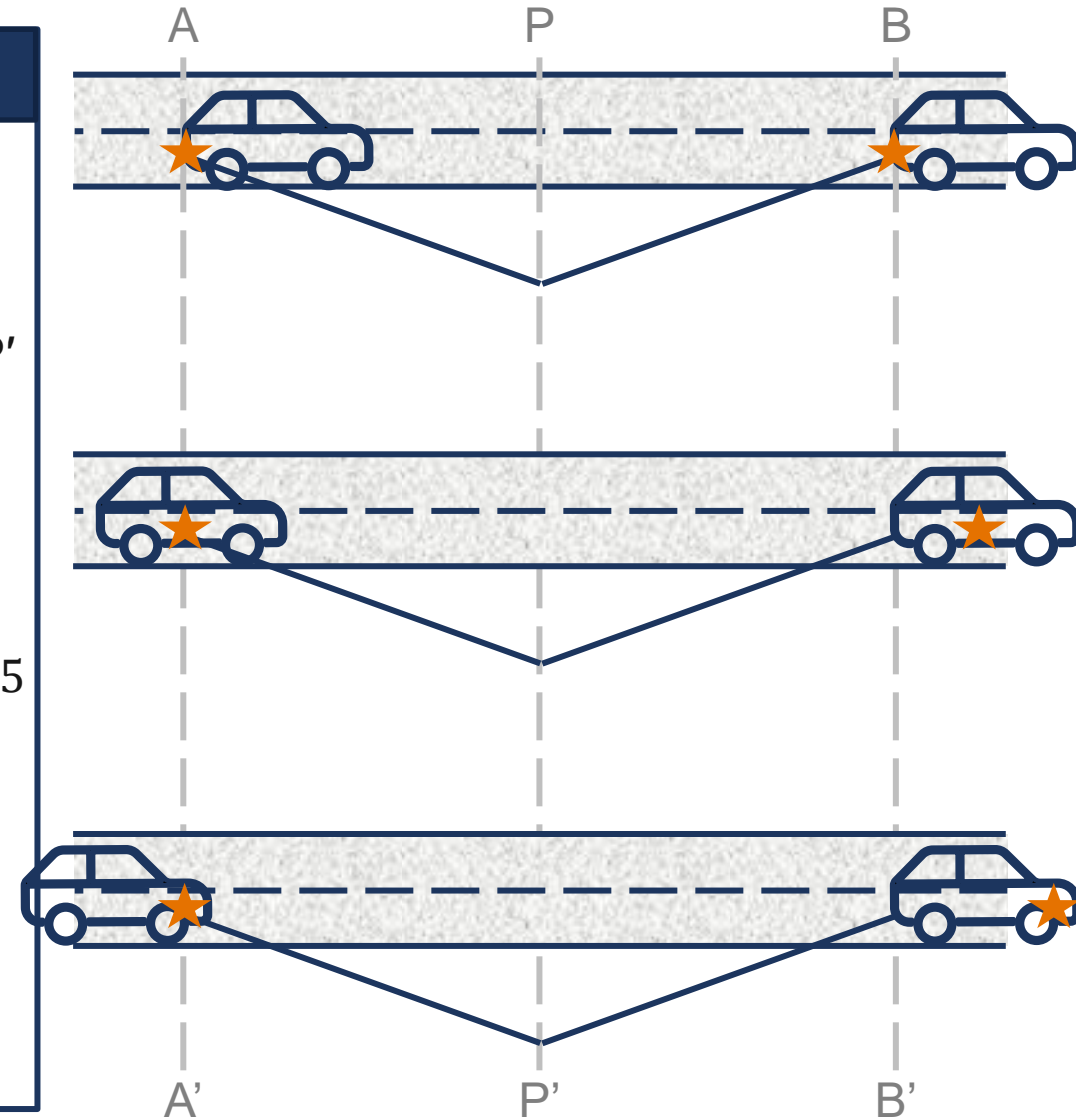

Possibilities for integrating sound emission changes

New coefficients from TA data – Procedure – Step 4

Which track width and position should be considered?

From R51.03

- » “Interpretation of results”:
 - » “[...] the maximum A-weighted sound pressure level indicated during each passage of the vehicle between the two lines AA' and BB' [...]”
- » Suggestion for front engine:
 - » Usage of the calculated acceleration from $v_{BB'}$ and $v_{AA'}$
 - » Track width to be considered: 25 m (symmetric)

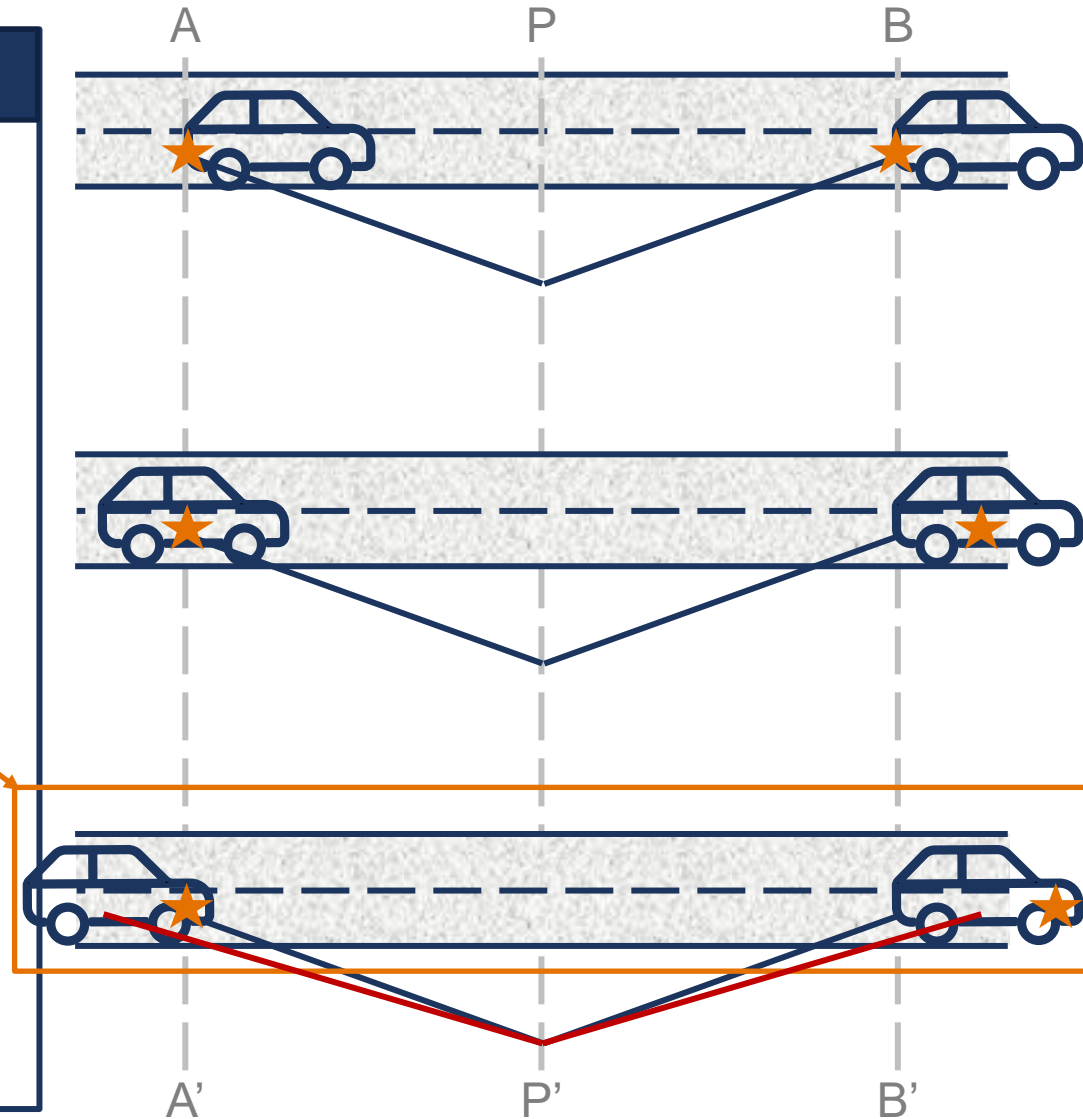
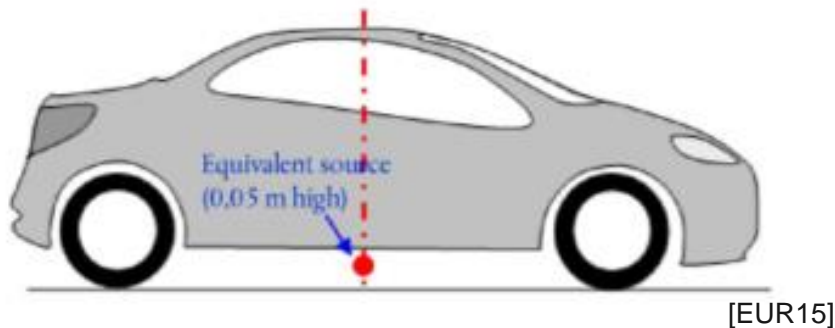

Motivation

- » Aim: Update CNOSSOS coefficients using type approval measurements (TA)
- » Procedure:
 1. Estimate calculation procedure to get SEL from TA
 2. Comprehend the CNOSSOS transfer functions (TFs) from point source (vehicle) to receiver (microphone)
 3. Rebuilding the TFs
 4. Identification of different conditions for TA compared to SPB reg. the TFs
 5. Adaption of the TFs (according to findings in 4.)
 6. Identification of different conditions for TA compared to SPB reg. the correction factors in CNOSSOS
 7. Estimation of coefficients for new vehicles

Transfer functions from L_W to SEL

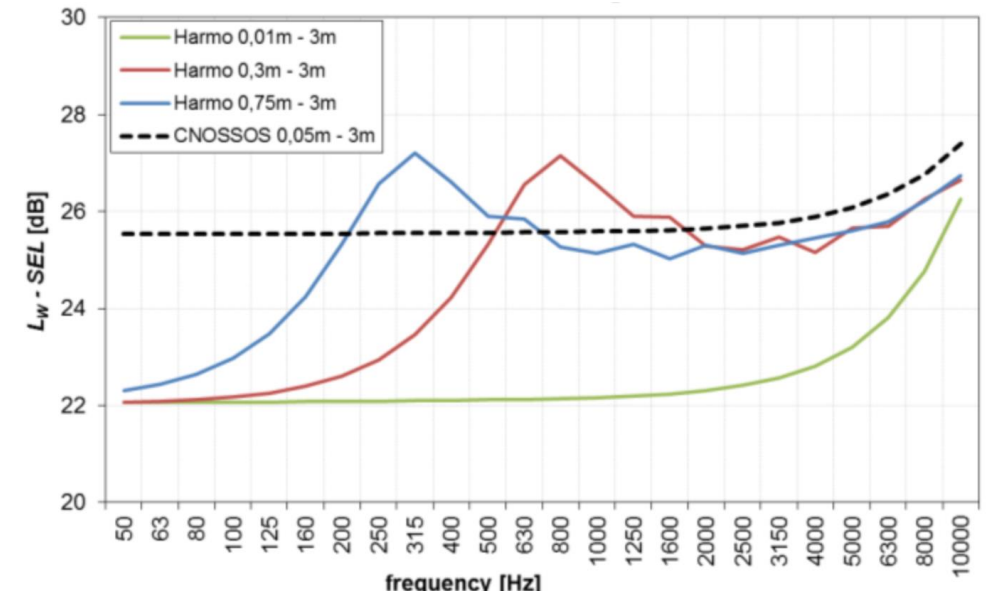

50 Hz	63 Hz	80 Hz	100 Hz	125 Hz	160 Hz	200 Hz	250 Hz	315 Hz	400 Hz	500 Hz	630 Hz
25.53	25.53	25.53	25.53	25.54	25.54	25.54	25.55	25.55	25.56	25.56	25.57
800 Hz	1 kHz	1.25 kHz	1.6 kHz	2 kHz	2.5 kHz	3.15 kHz	4 kHz	5 kHz	6.3 kHz	8 kHz	10 kHz
25.58	25.59	25.60	25.62	25.65	25.70	25.77	25.89	26.07	26.35	26.77	27.40

[BLO17] [PEE18]

Possibilities for integrating sound emission changes

New coefficients from TA data – Procedure – Step 5

Definition of two new TFs

- » General parameters
 - » Mic with distance $d = 7.5$ m and height $h_r = 1.2$ m
 - » Source height $h_s = 0.05$ m
 - » Track width $d_{track} = 25$ m (symmetric)
 - » Reflection $\Delta L = -3$ dB (from SEL to L_W)
 - » Atmospheric absorption for 15°C and 70% humidity
- » Variant 1 – Constant driving 50 km/h (crs)
 - » Speed $v_{AA'} = v_{BB'} = 50$ km/h
- » Variant 2 – Wide open throttle (wot)
 - » Speed $v_{PP'} = 50$ km/h
 - » Exemplary acceleration $a = 2$ m/s²
 - » For documentation only: The equation for calculating the vehicle trajectory are given in the appendix

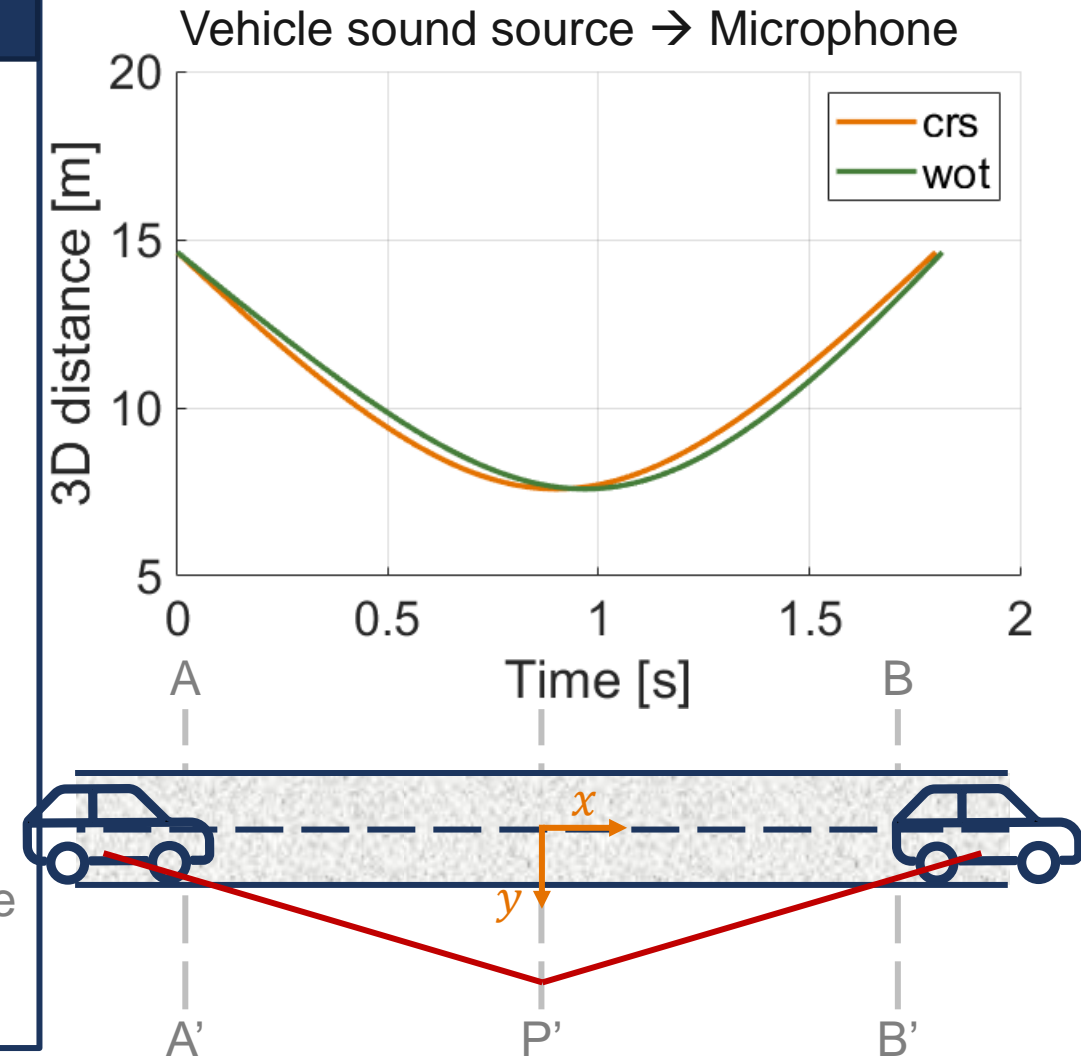

Possibilities for integrating sound emission changes

New coefficients from TA data – Procedure – Step 5

Definition of two new TFs

- » General parameters
 - » Mic with distance $d = 7.5$ m and height $h_r = 1.2$ m
 - » Source height $h_s = 0.05$ m
 - » Track width $d_{track} = 25$ m (symmetric)
 - » Reflection $\Delta L = -3$ dB (from SEL to L_W)
 - » Atmospheric absorption for 15°C and 70% humidity
- » Variant 1 – Constant driving 50 km/h (crs)
 - » Speed $v_{AA'} = v_{BB'} = 50$ km/h
- » Variant 2 – Wide open throttle (wot)
 - » Speed $v_{PP'} = 50$ km/h
 - » Exemplary acceleration $a = 2$ m/s²
 - » For documentation only: The equation for calculating the vehicle trajectory are given in the appendix

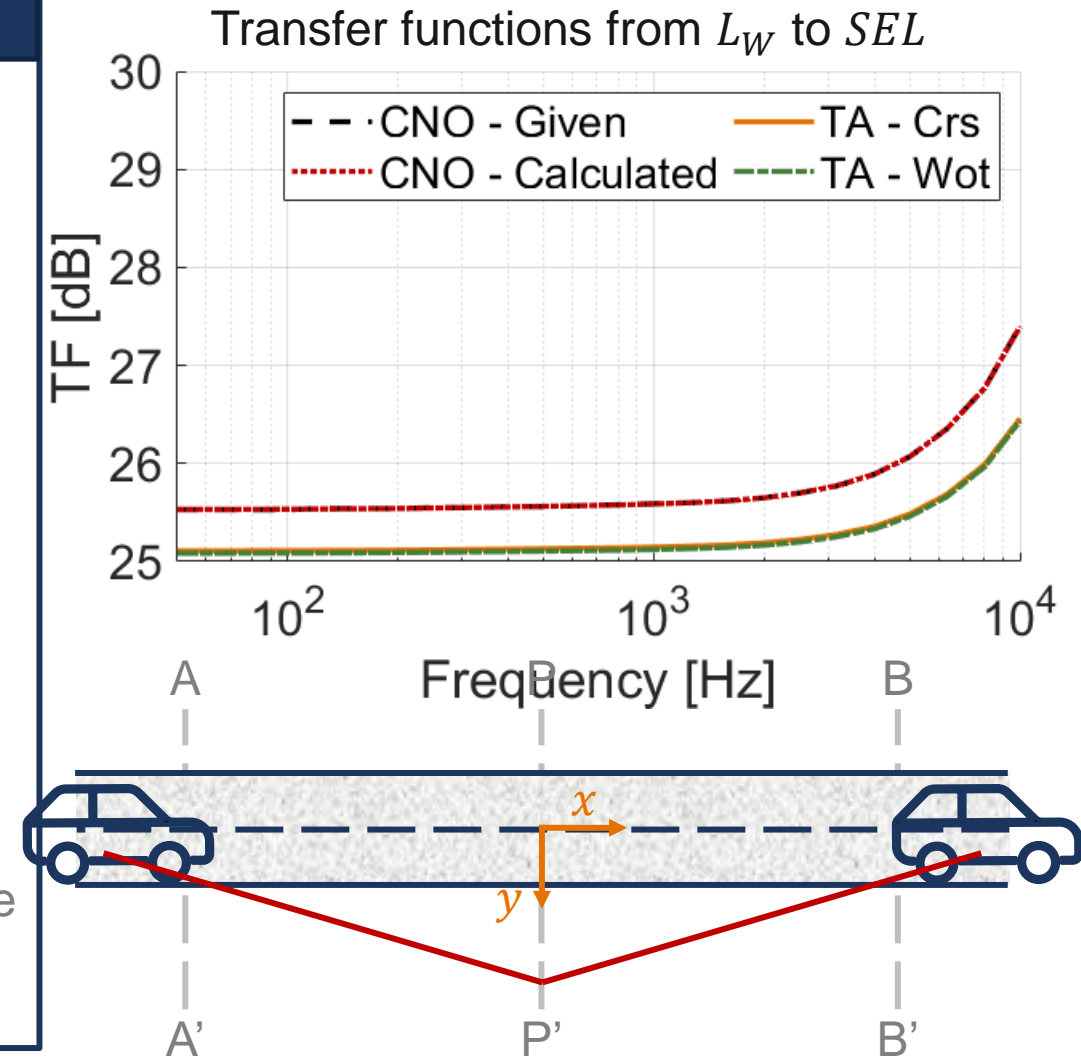

Motivation

- » Aim: Update CNOSSOS coefficients using type approval measurements (TA)
- » Procedure:
 1. Estimate calculation procedure to get SEL from TA
 2. Comprehend the CNOSSOS transfer functions (TFs) from point source (vehicle) to receiver (microphone)
 3. Rebuilding the TFs
 4. Identification of different conditions for TA compared to SPB reg. the TFs
 5. Adaption of the TFs (according to findings in 4.)
 6. Identification of different conditions for TA compared to SPB reg. the correction factors in CNOSSOS
 7. Estimation of coefficients for new vehicles

Transfer functions from L_W to SEL

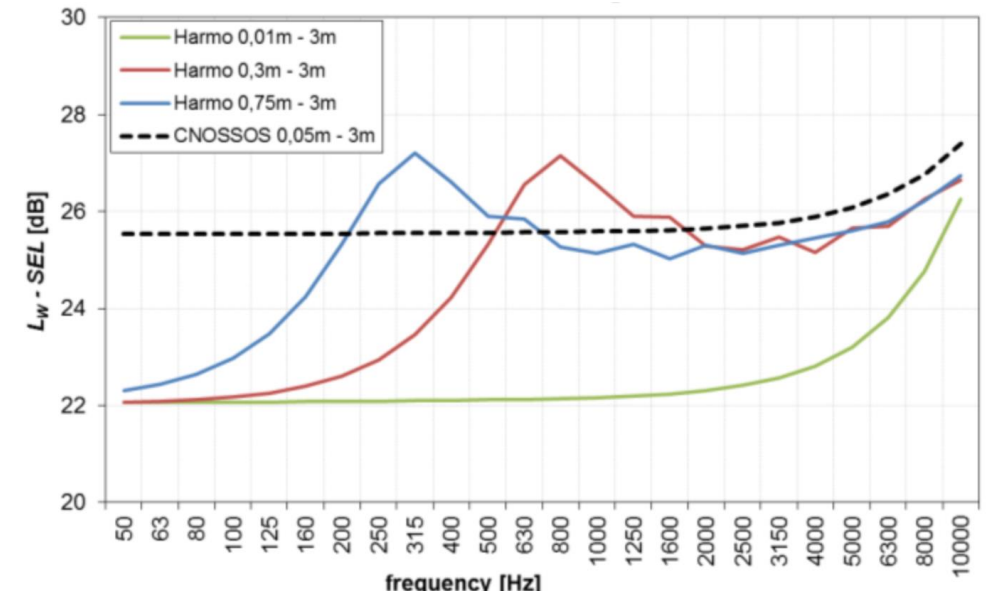

50 Hz	63 Hz	80 Hz	100 Hz	125 Hz	160 Hz	200 Hz	250 Hz	315 Hz	400 Hz	500 Hz	630 Hz
25.53	25.53	25.53	25.53	25.54	25.54	25.54	25.55	25.55	25.56	25.56	25.57
800 Hz	1 kHz	1.25 kHz	1.6 kHz	2 kHz	2.5 kHz	3.15 kHz	4 kHz	5 kHz	6.3 kHz	8 kHz	10 kHz
25.58	25.59	25.60	25.62	25.65	25.70	25.77	25.89	26.07	26.35	26.77	27.40

[BLO17] [PEE18]

Possibilities for integrating sound emission changes

New coefficients from TA data – Procedure – Step 6 – Flowchart

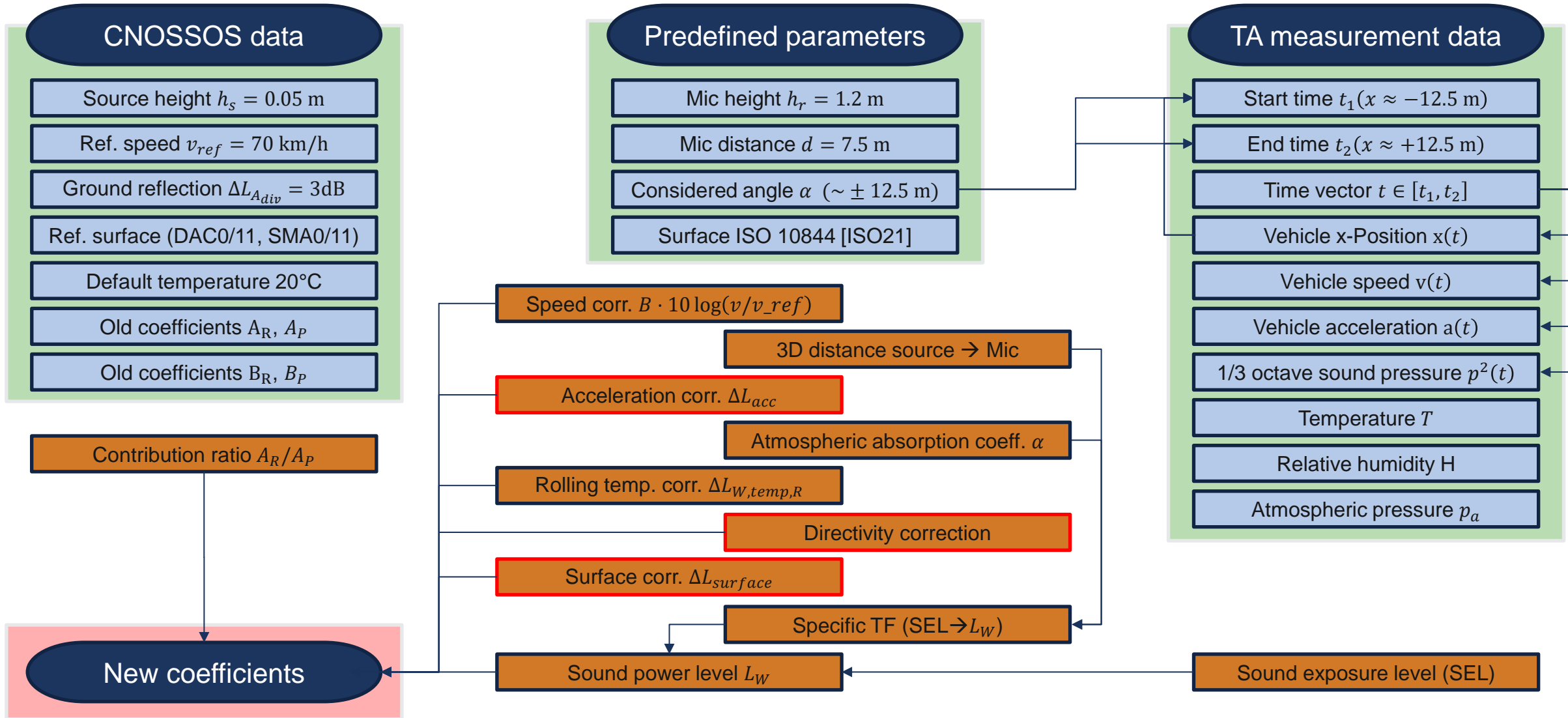

Possibilities for integrating sound emission changes

New coefficients from TA data – Procedure – Step 6 – Flowchart

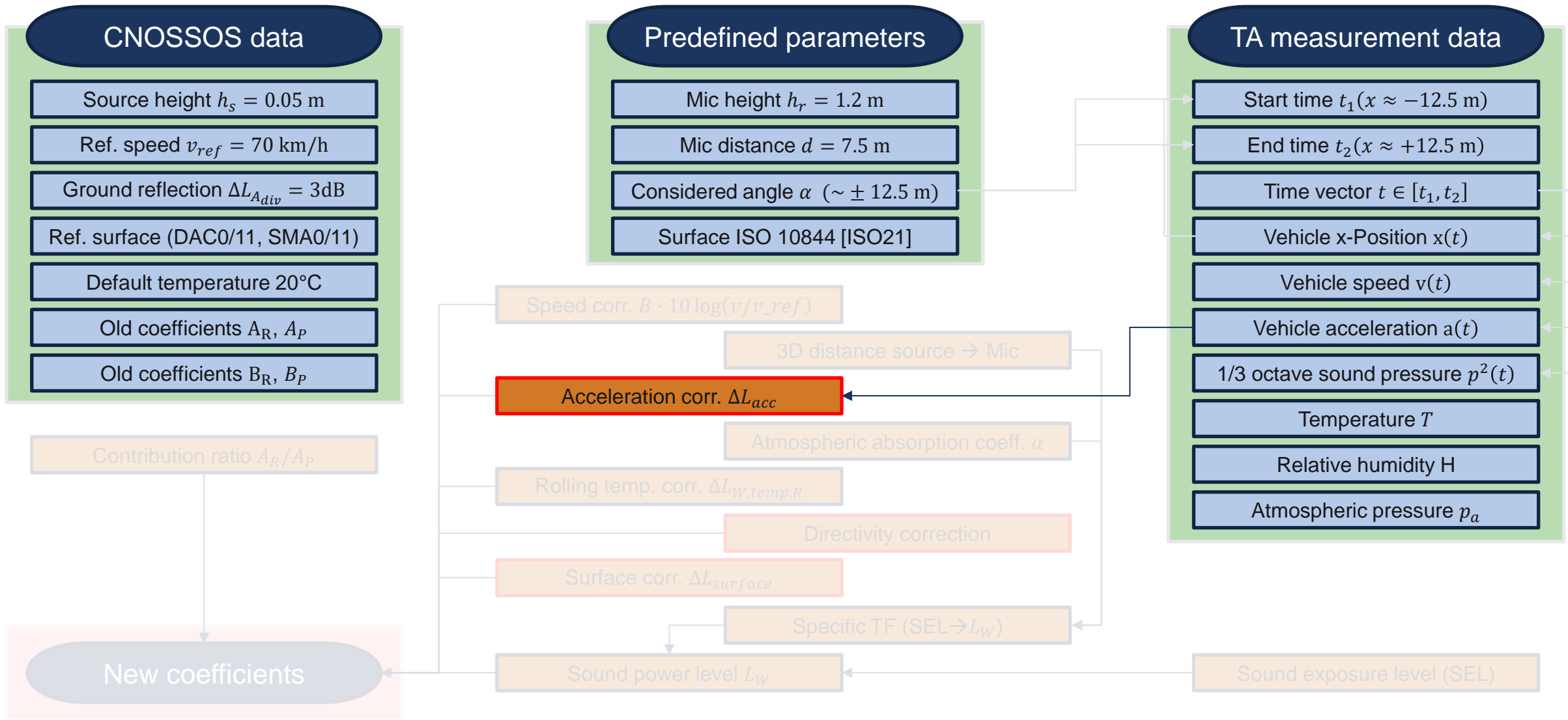

Acceleration issue

- » No suitable acceleration correction defined in CNOSSOS directive, only for crossings
 - » If accelerated pass-by measurements are to be taken into account, a method must be defined

» From CNOSSOS directive [EUR15] [EUR21b]

- » $\Delta L_{WR,i,m} = \Delta L_{WR,road,i,m} + \Delta L_{WR,studdedtyres,i,m} + \Delta L_{WR,acc,i,m} + \Delta L_{W,temp}$
- » $\Delta L_{WP,i,m} = \Delta L_{WP,road,i,m} + \Delta L_{WP,grad,i,m} + \Delta L_{WP,acc,i,m}$

» $\Delta L_{WR,acc,i,m} = C_{R,m,k} \times \text{Max} \left(1 - \frac{|x|}{100}; 0 \right)$

» $\Delta L_{WP,acc,i,m} = C_{P,m,k} \times \text{Max} \left(1 - \frac{|x|}{100}; 0 \right)$

» $k = 1$ for crossings with traffic lights

» $k = 2$ for crossings with roundabouts

Table F-3
Coefficients $C_{R,m,k}$ and $C_{P,m,k}$ for acceleration and deceleration

Category	k	Cr	Cp
1	1 = crossing	- 4,5	5,5
	2 = roundabout	- 4,4	3,1
2	1 = crossing	- 4	9
	2 = roundabout	- 2,3	6,7
3	1 = crossing	- 4	9
	2 = roundabout	- 2,3	6,7
4a	1 = crossing	0	0
	2 = roundabout	0	0
4b	1 = crossing	0	0
	2 = roundabout	0	0
5	1 = crossing		
	2 = roundabout		

[EUR15]

Possibilities for integrating sound emission changes

New coefficients from TA data – Procedure – Step 6 – Flowchart

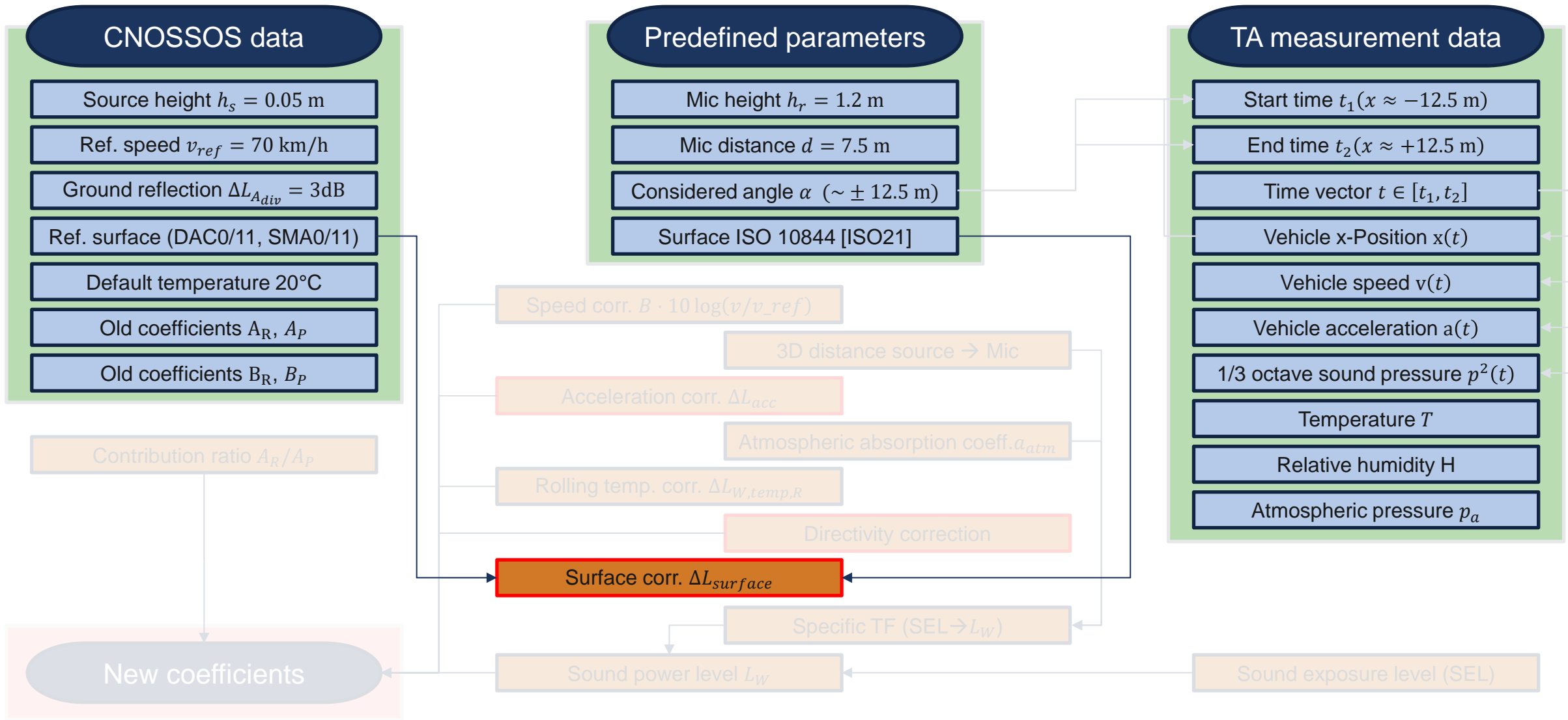

Possibilities for integrating sound emission changes

New coefficients from TA data – Procedure – Step 6

Road surface correction

» Correction not available for TA road surface according to ISO 10844 [ISO21], only for:

» 1/2/3-layer ZOAB, SMA-NL5/8, brushed down concrete, [...], quiet hard elements, thin layer A, thin layer B

» Reference surface in CNOSSOS:

» An average of dense asphalt concrete 0/11 and stone mastic asphalt 0/11, between 2 and 7 years old and in a representative maintenance condition

» From CNOSSOS directive [EUR15] [EUR21b]

$$\Delta L_{WR,i,m} = \Delta L_{WR,road,i,m} + \Delta L_{WR,studdedtyres,i,m} + \Delta L_{WR,acc,i,m} + \Delta L_{W,temp}$$

$$\Delta L_{WP,i,m} = \Delta L_{WP,road,i,m} + \Delta L_{WP,grad,i,m} + \Delta L_{WP,acc,i,m}$$

$$\Delta L_{WR,road,i,m} = \alpha_{i,m} + \beta_m \times \log(v/v_{ref})$$

$$\Delta L_{WP,road,i,m} = \min\{\alpha_{i,m}; 0\}$$

Coefficients $\alpha_{i,m}$ and β_m for road surface

Description	Min speed at which it is valid [km/h]	Maximum speed at which it is valid [km/h]	Category	$\alpha_{i,m}$ (63 Hz)	$\alpha_{i,m}$ (125 Hz)	$\alpha_{i,m}$ (250 Hz)	$\alpha_{i,m}$ (500 Hz)	$\alpha_{i,m}$ (1 kHz)	$\alpha_{i,m}$ (2 kHz)	$\alpha_{i,m}$ (4 kHz)	$\alpha_{i,m}$ (8 kHz)	β_m
Reference road surface	—	—	1	0,0	0,0	0,0	0,0	0,0	0,0	0,0	0,0	0,0
			2	0,0	0,0	0,0	0,0	0,0	0,0	0,0	0,0	0,0
			3	0,0	0,0	0,0	0,0	0,0	0,0	0,0	0,0	0,0
			4a	0,0	0,0	0,0	0,0	0,0	0,0	0,0	0,0	0,0
			4b	0,0	0,0	0,0	0,0	0,0	0,0	0,0	0,0	0,0
1-layer ZOAB	50	130	1	0,5	3,3	2,4	3,2	-1,3	-3,5	-2,6	0,5	-6,5
			2	0,9	1,4	1,8	-0,4	-5,2	-4,6	-3,0	-1,4	0,2
			3	0,9	1,4	1,8	-0,4	-5,2	-4,6	-3,0	-1,4	0,2
			4a	0,0	0,0	0,0	0,0	0,0	0,0	0,0	0,0	0,0
			4b	0,0	0,0	0,0	0,0	0,0	0,0	0,0	0,0	0,0
2-layer ZOAB	50	130	1	0,4	2,4	0,2	-3,1	-4,2	-6,3	-4,8	-2,0	-3,0
			2	0,4	0,2	-0,7	-5,4	-6,3	-6,3	-4,7	-3,7	4,7
			3	0,4	0,2	-0,7	-5,4	-6,3	-6,3	-4,7	-3,7	4,7
			4a	0,0	0,0	0,0	0,0	0,0	0,0	0,0	0,0	0,0
			4b	0,0	0,0	0,0	0,0	0,0	0,0	0,0	0,0	0,0
2-layer ZOAB (fine)	80	130	1	-1,0	1,7	-1,5	-5,3	-6,3	-8,5	-5,3	-2,4	-0,1
			2	1,0	0,1	-1,8	-5,9	-6,1	-6,7	-4,8	-3,8	-0,8
			3	1,0	0,1	-1,8	-5,9	-6,1	-6,7	-4,8	-3,8	-0,8
			4a	0,0	0,0	0,0	0,0	0,0	0,0	0,0	0,0	0,0
			4b	0,0	0,0	0,0	0,0	0,0	0,0	0,0	0,0	0,0

[EUR15]

Possibilities for integrating sound emission changes

New coefficients from TA data – Procedure – Step 6 – Flowchart

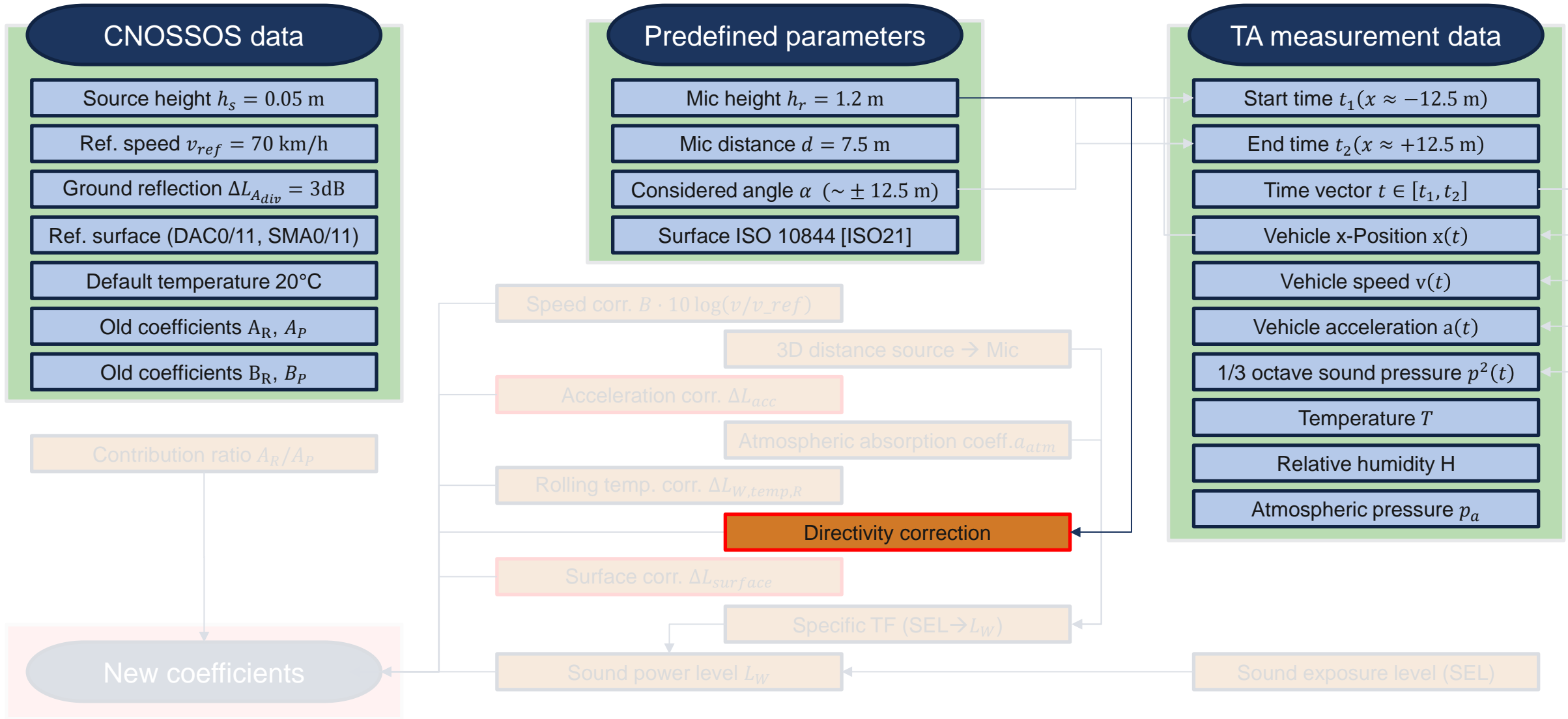

Road surface issue

- » **Difference in microphone heights CNOSSOS vs TA**
 - » This could lead to differences in the measured levels from vertical directivity
- » **[JON04] regarding full vehicle (rolling & propulsion):**
 - » „At present there is none [current official models regarding directivity] including complete directivity data“
 - » Regarding the vertical directivity it is stated:
 - » „The results show that there is little directivity in the vertical plane up to about 45° to the horizontal plane. After that the sound power level decreases up to about 5dB.“

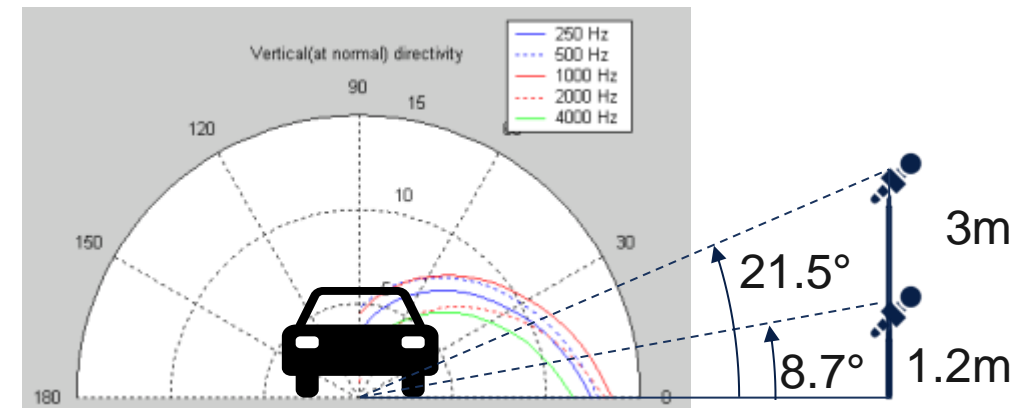

[JON04]

Vertical directivity

- » **Difference in microphone heights CNOSSOS vs TA**
 - » This could lead to differences in the measured levels from vertical directivity
- » **[JON04] regarding full vehicle (rolling & propulsion):**
 - » „At present there is none [current official models regarding directivity] including complete directivity data“
 - » Regarding the vertical directivity it is stated:
 - » „The results show that there is little directivity in the vertical plane up to about 45° to the horizontal plane. After that the sound power level decreases up to about 5dB.“
- » **The level ΔL difference for both microphone heights at 1kHz:**
 - » $\Delta L_{1kHz} \approx 1.3$ dB
 - » The directivity data indicates that the actual coefficients are even lower

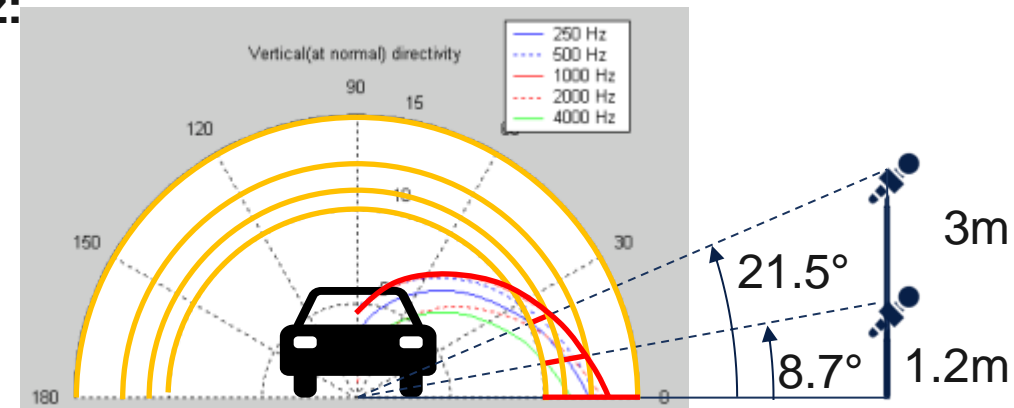

[JON04]

Possibilities for integrating sound emission changes

New coefficients from TA data – Procedure – Step 6 – Flowchart

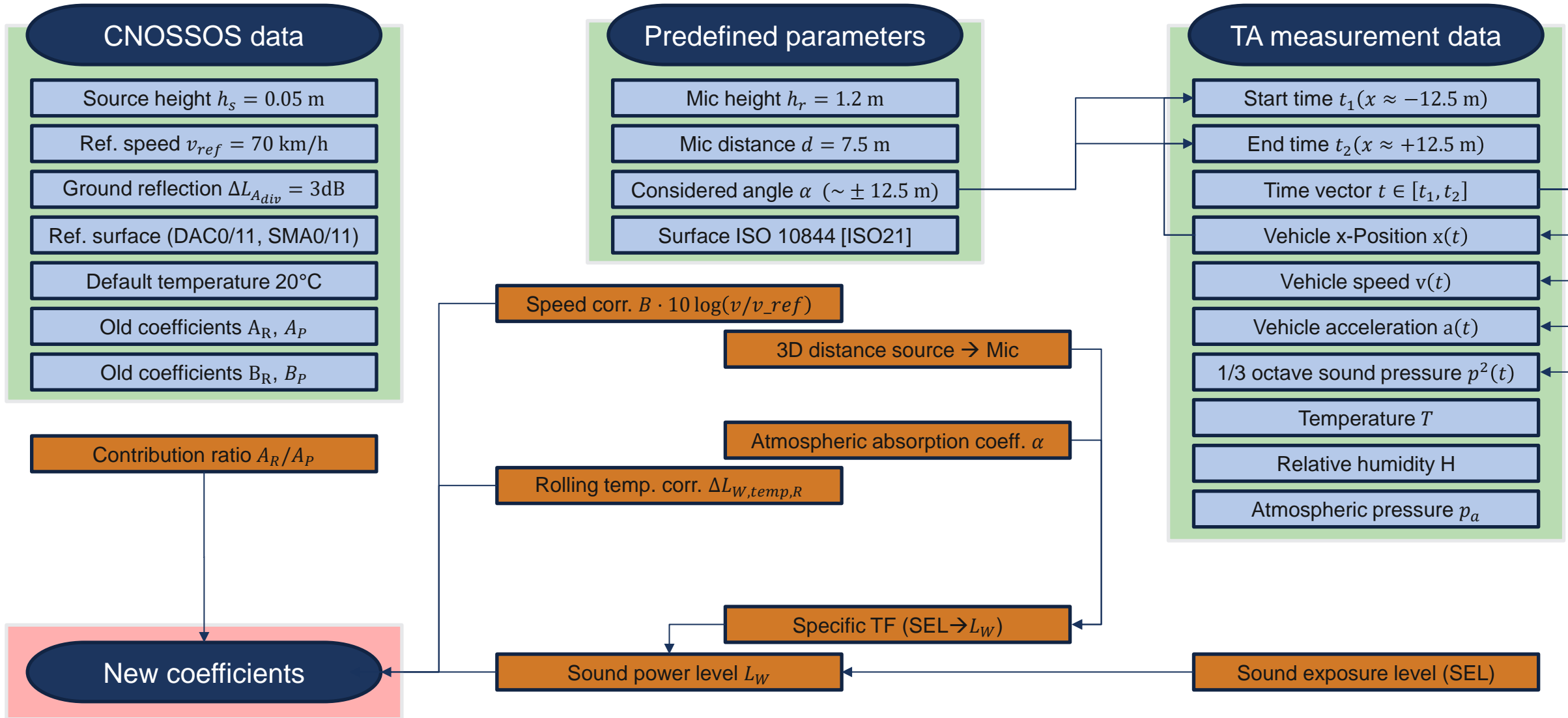

Possibilities for integrating sound emission changes

New coefficients from TA data – Procedure – Step 6 – Flowchart

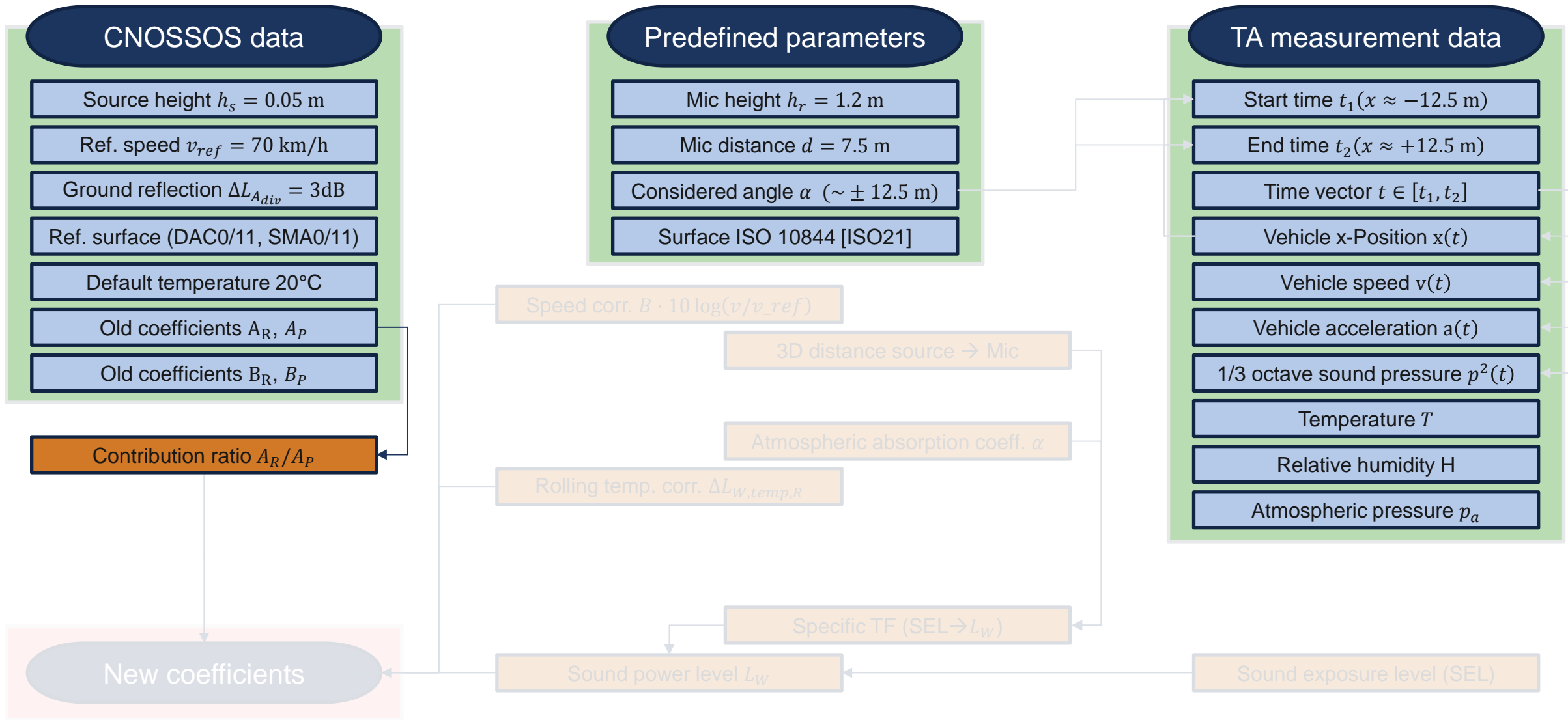

Possibilities for integrating sound emission changes

New coefficients from TA data – Procedure – Step 6 – Flowchart

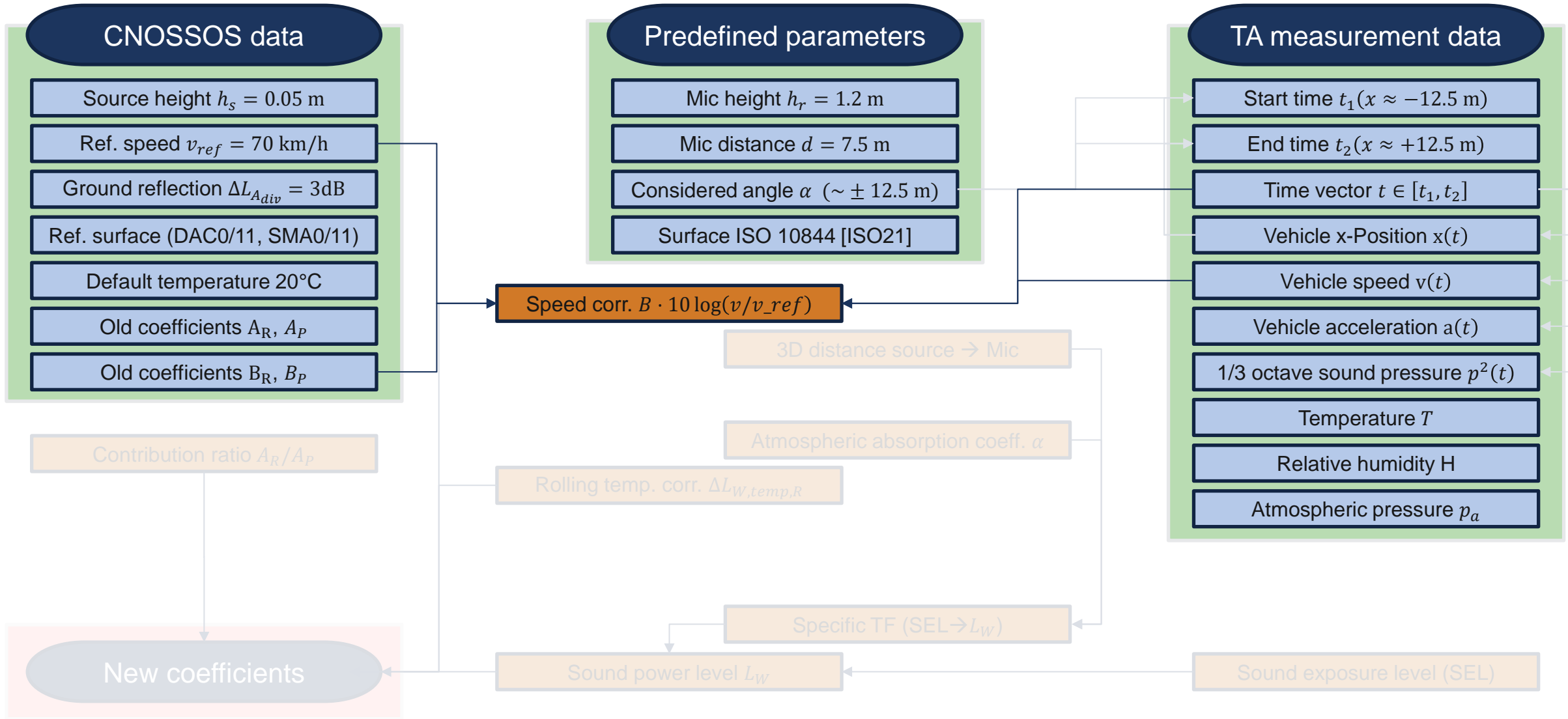

Possibilities for integrating sound emission changes

New coefficients from TA data – Procedure – Step 6 – Flowchart

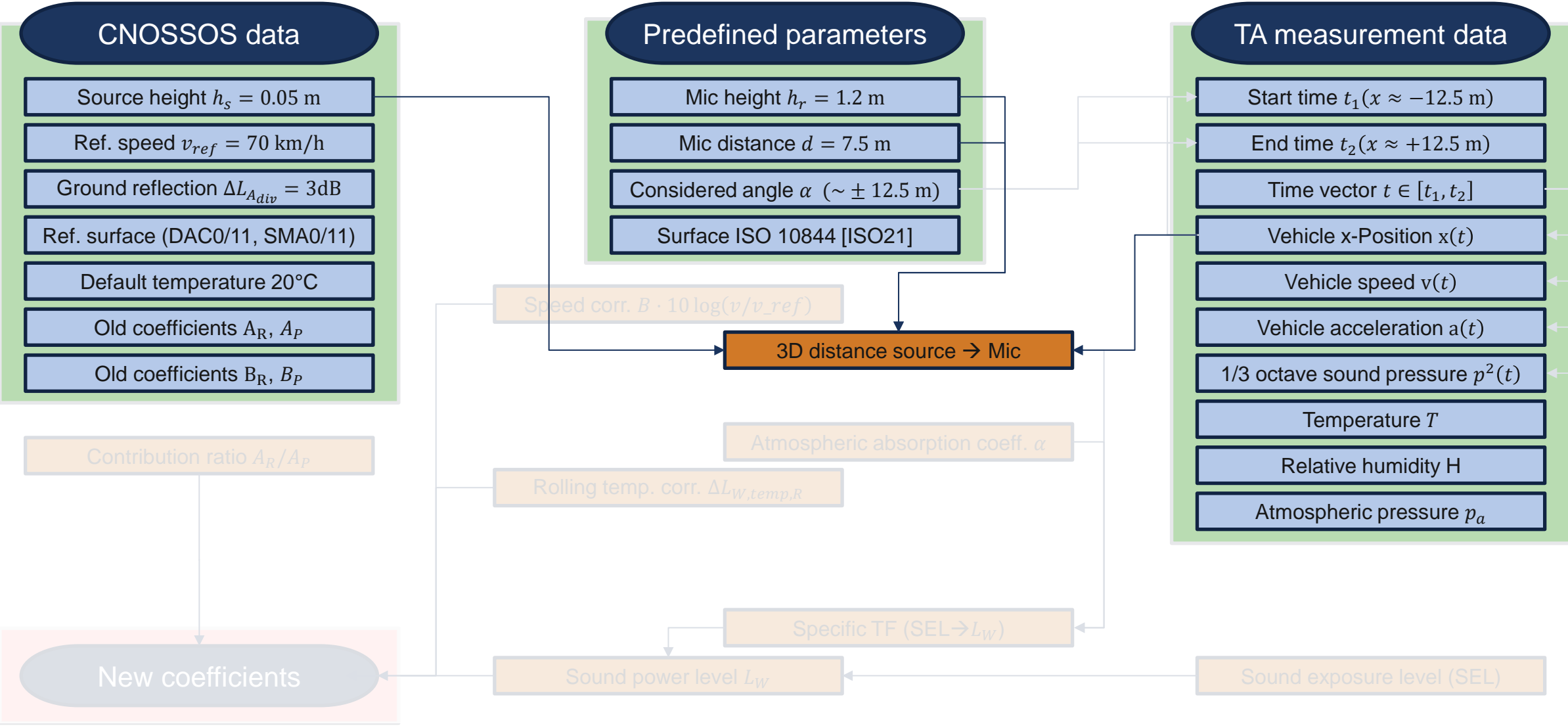

Possibilities for integrating sound emission changes

New coefficients from TA data – Procedure – Step 6 – Flowchart

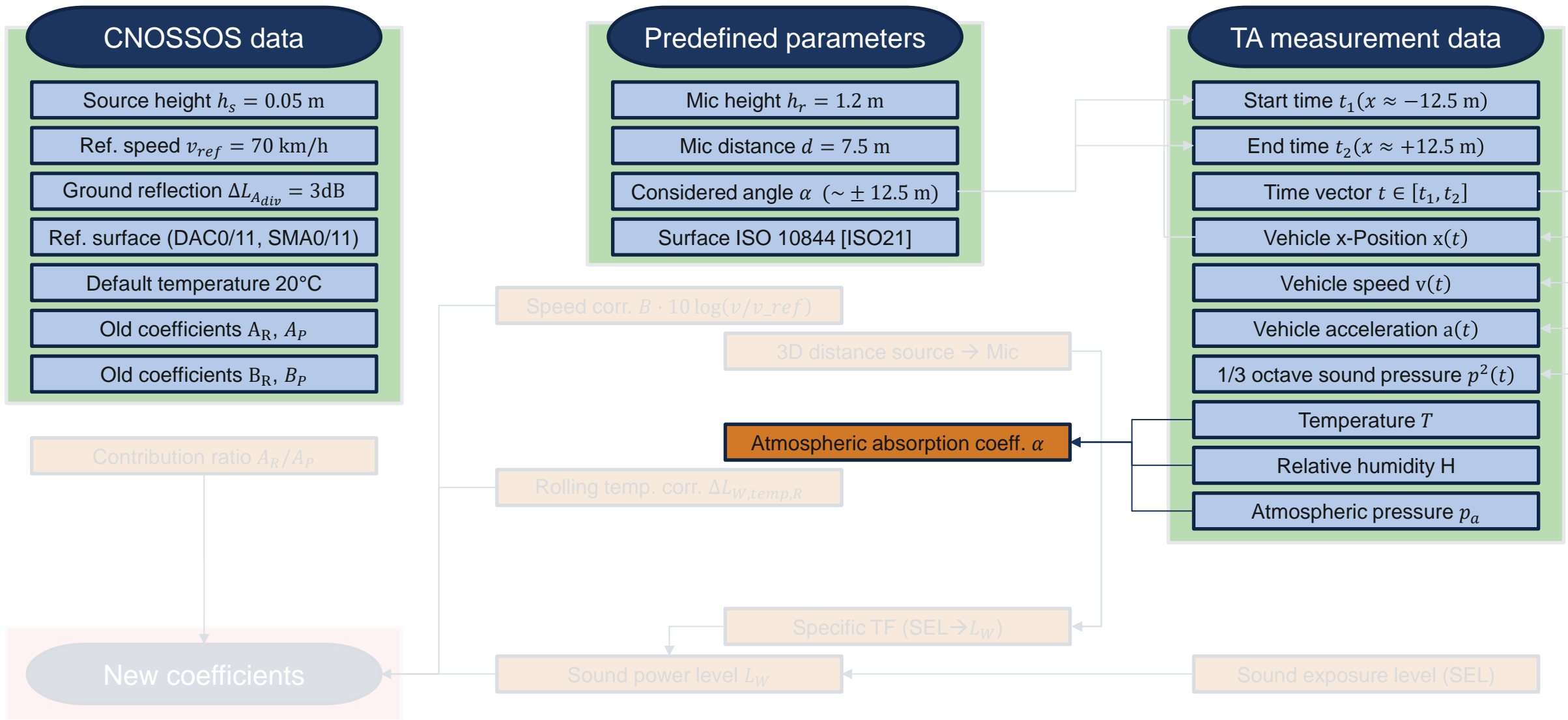

Attenuation coefficient

» From CNOSSOS directive [EUR15] based on ISO 9613-1 [ISO93]

» TFs and atmospheric absorption given for reference conditions ($T = 15^\circ\text{C}$, $h_r = 70\%$, $p_r = 101.325 \text{ kPa}$)

» From [ISO93]

» Relaxation frequencies

» Oxygen:
$$f_{rO} = \frac{p_a}{p_r} \left(24 + 4.04 \times 10^4 h \frac{0.02+h}{0.391+h} \right)$$

» Nitrogen:
$$f_{rN} = \frac{p_a}{p_r} \left(\frac{T}{T_0} \right)^{-1/2} \times \left(9 + 280h \exp \left\{ -4.170 \left[\left(\frac{T}{T_0} \right)^{-1/3} - 1 \right] \right\} \right)$$

» Attenuation coefficient α

»
$$\alpha = 8.686 f^2 \left(\left[1.84 \times 10^{-11} \left(\frac{p_a}{p_r} \right)^{-1} \left(\frac{T}{T_0} \right)^{-1/2} \right] + \left(\frac{T}{T_0} \right)^{-5/2} \times \left\{ 0.01275 \left[\exp \left(-\frac{2239.1}{T} \right) \right] \left[f_{rO} + \frac{f^2}{f_{rO}} \right]^{-1} + 0.1068 \left[\exp \left(-\frac{3352.0}{T} \right) \right] \left[f_{rN} + \frac{f^2}{f_{rN}} \right]^{-1} \right\} \right)$$

» Conversion of relative humidity h_r to molar concentration of water vapor h

» $T_{01} = 0.01^\circ\text{C}$ and $p_r = 101.325 \text{ kPa}$

» $C = -6.8246(T_{01}/T)^{1.261} + 4.6151$

» $p_{sat} = p_r 10^C$

» $h = h_r (p_{sat}/p_r) / (p_a/p_r)$

CNOSSOS:
Atmospheric absorption
 $A_{atm} = \alpha \cdot d/1000$

Possibilities for integrating sound emission changes

New coefficients from TA data – Procedure – Step 6 – Flowchart

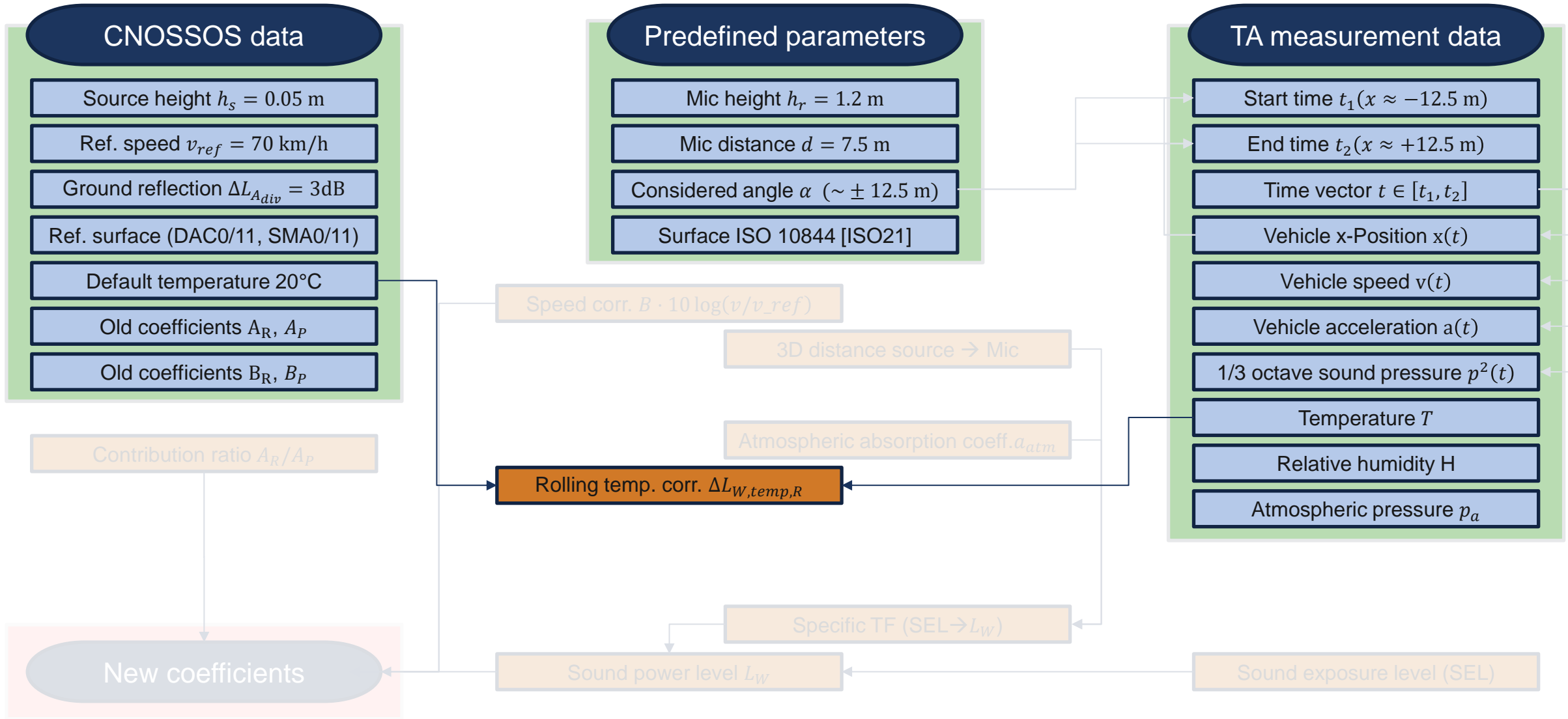

Road surface temperature

» From CNOSSOS directive [EUR15] [EUR21b]

» $\Delta L_{WR,i,m} = \Delta L_{WR,road,i,m} + \Delta L_{WR,studdedtyres,i,m} + \Delta L_{WR,acc,i,m} + \Delta L_{W,temp}$

» It is explicitly mentioned, that the air temperature should be used, not the road surface temperature

» With increasing temperature, the rolling noise gets quieter:

» $\Delta L_{W,temp} = K_m \times (\tau_{ref} - \tau)$

» $K_{m=1} = 0.08 \text{ dB/}^\circ\text{C}$

» $K_{m=2} = K_{m=3} = 0.04 \text{ dB/}^\circ\text{C}$

» $\tau_{ref} = 20^\circ\text{C}$ (Side note: For atmospheric absorption A_{atm} in CNOSSOS, the reference temperature is 15°C)

Possibilities for integrating sound emission changes

New coefficients from TA data – Procedure – Step 6 – Flowchart

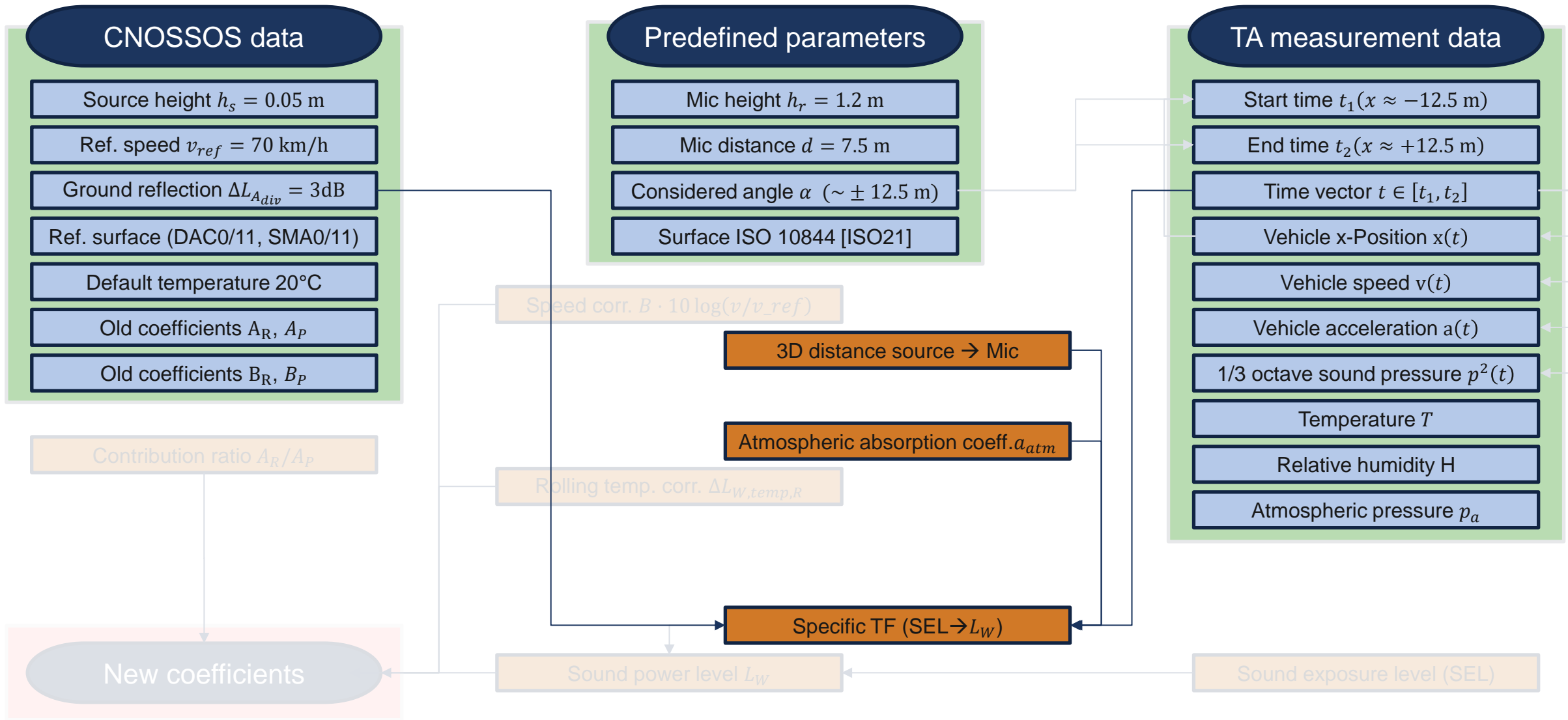

Possibilities for integrating sound emission changes

New coefficients from TA data – Procedure – Step 6 – Flowchart

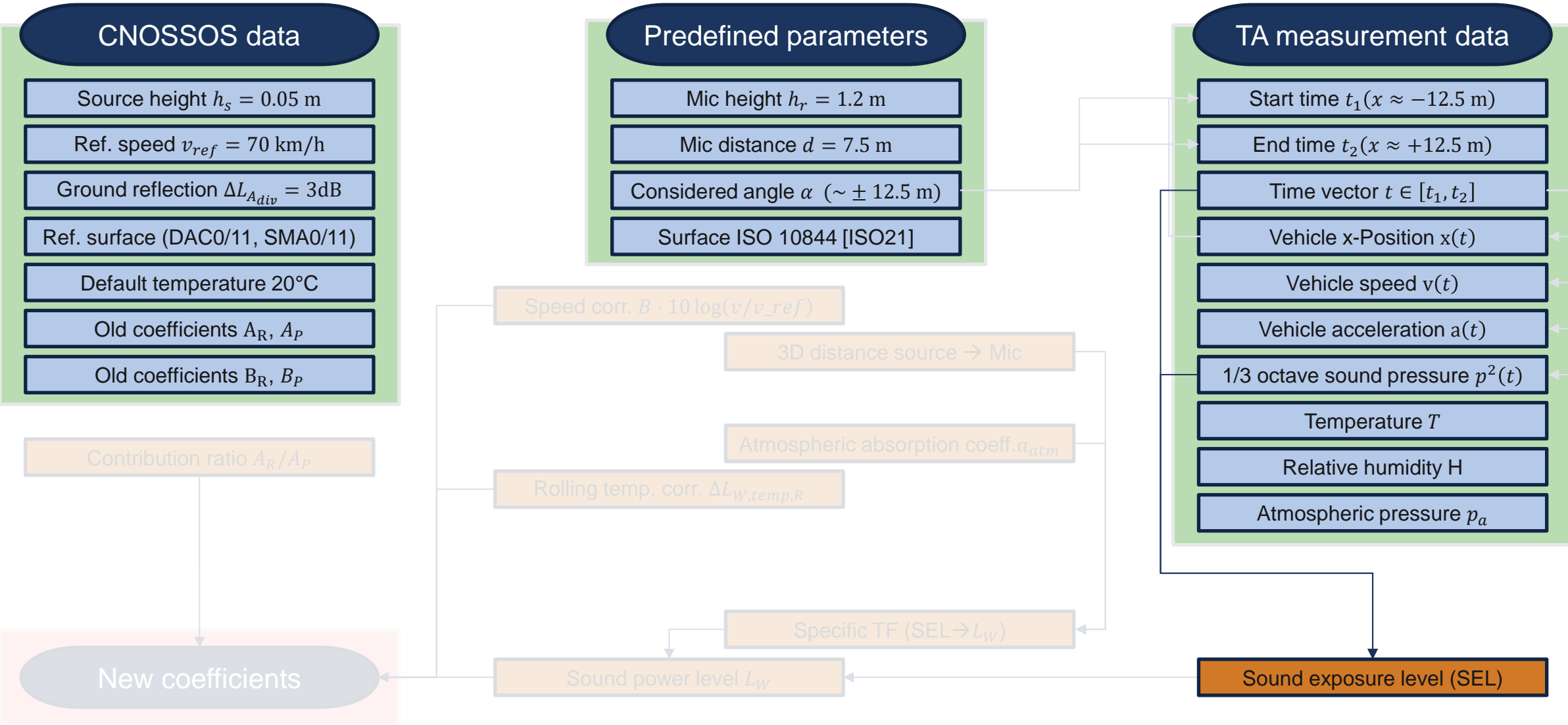

Possibilities for integrating sound emission changes

New coefficients from TA data – Procedure – Step 6 – Flowchart

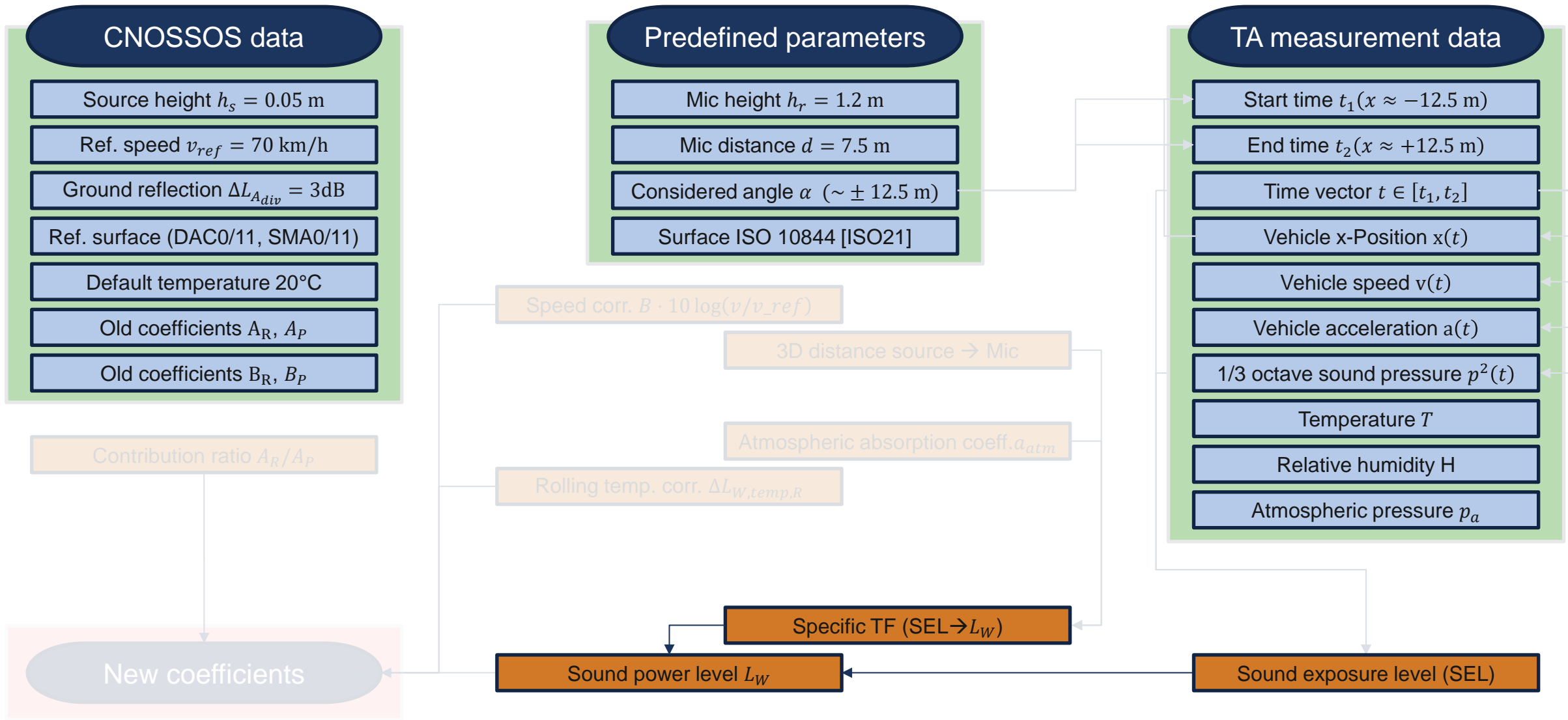

Possibilities for integrating sound emission changes

New coefficients from TA data – Procedure – Step 6 – Flowchart

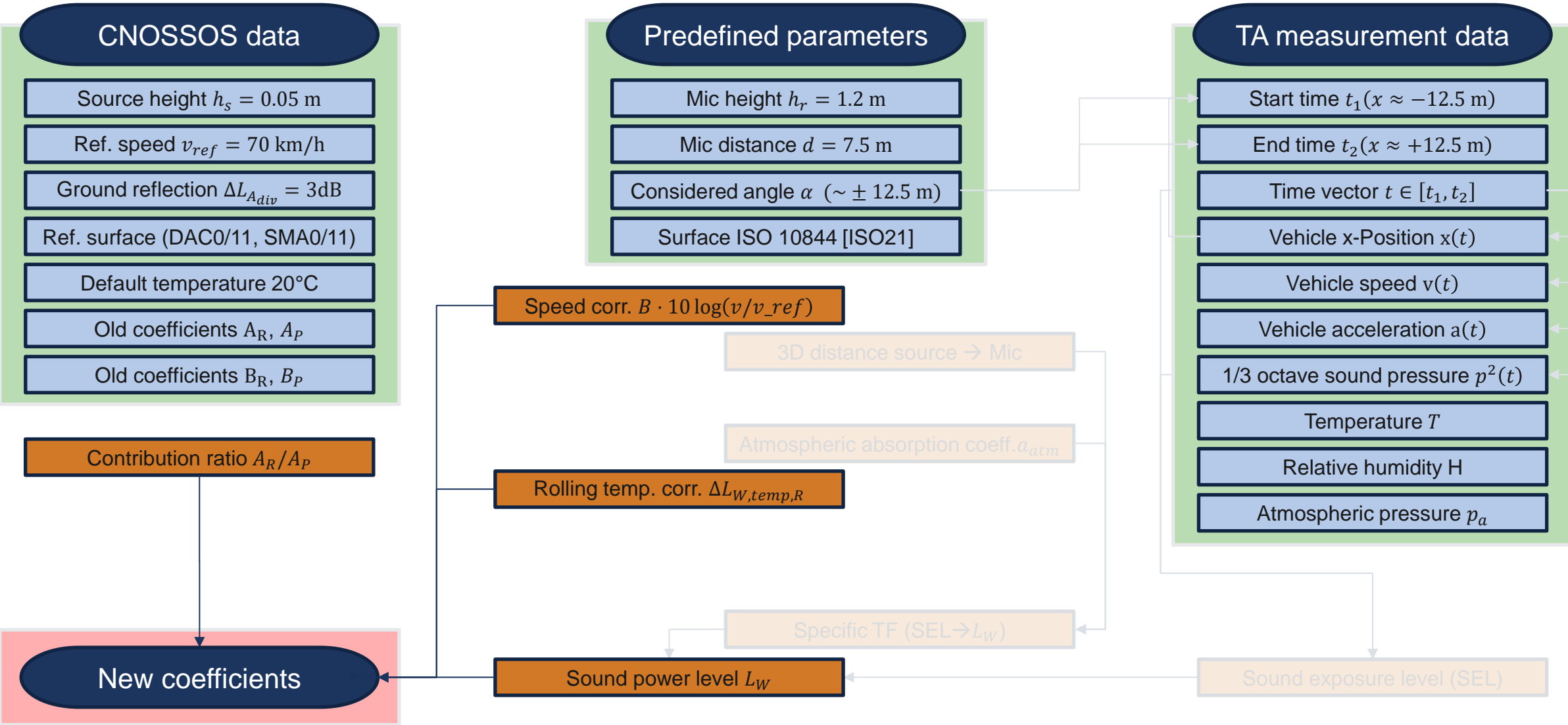

Motivation

- » Aim: Update CNOSSOS coefficients using type approval measurements (TA)
- » Procedure:
 1. Estimate calculation procedure to get SEL from TA
 2. Comprehend the CNOSSOS transfer functions (TFs) from point source (vehicle) to receiver (microphone)
 3. Rebuilding the TFs
 4. Identification of different conditions for TA compared to SPB reg. the TFs
 5. Adaption of the TFs (according to findings in 4.)
 6. Identification of different conditions for TA compared to SPB reg. the correction factors in CNOSSOS
 7. Estimation of coefficients for new vehicles

Transfer functions from L_W to SEL

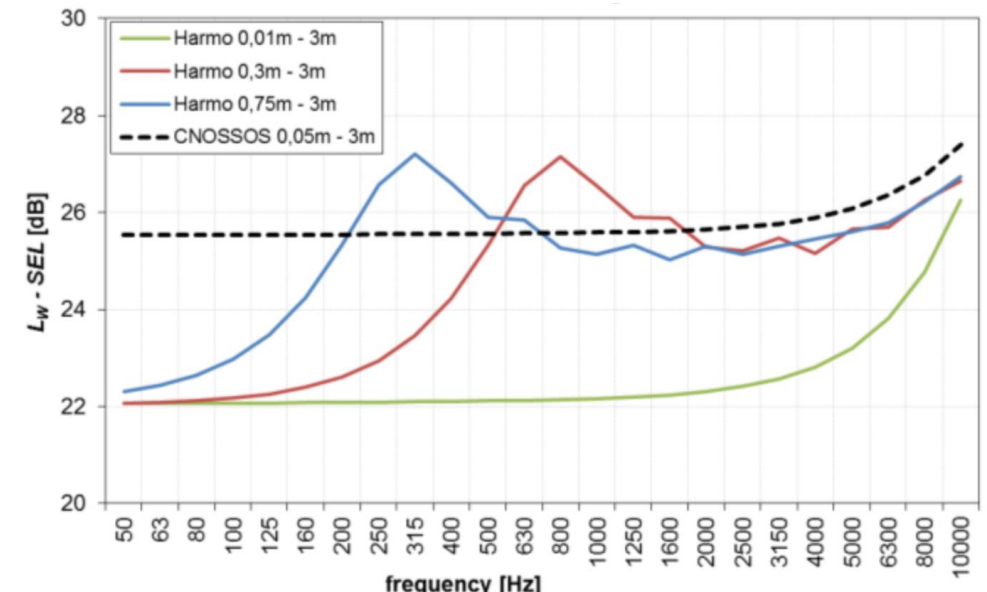

50 Hz	63 Hz	80 Hz	100 Hz	125 Hz	160 Hz	200 Hz	250 Hz	315 Hz	400 Hz	500 Hz	630 Hz
25.53	25.53	25.53	25.53	25.54	25.54	25.54	25.55	25.55	25.56	25.56	25.57
800 Hz	1 kHz	1.25 kHz	1.6 kHz	2 kHz	2.5 kHz	3.15 kHz	4 kHz	5 kHz	6.3 kHz	8 kHz	10 kHz
25.58	25.59	25.60	25.62	25.65	25.70	25.77	25.89	26.07	26.35	26.77	27.40

[BLO17] [PEE18]

Possibilities for integrating sound emission changes

New coefficients from TA data – Procedure – Step 7



Coefficients

V1/V2: Vehicle 1/2

G4/G5: Gear 4/5

Note: various runs considered

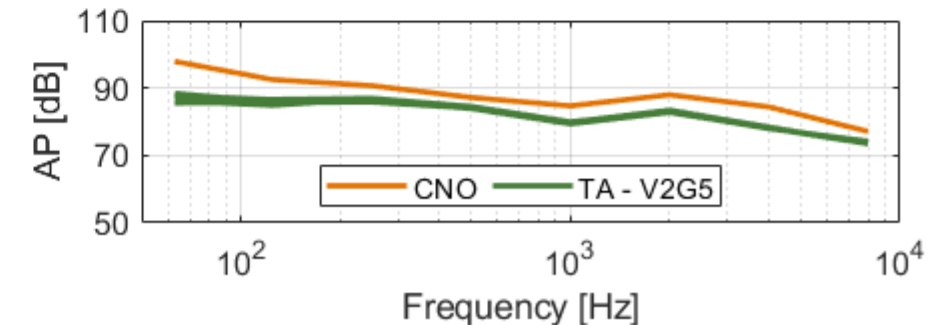
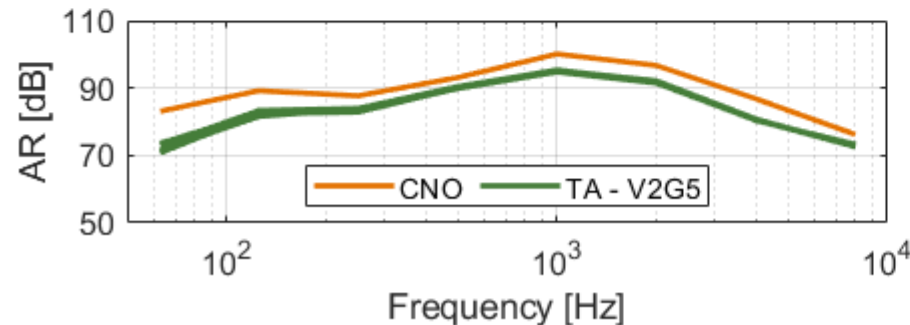
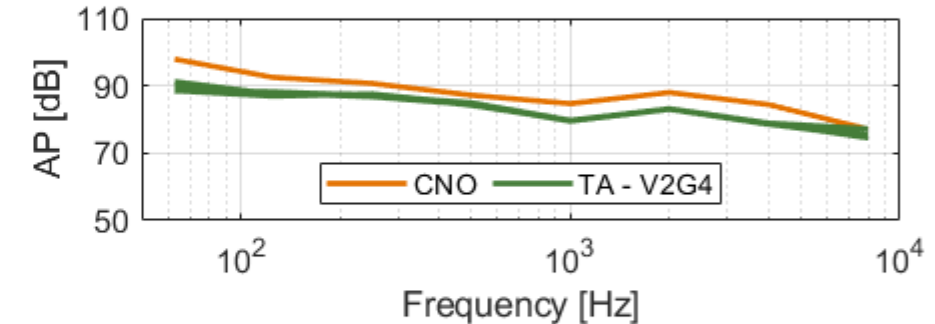
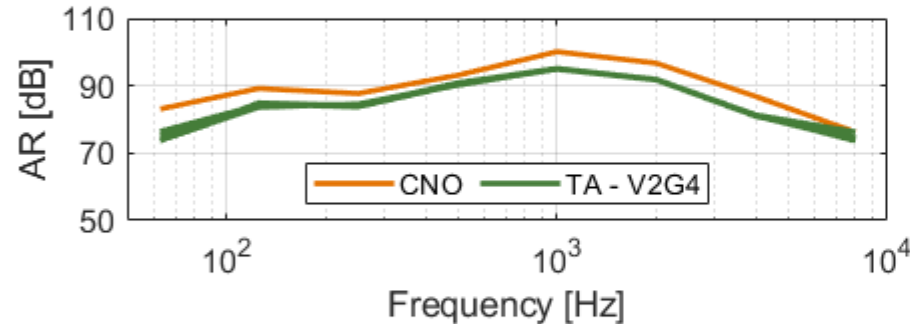
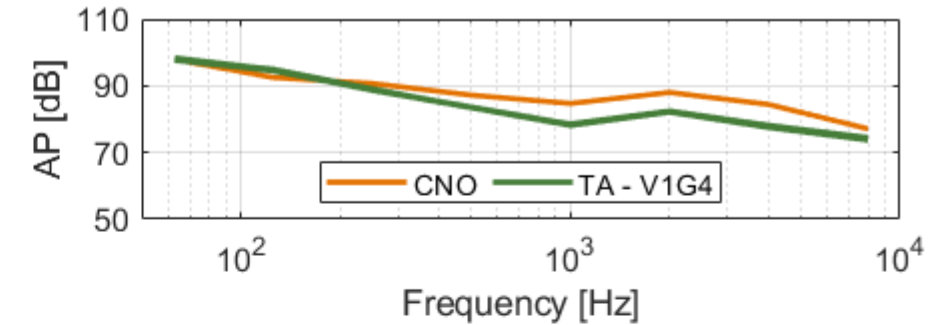
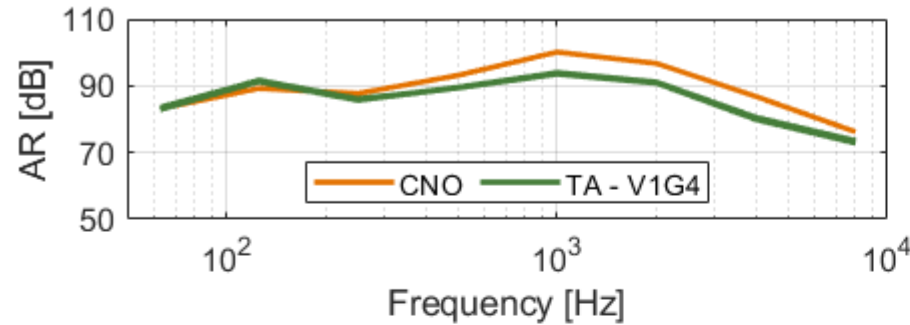

Possibilities for integrating sound emission changes

New coefficients from TA data – Procedure – Step 7



A-weighted coefficients

V1/V2: Vehicle 1/2

G4/G5: Gear 4/5

Note: various runs considered

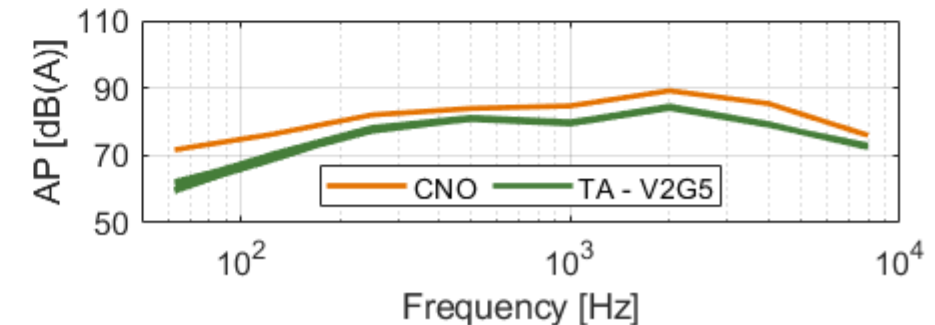
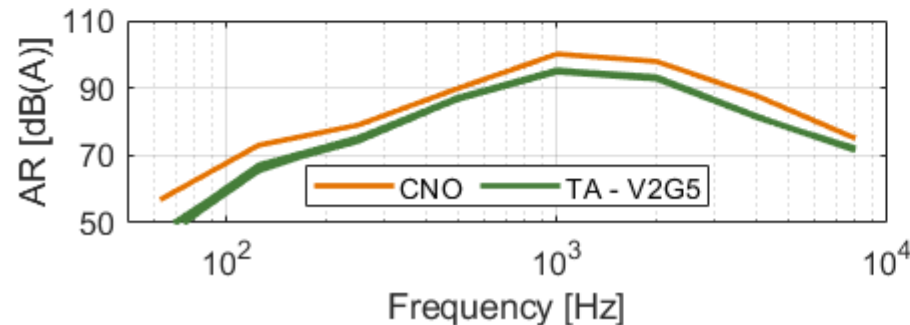
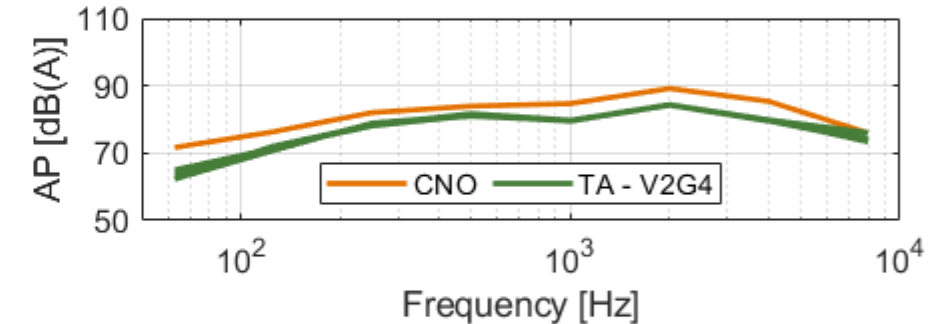
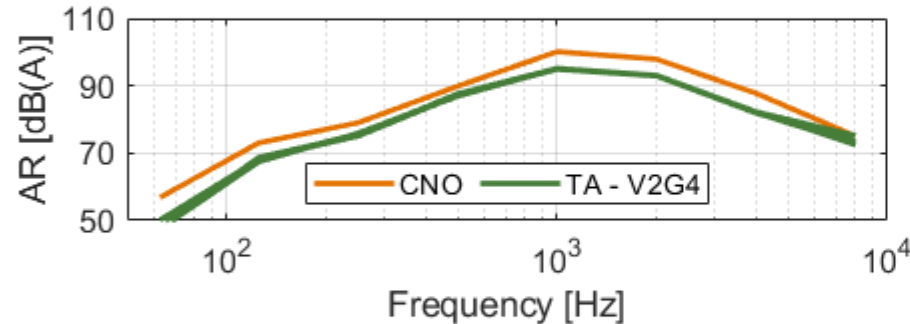
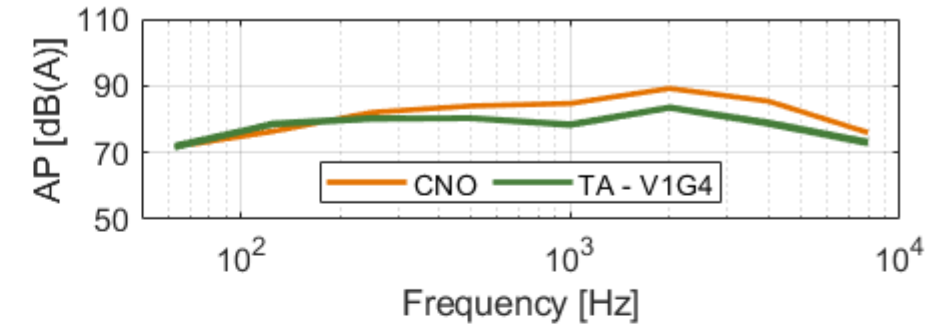
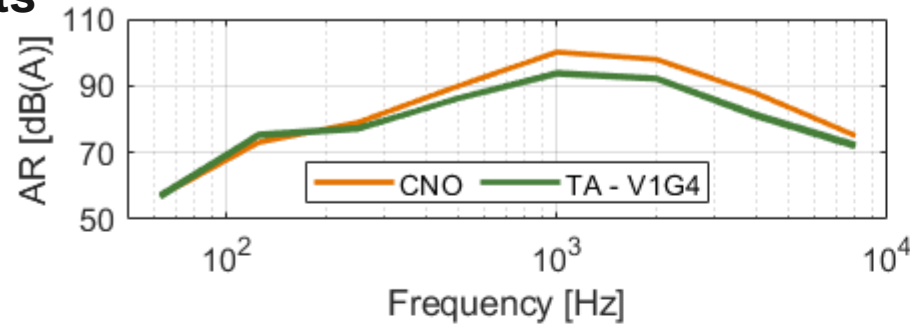

Possibilities for integrating sound emission changes

New coefficients from TA data – Procedure – Step 7



A-weighted coefficients

V1/V2: Vehicle 1/2

G4/G5: Gear 4/5

Note: various runs considered

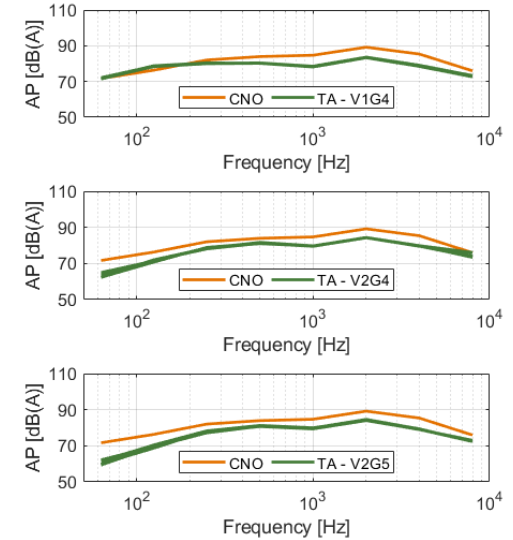
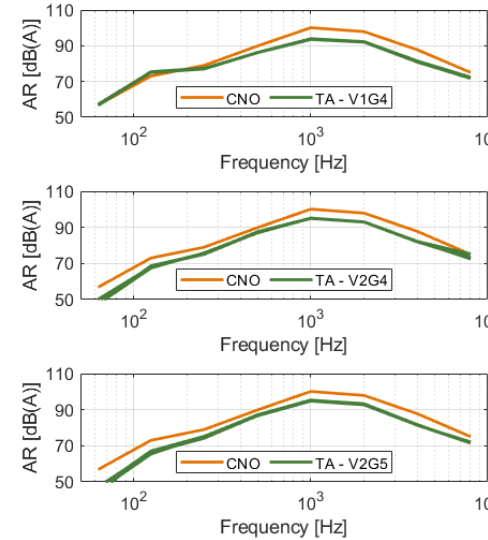

Overall levels [dB(A)]										
Vehicle & Gear	A_R			A_P			L_W			\emptyset
	CNO	TA	Δ	CNO	TA	Δ	CNO	TA	Δ	
V1G4	102.6	95.0	-7.5	93.0	85.7	-7.3	103.0	95.5	-7.5	-6.8
V2G4	102.6	96.2	-6.4	93.0	86.2	-6.7	103.0	96.6	-6.4	
V2G5	102.6	96.1	-6.5	93.0	86.0	-6.9	103.0	96.5	-6.5	

Possibilities for integrating sound emission changes

New coefficients from TA data – Procedure – Step 7



A-weighted coefficients & surface correction

V1/V2: Vehicle 1/2

G4/G5: Gear 4/5

Note: various runs considered

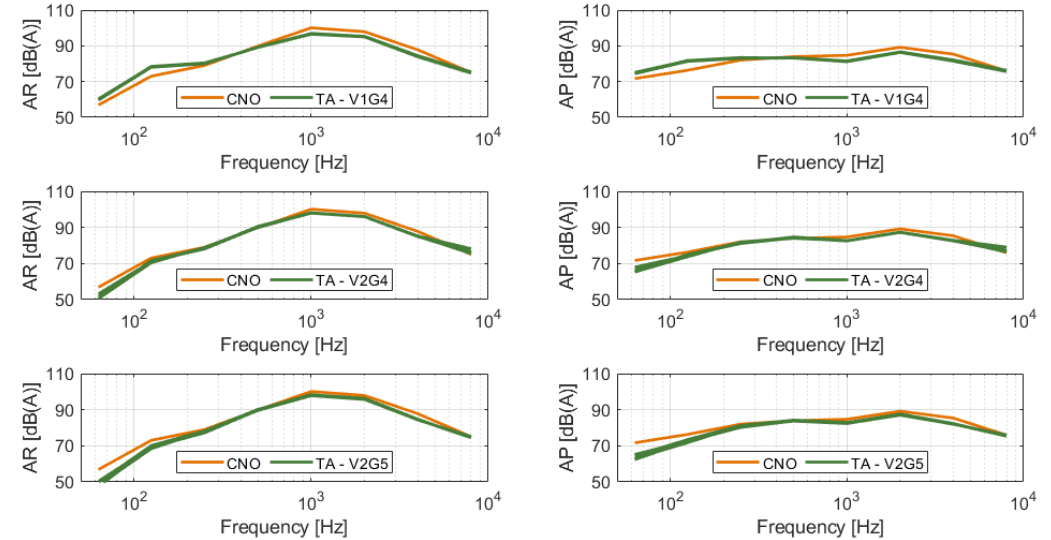

Overall levels [dB(A)] & exemplary road surface correction of +3dB										
Vehicle & Gear	A_R			A_P			L_W			\emptyset
	CNO	TA	Δ	CNO	TA	Δ	CNO	TA	Δ	
V1G4	102.6	98.0	-4.5	93.0	88.7	-4.3	103.0	98.5	-4.5	-3.8
V2G4	102.6	99.2	-3.4	93.0	89.2	-3.7	103.0	99.6	-3.4	
V2G5	102.6	99.1	-3.5	93.0	89.0	-3.9	103.0	99.5	-3.5	

Possibilities for integrating sound emission changes

New coefficients from TA data – Procedure – Step 7



A-weighted coefficients & surface correction

V1/V2: Vehicle 1/2

G4/G5: Gear 4/5

Note: various runs considered

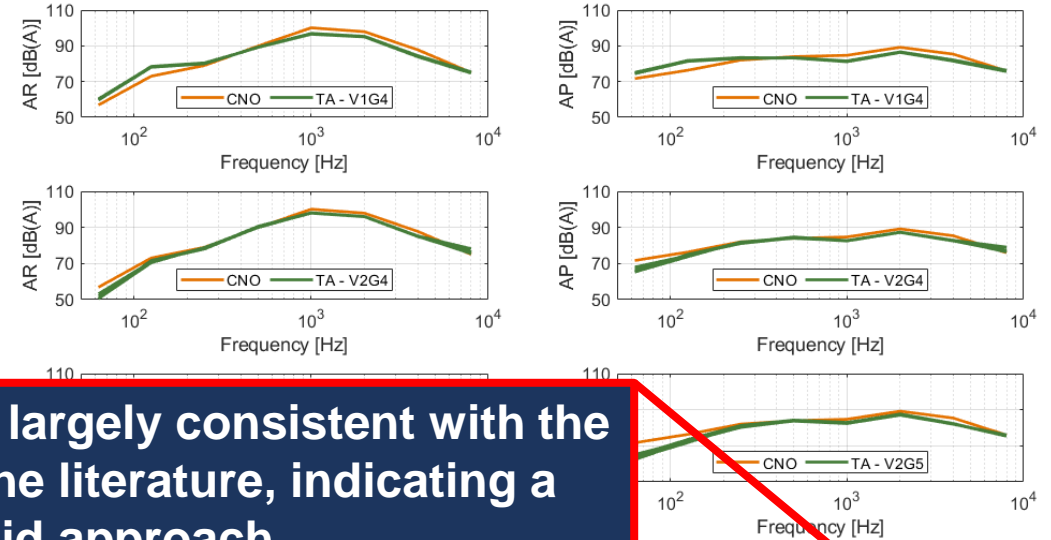

These results are largely consistent with the findings from the literature, indicating a valid approach

Overall levels [dB(A)] & exemplary road surface correction of +3dB										
Vehicle & Gear	A_R			A_P			L_W			\emptyset
	CNO	TA	Δ	CNO	TA	Δ	CNO	TA	Δ	
V1G4	102.6	98.0	-4.5	93.0	88.7	-4.3	103.0	98.5	-4.5	-3.8
V2G4	102.6	99.2	-3.4	93.0	89.2	-3.7	103.0	99.6	-3.4	
V2G5	102.6	99.1	-3.5	93.0	89.0	-3.9	103.0	99.5	-3.5	

Motivation

- » Aim: Update CNOSSOS coefficients using type approval measurements (TA)
- » Procedure:
 1. Estimate calculation procedure to get SEL from TA
 2. Comprehend the CNOSSOS transfer functions (TFs) from point source (vehicle) to receiver (microphone)
 3. Rebuilding the TFs
 4. Identification of different conditions for TA compared to SPB reg. the TFs
 5. Adaption of the TFs (according to findings in 4.)
 6. Identification of different conditions for TA compared to SPB reg. the correction factors in CNOSSOS
 7. Estimation of coefficients for new vehicles

Transfer functions from L_W to SEL

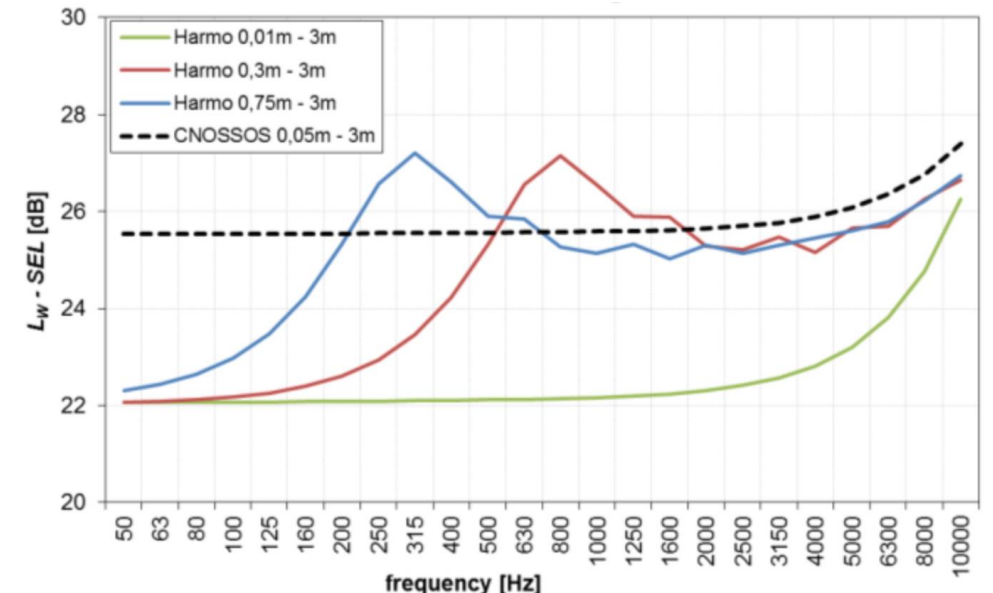

50 Hz	63 Hz	80 Hz	100 Hz	125 Hz	160 Hz	200 Hz	250 Hz	315 Hz	400 Hz	500 Hz	630 Hz
25.53	25.53	25.53	25.53	25.54	25.54	25.54	25.55	25.55	25.56	25.56	25.57
800 Hz	1 kHz	1.25 kHz	1.6 kHz	2 kHz	2.5 kHz	3.15 kHz	4 kHz	5 kHz	6.3 kHz	8 kHz	10 kHz
25.58	25.59	25.60	25.62	25.65	25.70	25.77	25.89	26.07	26.35	26.77	27.40

[BLO17] [PEE18]

- » **Project plan**
- » **Work Package 1 → Literature review**
 - » WP 1.1: Analysis of current source description models (END & CNOSSOS-EU)
 - » WP 1.2: Evaluation of noise mapping & management actions
- » **Work Package 2 → Elaboration of correction factors**
 - » WP 2.1: Analysis of existing source description methods
 - » WP 2.2: Determination of source description accuracy
 - » WP 2.3: Suitable adaptations of the source description
- » **Summary**
- » **Outlook**

- » **CNOSSOS-EU is a method for calculating ambient noise with the goal of strategic noise mapping and was first introduced in 2015**
 - » The noise source *vehicle* is described via **frequency-dependent sound power coefficients for rolling and propulsion noise** and the **vehicle speed**
 - » **Basis of the sound power coefficients are comprehensive measurement campaigns up to 2006**
- » **CNOSSOS-EU sound power coefficients were updated in 2021** to correct a previously made assumption
- » Based on existing data, it has been shown that **vehicle noise has decreased** significantly, which is **not reflected in current CNOSSOS-EU sound power coefficients**
- » **Deriving new coefficients for modern M1-vehicles would require an extensive SPB measurement campaign**
- » A **procedure** has been developed and verified for calculating **new CNOSSOS-EU sound power coefficients from type approval data**

- » **Project plan**
- » **Work Package 1 → Literature review**
 - » WP 1.1: Analysis of current source description models (END & CNOSSOS-EU)
 - » WP 1.2: Evaluation of noise mapping & management actions
- » **Work Package 2 → Elaboration of correction factors**
 - » WP 2.1: Analysis of existing source description methods
 - » WP 2.2: Determination of source description accuracy
 - » WP 2.3: Suitable adaptations of the source description
- » **Summary**
- » **Outlook**

Recommended future working points for the derivation of new coefficients:

- » **Investigation** of many and especially **different vehicles** as well as **different vehicle categories**

- » **Integration** of a **precise surface correction**

- » Further investigation on **technical changes in vehicle fleets** over time
 - » Rolling vs. propulsion noise distribution
 - » Frequency distribution

- » Derivation of **national fleet coefficients**

- » If required: **Inclusion of accelerated driving + investigation on acceleration correction**

Reference	Description
[ABB02]	Abbott, P.G.; Nelson, P.M.; 2002 Converting the UK traffic noise index L_A10,18h to EU noise indices for noise mapping
[AL23]	https://c8.alamy.com/ (access: 25.04.2023 1pm)
[ASC22]	E. Ascari; et al.; 2022 Statistical Pass-By for Unattended Road Traffic Noise Measurement in an Urban Environment
[ATE22]	ATEEL; 2022 Study on future sound limit values for type approval for vehicles of category M & N
[BC17]	Noise pollution limits for Spain (https://coneixement-eu.bcn.cat/) (access: 02.05.2023 1pm)
[BEC01]	Beckenbauer, T.; 2001; FE-Nr. 03.293/1995/MRB: Einfluss der Fahrbahntextur auf das Reifen-Fahrbahn-Geräusch
[BEU06]	M. Beuving; B. Hemsworth; 2006 IMAGINE – Final Synthesis Report (IMA10TR-06116-AEATNL10)
[BLO17]	G. Van Blokland; B. Peeters; 2017 Interface between the CNOSSOS-EU road traffic noise emission model and the propagation model Report M+P.RIVM.17.03.1
[BU17]	https://www.berlin.de (access: 13.04.2023 9am)
[BU22]	https://www.hamburg.de/data/Iden-strasse-2022.pdf (access: 13.04.2023 11am)
[BR17]	https://carto.bruitparif.fr/ (access: 18.04.2023 9am)

Reference	Description
[BR22]	Regulations for noise limits on France roads (https://www.bruitparif.fr/la-reglementation4/) (access: 02.05.2023 1pm)
[BRU17]	https://carto.bruitparif.fr/ (access: 18.04.2023 9am)
[BRU19]	Noise mapping review France 2017 (https://www.bruitparif.fr) (access: 25.04.2023 1pm)
[BRU22]	Regulations for noise limits on French roads (https://www.bruitparif.fr/la-reglementation4/) (access: 02.05.2023 1pm)
[CI22]	www.citypopulation.de (access: 09.04.2023 1pm)
[DEL19]	G. De León; F. Fidecaro; M. Cerchiai; M. Reggiani; E. Ascari; G. Licitra; 2019 Implementation of CNOSSOS-EU method for road noise in Italy Proceedings of the 23 rd International Congress of Acoustics
[DER11]	F. De Roo, M.G. Dittrich, P.J.G. van Beek, C. Bosschaart, G.B. Derksen, M. de Kievit; 2011 VENOLIVA – Vehicle Noise Limit Values – Comparison of two noise emission test method Final Report MON-RPT-2010-02103
[DEV]	Development and implementation Harmonised noise assessment methods
[DIT15]	M. Dittrich; J. Sliggers; 2015 A Policy Indicator for Road Traffic Noise Emission Informal document GRB-62-14
[ECO12]	Ecotiere, D.; Foy, C.; Dutilleux, G.; 2012 Comparison of engineering models of outdoor sound propagation: NMPB2008 and Harmonoise-Imagine

Reference	Description
[EE20]	Guideline to create noise action plan (European environmental agency) (https://www.eionet.europa.eu/) (access: 02.05.2023 2pm)
[EE22]	https://www.eea.europa.eu/ (access 18.04.2023 1am)
[EE23]	https://environment.ec.europa.eu (access: 13.04.2023 1pm)
[EU22]	Population density by metropolitan region [MET_D3DENS] (https://ec.europa.eu/Eurostat/) (access 18.04.2023 1pm)
[EU23]	Population by age groups and NUTS-3-Region [CENS_21AGR3] (https://ec.europa.eu/eurostat/) (access 18.04.2023 1am)
[EUR02]	The European Parliament; 2002 Directive 2002/49/EC relating to the assessment and management of environmental noise
[EUR11]	2011 Common Noise Assessment Methods in Europe (CNOSSOS-EU)
[EUR15]	The European Commission; 2015 COMMISSION DIRECTIVE (EU) 2015/996 of 19 May; establishing common noise assessment methods according to Directive 2002/49/EC of the European Parliament and of the Council
[EUR21]	The European Commission; 2021 COMMISSION DELEGATED DIRECTIVE (EU) 2021/1226 of 21 December; amending, for the purposes of adapting to scientific and technical progress, Annex II to Directive 2002/49/EC of the European Parliament and of the Council as regards common noise assessment Methods
[EP09]	Guidance Note for Noise Action Planning (https://www.epa.ie) (access: 03.05.2023 11am)

Reference	Description
[EP18]	https://www.epa.ie/our-services (access: 03.05.2023 10am)
[EP20]	https://www.epa.ie/ (access: 02.05.2023 11am)
[FER07]	FEHRL; 2007 Volume 1: Final Report Report SI2.408210
[FG15]	Noise mapping review France 2007 – 2012 (https://www.bruitparif.fr/) (access: 25.04.2023 1pm)
[FG19]	Noise mapping review France 2017 (https://www.bruitparif.fr) (access: 25.04.2023 1pm)
[IMA07a]	Peeters, B.; Blokland, G.;2007 Deliverable 11 of the IMAGINE project: The Noise Emission Model For European Road Traffic
[IMA07b]	IMAGINE Work Package 5, G.;2007 IMA55SS-061117-MP10: Model coefficients complimentary to Deliverable D11
[IN22a]	www.ine.es (access: 09.04.2023 1pm)
[IN22b]	www.insee.fr (access: 09.04.2023 1pm)
[IS22]	www.istat.it (access: 09.04.2023 1pm)
[ISO16]	ISO 1996-1; 2016 Acoustics – Description, measurement and assessment of environmental noise; Part 1: Basic quantities and assessment procedures

Reference	Description
[ISO21]	ISO 10844; 2021 Acoustics – Specification of test tracks for measuring sound emitted by road vehicles and their tires
[ISO22a]	ISO 362-1; 2022 Acoustics — Engineering method for measurement of noise emitted by accelerating road vehicles — Part 1: M and N categories
[ISO22b]	ISO 11819-1; 2022 Acoustics – Measurement of the influence of road surfaces on traffic noise - Part 1: Statistical Pass-By method
[ISO93]	ISO 9613-1; 1993 Acoustics – Attenuation of sound during propagation outdoors – Part 1: Calculation of the absorption of sound by the atmosphere
[JON00]	Jonasson, H.; 2000 Measurement and Modelling of Noise Emission of Road Vehicles for Use in Prediction Models
[JON04]	Jonasson, H.; et al.; 2004 Work Package 1.1: Source modelling of road vehicles (Deliverable 9 of the Harmonoise project)
[JON06]	Jonasson, H.; 2000 Acoustic Source Modelling of Nordic Road Vehicles
[KAN21]	Kantor, E ; et al. 2021 Assessment of potential health benefits of noise abatement measures in the EU

Reference	Description
[KEU05]	Christina Keulemans; 2005 IMAGINE - Sound power measurements on heavy vehicles to study propulsion noise (IMA05TR-050618-Volvo01)
[KEP12]	S. Kephelopoulos; M. Paviotti; F. Anfosso-Lédée; 2012 Common Noise Assessment Methods in Europe (CNOSSOS-EU) EUR 25379 EN. Luxembourg (Luxembourg): Publications Office of the European Union, JRC72550
[KEP14]	S. Kephelopoulos; M. Paviotti; F. Anfosso-Lédée; D. Van Maercke, S. Shilton; N. Jones; 2012 Advances in the development of common noise assessment methods in Europe: The CNOSSOS-EU framework for strategic environmental noise mapping Science of the Total Environment 482-483 (2014), 400-410
[KOK18]	J. Kokkonen; 2018 CNOSSOS-EU noise model implementation in Finland and experience of it in 3rd END round
[KOK19a]	A. Kok; A. van Beek; 2019 RIVM letter report 2019-0023: Amendments for CNOSSOS-EU (incl. erratum)
[KOK19b]	A. Kok; 2019 Refining the CNOSSOS-EU calculation method für environmental noise
[KS22]	www.ksh.hu (access: 09.04.2023 1pm)
[MOR03]	P.A. Morgan; P.M. Nelson, H. Steven; 2003 Integrated assessment of noise reduction measures in the road transport sector Report PR SE/652/03

Reference	Description
[MOR06]	Morgan, P.; 2006 FEHRL Report/Guidance Manual on “SILVIA – Sustainable Road Surface for Traffic Noise Control”
[NMPB08]	Dutilleux, G.; et al.; 2009 Road noise prediction - 2 -Noise propagation computation method including meteorological effects (NMPB 2008)
[PAR22]	https://www.paris.fr/ (access: 21.04.2023 9am)
[PEE17]	B. Peeters; 2017 CNOSSOS-NL: Issues for national implementation of the EU road noise emission model
[PEE18]	Peeter, B.; van Bolkland, G.; 2018 Correcting the CNOSSOS-EU road noise emission values
[PF22]	https://www.paris.fr/ (access: 21.04.2023 9am)
[RMG12]	Minister van Infrastructuur en Milieu; 2012 Reken- en meetvoorschrift geluid, Nr. IENM/BSK-2012/37333
[SAL11]	Salomons, E.; Van Maercke, D; Defrance, J.; 2011 The Harmonoise Sound Propagation Model
[SHI15]	S.J. Shilton; et al.; 2015 Conversion of existing road source data to use CNOSSOS-EU
[ST22a]	www.statistik-berlin-brandenburg.de (access: 09.04.2023 1pm)
[ST22b]	www.statistik.at (access: 09.04.2023 1pm)

Reference	Description
[ST22c]	www.statistik-nord.de (access: 09.04.2023 1pm)
[ST22d]	www.stat.gov.pl (access: 09.04.2023 1pm)
[STA22]	Standards and Research Section, Transport Infrastructure Ireland; 2022 Common Noise Assessment Methods in Europe (CNOSSOS-EU) Interim Road Surface Correction Factors for National Roads in Ireland
[STE05]	H. Steven; 2005 Investigations on Noise Emission of Motor Vehicles in Road Traffic Final Report of Research Project 200 54 135, RW TÜV Fahrzeug GmbH
[TNO00]	J. D. van der Toorn; W.J.A. van Vliet; 2000 TNO report HAG-RPT-000048 Emissiekentallen motorvoertuigen 2000, gebaseerd op metingen uit 1996 en 1999 (Emission characteristics of motor vehicles 2000, based on measurements performed in 1996 and 1999)
[TP23]	Transparency portal of the Madrid City Council
[TPM23]	Transparency portal of the Madrid City Council
[UB22]	https://www.umweltbundesamt.de/themen/laerm (access: 18.04.2023 1am)
[US06]	https://www.umwelt.sachsen.de (access: 13.04.2023 10am)
[VAN12]	Van Maercke, D.; Jean, P.; 2012 A general approach for extending the range of application of standard noise mapping methods

Reference	Description
[WAT04]	Watts, G.; et al; 2004 Effects of speed distributions on the Harmonoise model prediction
[WH18]	Environmental noise guidelines for the European region (WHO) (https://www.who.int/) (access: 18:04.2023 10am)
[ZHA14]	Zhang Xuetao; 2014 Three Typical Noise Assessment Methods in EU

CONTACT

Institute for Automotive Engineering (ika),
RWTH Aachen University
On behalf of

fka GmbH
Steinbachstr. 7
52074 Aachen
Germany

Caroline Schliephake, M.Sc.
phone +49 241 80 25660
e-mail carolin.schliephake@ika.rwth-aachen.de

Dr.-Ing. Daniel Wegener
phone +49 241 8861187
e-mail daniel.wegener@fka.de

fka
CREATING IDEAS &
DRIVING INNOVATIONS